

 **Husqvarna**

Workshop manual chain saw model 181



Contents

1.	Technical Data	3
2.	Service Data	5
3.	Special Tools	7
4.	Fuel system	11
5.	Electric system	17
6.	Lubricating system	19
7.	Cylinder, Piston	23
8.	Crankcase, Crankshaft	27
9.	Starter	33
10.	Centrifugal Clutch	35
11.	Safety Equipment	37

Displacement	80.7 cm ³ (4.9 cu in)
Bore	52.0 mm (2.05")
Stroke	38.0 mm (1.5")
Power output	4.0 kW (5.5 hp) at 140 r/s (8.400 r/min)
Ignition system	Make SEM type AM 7
Ignition advance	25° before t.d.c. at 142 r/s (8.500 r/min)
Air gap	0.30 mm (0.012")
Spark plug type	Champion RCJ 7Y
Electrode gap	0.5 mm (0.020")
Handle heating (181 SG)	56 watts at 120 r/s (7.200 r/min)

Carburettor
 Diaphragm carburettor make Tillotson type HS 216
 Basic setting:
 H = 1.0
 L = 1.0

Fuel tank volume
 0.85 litres (0.22 US gallon, 0.19 Imp gallon).
 Fuel mixture 4% (1:25)
 With Husqvarna Twostroke Oil 2% (1:50)

Oil tank volume
 0.50 litres (0.13 US gallon, 0.11 Imp gallon)

Chain lubrication
 Automatic. No supply during idling. Adjustable for 4 different delivery rates.
 Recommended positions:
 Bar 18": Pos. 2
 Bar 20" and more: Pos. 3-4

Clutch drum/sprocket
 Standard 7 teeth. Optional 8 teeth. 3/8" pitch.

Weights	Mod. 181 SE	Mod. 181 SG	
	Weight sawbody incl. chain brake (empty)	6.8 kg 15.0 lb	7.0 kg 15.4 lb
	Weight sawbody (empty) incl. chain brake and 18" bar and chain	8.2 kg 18.1 lb	8.4 kg 18.5 lb

Classification table	Cylinder class	Piston class
	A	A
	B	B
	C	C

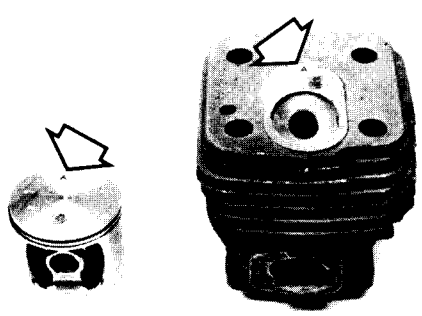

PLEASE NOTE!
 As "A" denotes smallest cylinder diameter and "C" the largest, piston grades should be matched or one grade smaller. Eg it is not permissible to use a grade B piston in a grade A cylinder.

Crankcase Assy

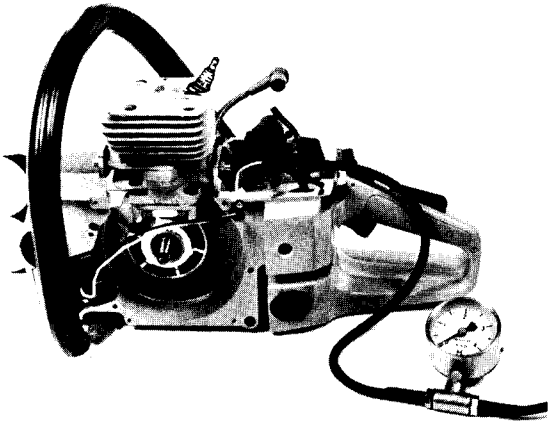

Vacuum: 0.04 MPa (0.4 kp/cm², 5.7 psi)
Max. leakage: 0.01 MPa/1 min (0.1 kp/cm², 1.4 psi per min)

Tools: 50 25 037-01 Vacuum gauge
 50 25 047-01 Cover plate, inlet port
 50 25 081-01 Cover plate, exhaust port

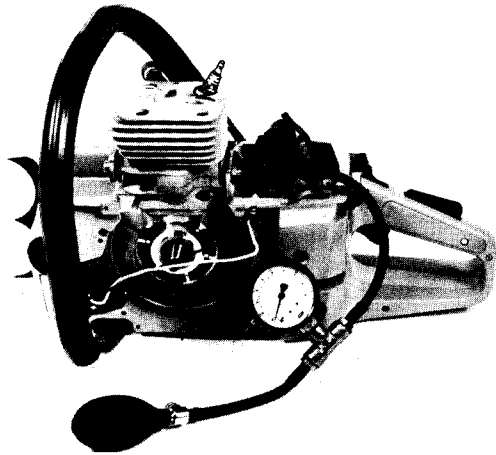

Pressure: 0.08 MPa (0.8 kp/cm², 11.4 psi)
Max. leakage: 0.02 MPa/30 sec (0.2 kp/cm², 2.8 psi per 30 sec)

Tools: 50 25 038-01 Pressure gauge
 50 25 047-01 Cover plate, inlet port
 50 25 081-01 Cover plate, exhaust port

Fuel tank

Pressure: 0.05 MPa (0.5 kp/cm², 7.1 psi)
Leakage: No leakage permitted

Tool: 50 25 038-01 Pressure gauge

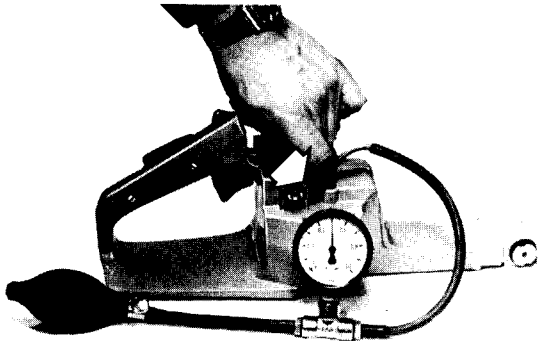

Starter

Make sure that it is possible to turn the pulley at least about 1/4 turn further when the cord is pulled out completely.

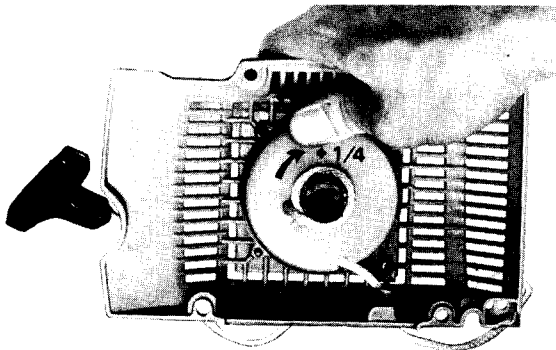

Carburettor

Pressure: 0.03 MPa (0.3 kp/cm², 4.3 psi)
Leakage: No leakage permitted

Tool: 50 25 038-01 Pressure gauge

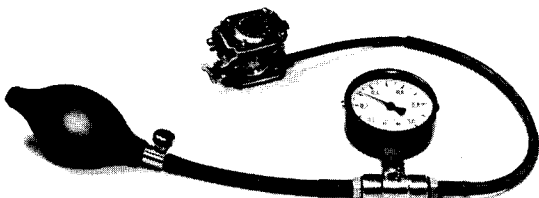

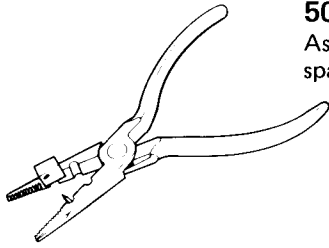

50 25 006-01
Assembling pliers,
spark plug protector

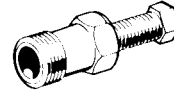

50 25 026-01
Puller compl. with screw

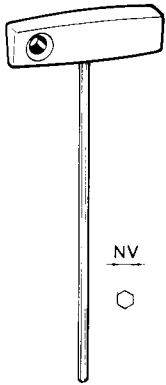

50 25 018-01 NV 4 mm
50 25 019-01 NV 3 mm
50 25 057-01 NV 3/16"
Allen key

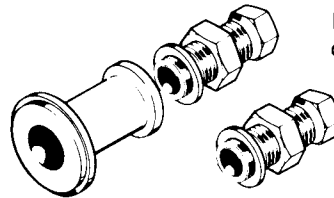

50 25 030-08
Fitting tool compl. for
crankshaft and sealing ring

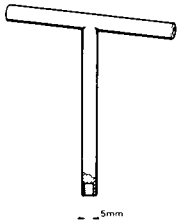

50 25 020-01 (M5)
Stud fitting tool

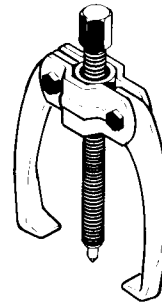

50 49 090-01
Ball bearing puller compl.

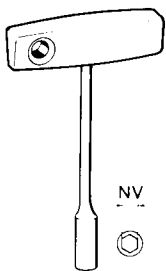

50 25 022-01 NV 8 mm
50 25 023-01 NV 10 mm
Socket spanner

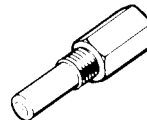

50 25 033-01
Piston stop



50 25 146-02
Revolution counter

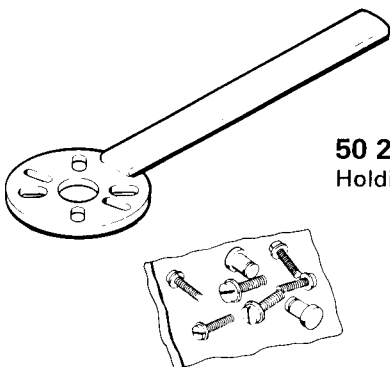

50 25 149-01
Holding bar compl.

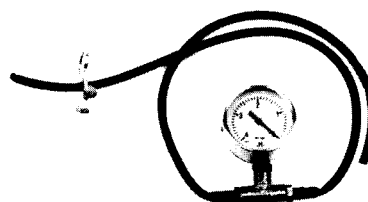

50 25 037-01
Vacuum gauge compl.

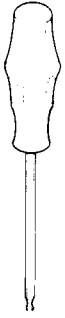

50 25 086-01 NV 3 mm
50 25 087-01 NV 4 mm
 Allen screwdriver with ball

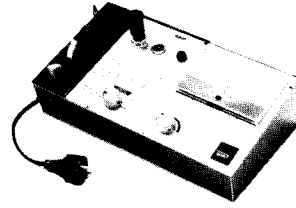

50 25 124-01
 SEM electric system tester



50 25 091-01
 Retouch paint, orange 1/8 l



50 25 134-02
 Air gap tool

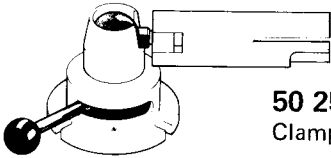

50 25 102-01
 Clamping device

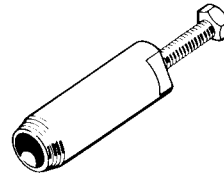

50 25 101-01
 Extractor sealing ring

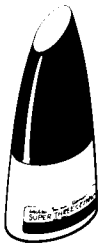

50 25 106-01
 Glue, adhesive

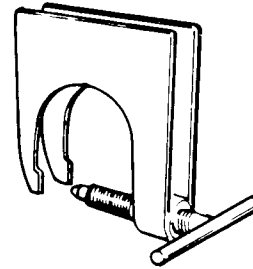

50 25 161-01
 Puller for engineblock

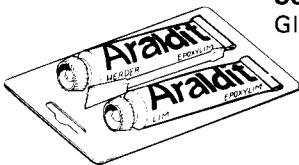

50 25 107-01
 Glue, epoxy

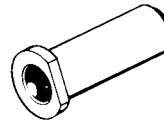

50 25 082-01
 Fitting drift, sealing ring



50 25 108-01
 Loctite AA (normal locking power)
50 25 109-01
 Loctite AAV (strong locking power)

2. Service Data

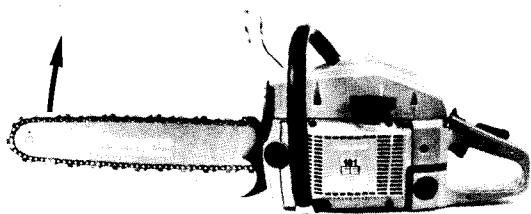

Chain brake

When used with a 18" guide bar the Swed-o-Matic should release at a load on the bar tip of 12–17 kp (26–37 lb).

Replace the brake band as soon as wear has reduced its original thickness by more than 25%, i.e. at least 0,75 mm (0.03") must be left of the original band thickness.

Fuel and oil

The twostroke engine is lubricated by oil mixed with petrol in various proportions depending on the type of oil used:

Ordinary twostroke oil 1:25 (4% oil)

Husqvarna Twostroke oil 1:50 (2% oil)

See also the mixing table below:



Mixing table

Mixing table		2 %			4 %		
Litres of oil	Pints of oil	Litres of petrol	Petrol in Imp gallon	Petrol in US gallon	Litres of petrol	Petrol in Imp gallon	Petrol in US gallon
0.2	0.35	10	2.2	2.6	5	1.1	1.3
0.4	0.70	20	4.4	5.2	10	2.2	2.6
1.0	1.76	50	11.0	13.2	25	5.5	6.6

Removal of carburettor

Remove the air filter and the fuel hose.
 Remove the throttle push rod from the plastic lever with a pair of flat hose pliers.
 Remove the stop switch in order to get at the left screw that retains the carburettor.
 Push out the choke control from the lever on the carburettor.
 Loosen the screw that connects the air filter elbow to the crankcase.
 Loosen the socket head screws that retain the carburettor (use the Allen key No. 50 25 018-01) and lift the carburettor off together with the air filter elbow and the screws.
 Clean the carburettor on the outside.

Remove the metering diaphragm cover and the metering diaphragm.
 Note that the centre pin of the diaphragm enters the forked end of the lever of the needle valve.
 Connect the pressure gauge 50 25 038-01 to the fuel inlet of the carburettor and pump until a pressure of 0.03 MPa (0.3 kp/cm²) is reached.
 Check for any leakage at the needle valve or at the gasket on the pump side.
 The easiest way of locating leakages is to pour some petrol where you suspect the leakages to be.

Loosen the screw that retains the bearing shaft of the lever and remove lever, shaft, spring and needle valve.

Drill a small hole in the welch plugs (approx. Ø 2 mm) and prise away the plugs by means of a pointed tool.

NOTE! Drill with care in order not to damage the carburettor housing.

Unscrew the two adjusting needles.
 Remove the cover above the pump diaphragm and remove diaphragm and gasket.

Lift off the fuel screen carefully by means of a pointed tool.

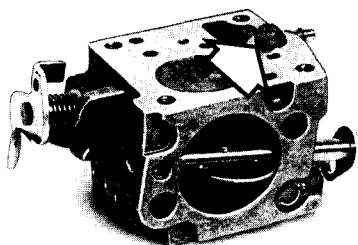
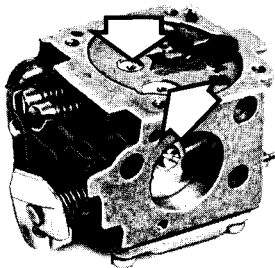
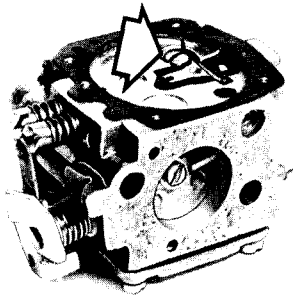
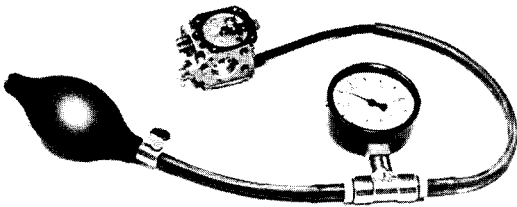
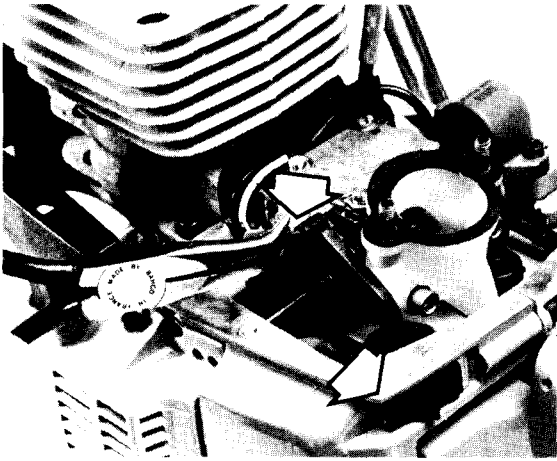

3. Special Tools

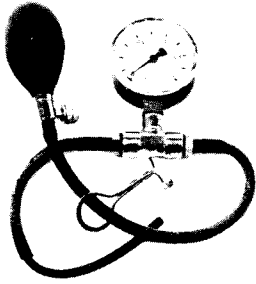

50 25 038-01
Pressure gauge compl.

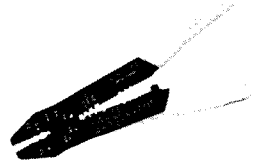

50 25 051-01
Cable clip pliers

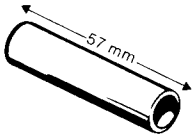

50 25 046-01
Distance sleeve (57 mm)

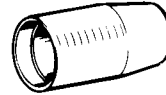

50 25 052-01
Fitting sleeve for
sealing ring

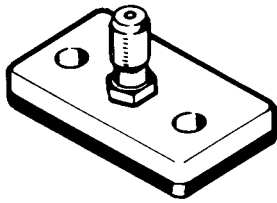

50 25 047-01
Cover plate, inlet port

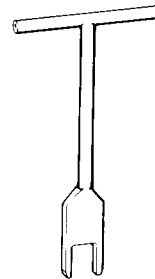

50 25 066-02 NV 22 mm
U-spanner for vibration
damper

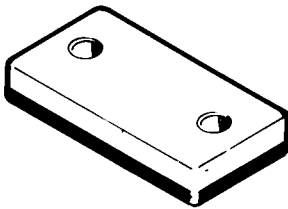

50 25 081-01
Cover plate, exhaust port

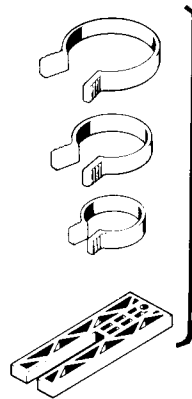

50 25 070-01
Piston mounting set
compl.

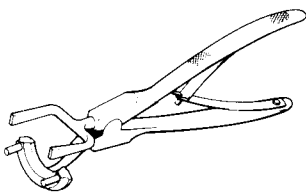

50 25 049-01
Assembling pliers,
centrifugal clutch

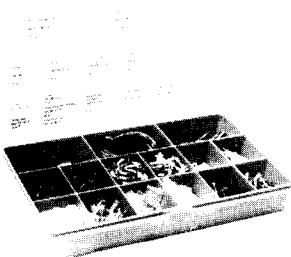

50 25 050-01
Repair kit for elec-
tric cables

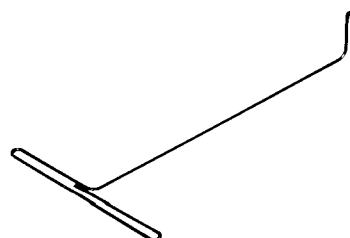

50 25 083-01
Hook for fuel filter

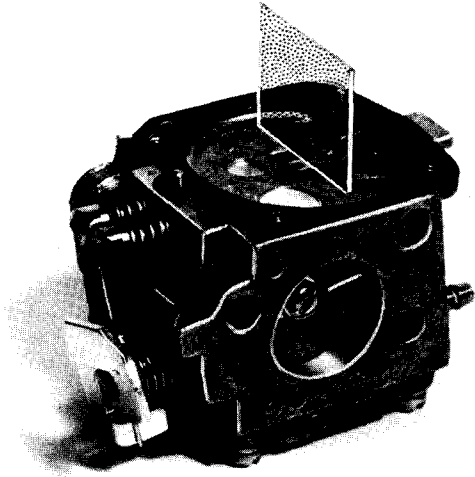

When properly adjusted the lever of the needle valve shall be on a level with the carburettor housing surrounding it.

If the lever is located too high, the carburettor will be very sensitive as regards the adjustment of the adjusting needles.

A too low lever induces bad acceleration qualities.

Check that the lever can move freely.

Make a pressure test of the carburettor. Proceed as mentioned above. Then mount gasket, metering diaphragm and cover.

NOTE!

Care should be taken to ensure that the centre pin of the diaphragm enters the fork in the lever!

Install the adjusting needles and screw them out to the following basic position: H = 1.0 turn open. L = 1.0 turn open.

Adjustment of carburettor

A. Basic setting

Before adjusting the carburettor, proceed as follows:

- Clean the air filter or, if necessary, replace it with a new one.
- Check the spark plug and its electrodes.
- Check that the fuel filter is not clogged.

Examine the fuel filter as follows:

Loosen the fuel hose from the carburettor and lay the chain saw on the clutch side. Open the tank cap. If there is enough fuel in the tank, some of it now ought to run out of the hose.

After having made the abovementioned checks you make a basic adjustment of the carburettor needles, i.e. H = 1 turn open and L = 1 turn open.

Start the chain saw and warm it up by applying full throttle and letting it cut into a log.

A constant speed for 10–20 sec indicates not only a good high speed function of the carburettor but also a good condition overall.

Should there be a sudden lean supply to the engine after approx. 10–20 sec full throttle running (big speed increase), this would indicate some fault in the fuel system.

The trouble may be caused by:

- Leakage in the pumping section of the carburettor.
- Crack in the insulating piece.
- Loose carburettor bolts.
- Incorrectly assembled or leaking gaskets.
- Tank breather valve inoperative.
- Fuel filter clogged.

NOTE!

Too lean adjustment of the carburettor would cause a considerable loss of power. Adjust the carburettor in order to obtain maximum power and not maximum speed.

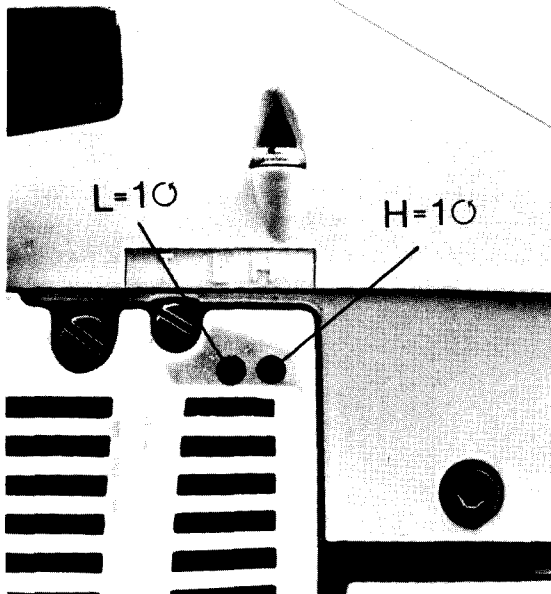
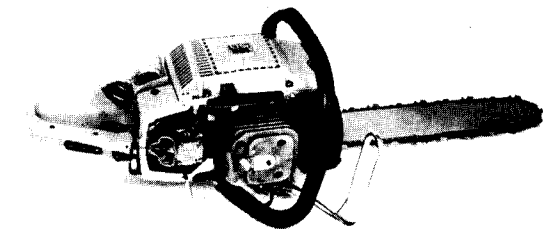

4. Fuel system

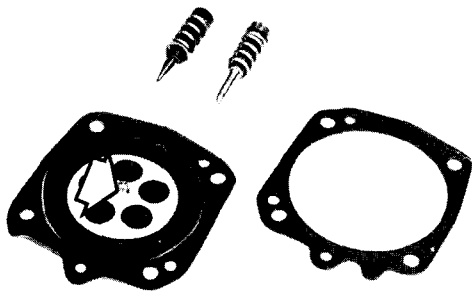

Carburettor check

A. Pumping section

Clean the fuel screen and -lines with compressed air. Check the gasket and the pump diaphragm for damage or wear.

B. Metering section

Check that the adjusting needles are straight and that their tapered ends are not damaged.

Check the gasket and the metering diaphragm for damage or wear. Check with particular care the wear on the centre pin of the diaphragm.

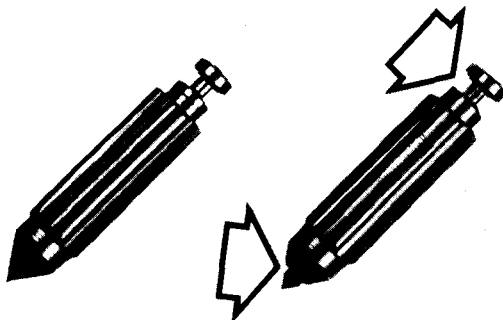

Check that the needle valve is not worn, neither on its seat, nor in the groove for the lever.

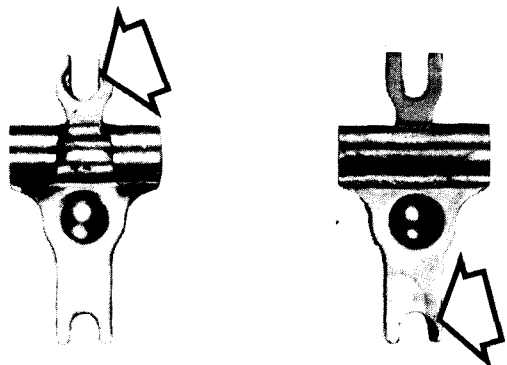

Check that the needle valve lever is not worn, neither at the connection to the needle valve nor the metering diaphragm.

Check that the filter screen near the main jet is not dirty or damaged.

C. Mixing section

Clean all fuel lines and jets with compressed air.

Replace damaged or worn parts with new ones.

Assembly

A. Pumping section

Locate the fuel screen carefully in its seating.

Locate the pump diaphragm next to the carburettor housing and then add gasket and cover.

Tighten the four screws of the cover diagonally and evenly.

B. Metering section

Fit new welch plugs. Install them with a suitable drift:

for the big plug: drift \varnothing 8 mm

for the small plug: drift \varnothing 4 mm

NOTE!

Do not press in the plugs so that they bulge inwards!

Mount needle valve, lever, spring and shaft.

Locate the spring properly!

TIP

The carburettor spare part kit has got No. 50 15 467-01.

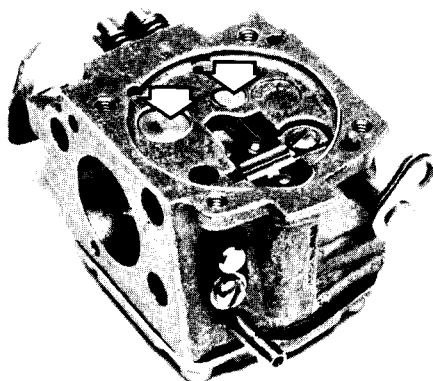

Trouble shooting guide

	Dirt in the fuel lines	Weak plugs loose	Adjusting needles (leakage at intermediate piece, gasket)	Needle seats damaged	Dirt in the screen	Worn details in metering section (needle valve)	Lever too high	Fuel filter clogged	Hole in fuel hose	Faulty tank breather	Leakage in pumping section	Fuel screen of pumping section clogged	Air filter clogged
Irregular idling speed								X	X				
Engine stops when accelerated (choke required)	X		X				X			X	X		
"Leaning out"			X							X	X	X	X
No fuel supply			X							X			
Difficult adjustment		X		X	X								
Too "rich" supply							X						X
No idling speed		X											
Extreme needle position	X	X					X						X

4. Fuel system

B. Adjustment of L-needle

Adjust the idling speed by means of the throttle adjusting screw T. Try to reach a position where the chain is just beginning to rotate, that is at a comparatively high idling speed.

Put your right hand on the front handle and make a fine adjustment of the L-needle with your left hand.

Fine adjustment is made as follows:

1. Screw in the L-needle slowly and the speed will increase. Screw in the needle a little further and the speed will slow down again as the fuel supply becomes too "lean". Notice the position of the needle at the highest speed.
2. Open the L-needle again and notice the highest position. Note that the speed slows down at "richer" supply.
3. Adjust the L-needle to the highest speed position. Then open it equivalent to 10 min on a clock-face to obtain a somewhat "richer" supply to aid acceleration.
4. By means of the T-needle, adjust the idling speed to 2.300 – 2.500 r/min, ensuring that the chain does not rotate when engine is idling.
5. Give full throttle a couple of times to check that the engine "responds". If not, open the L-needle by abt 3 min. Check again.

C. Adjustment of H-needle

Adjust the high speed needle (H) as follows:

Apply full throttle by keeping a *constant* grasp of the throttle trigger. At correct adjustment of the H-needle the engine should be fourstroking.

Screw in the H-needle slowly until there is no more fourstroking (position A). Then screw the needle out equivalent to 10 min on a clock-face.

Check by means of eg revolution counter No. 50 25 146-02 that the high idle speed does not exceed 12.500 r/min.

Now the carburettor adjustment is completed and you may release your hold of the throttle trigger.

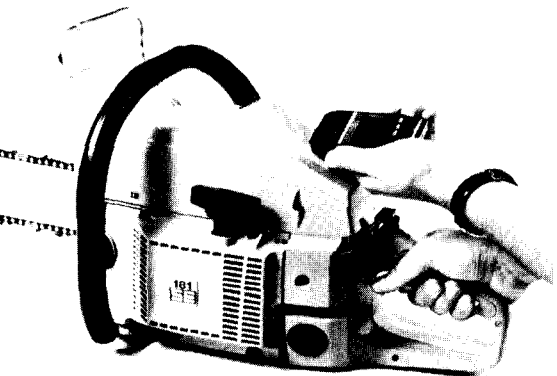
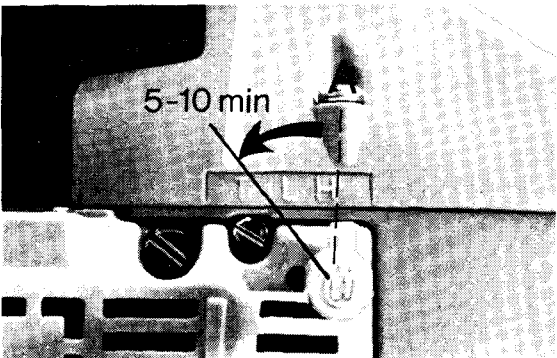
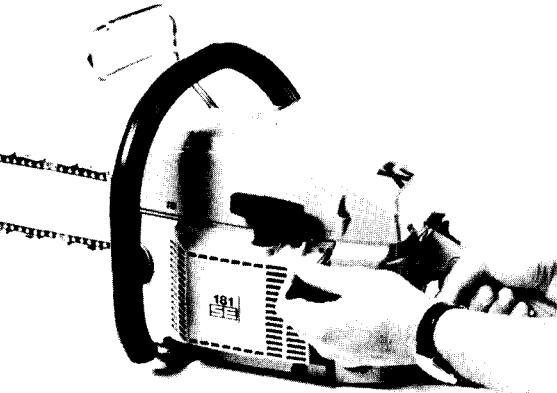
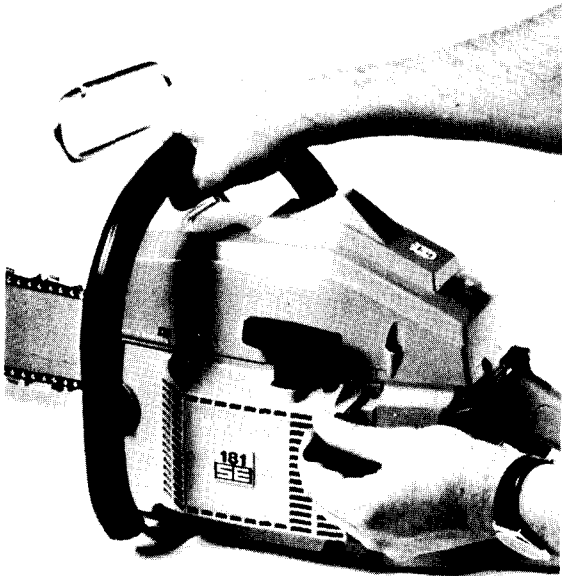



A. Ignition system, trouble shooting

In all ignition testing the plug must be firmly earthed against the cylinder in order to prevent damage to the system.

- A 1. Remove the spark plug. Connect the ignition cable and "earth" the plug against the cylinder. Check for a spark between the electrodes when you rotate the engine by pulling smartly on the starting handle. The stop switch should be in position 1.
- A 2. If no spark occurs, try a new plug. If still no spark, check the connection between ignition cable and spark plug protector.
- A 3. If still no ignition spark between the electrodes, disconnect the short circuiting cable from the switch. Check for a spark. In this case, the stop switch is faulty and should be exchanged.
- A 4. Should there still be no ignition, remove the starter and air conductor. Check all cables and connections. Cables that are squeezed or otherwise damaged should be exchanged.

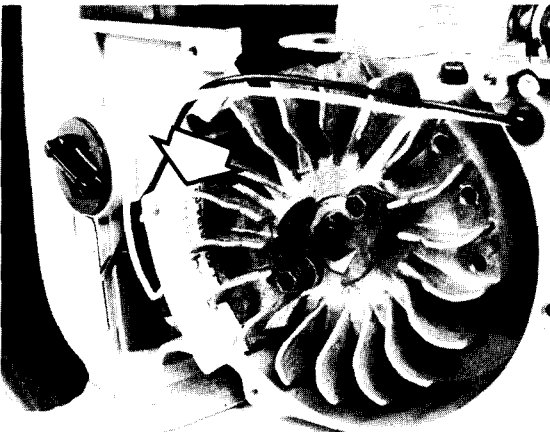
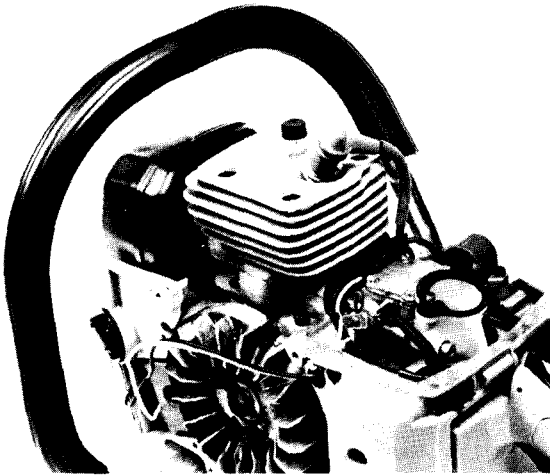

Check simultaneously the gap between the magnet of the flywheel and the core of the module. The gap should be 0.30 mm. Use air gap tool 50 25 134-02.

If no ignition after checks A 1 – A 4, the ignition coil should be exchanged by means of a special tester, eg our electric system tester No. 50 25 124-01 (see chapter 3).

If no ignition after checks A 1–A 4, the ignition coil should be exchanged and a new check made according to A 1.

The last step is to change the trigger module.

Check that the gap is exactly as stated above. Use air gap tool 50 25 134-02.

The ignition coil and trigger module may be checked by means of a special tester, eg our electric system tester No. 50 25 124-01 (see chapter 3).

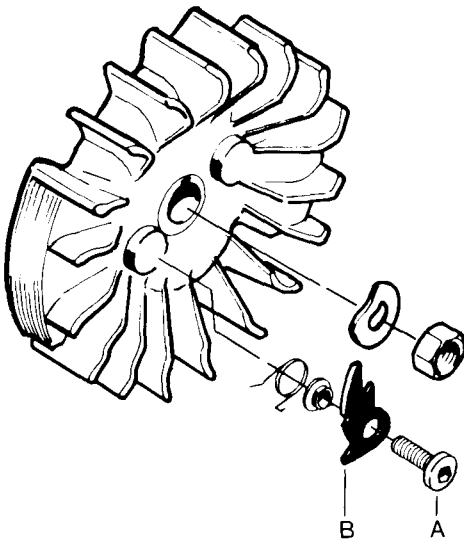

B. Removal of flywheel

Remove the starter and disconnect carefully the cables from the air conductor. Lift off the air conductor. Loosen the two screws A with Allen key No. 50 25 018-01 and remove the starter pawls B with the washers and springs.

Removal of oil pump

Remove the following parts in order to get at the oil pump: Clutch cover, chain and bar, centrifugal clutch (left-hand threads), clutch drum. Note the washer between the oil pump drive gear and the main bearing seal.

Loosen the socket head screws that retain the pump. Use Allen key No. 50 25 019-01.

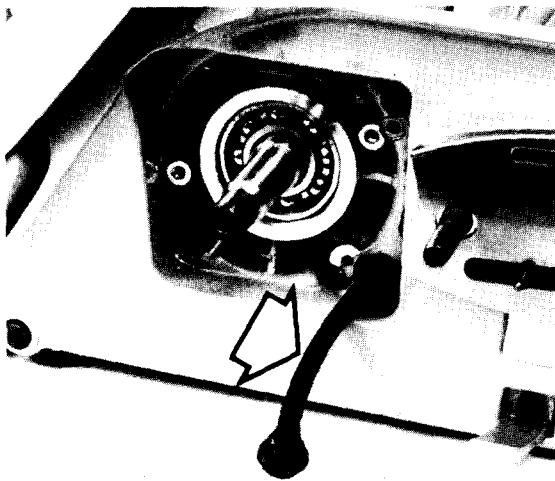
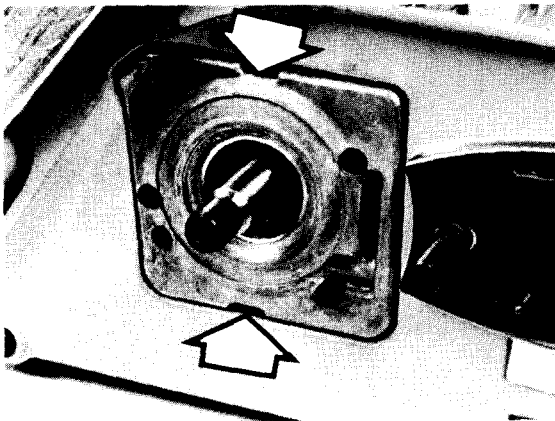
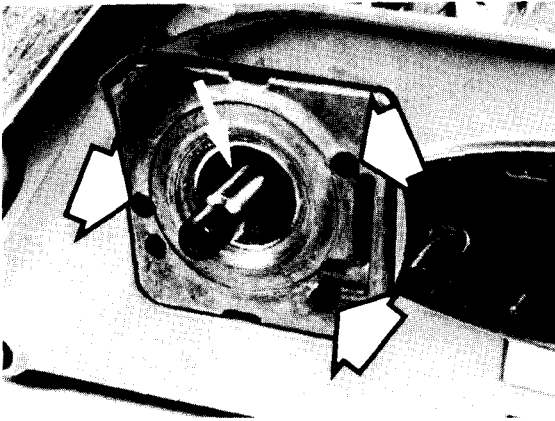

Remove the pump from the crankcase by levering around the edges of the housing with screwdrivers.

Lift the suction hose and oil filter out of the oil tank. Clean the parts and change any that may be damaged.

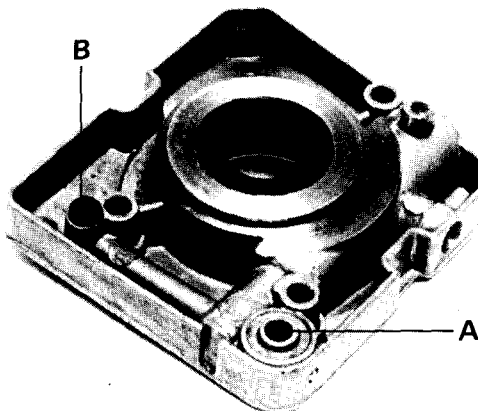

Check if there is dirt in the suction channel (A) by rotating the pump shaft in both directions. When the pump works properly and is filled with oil, the oil goes alternately through the suction channel and the compression channel (B).

5. Electric system

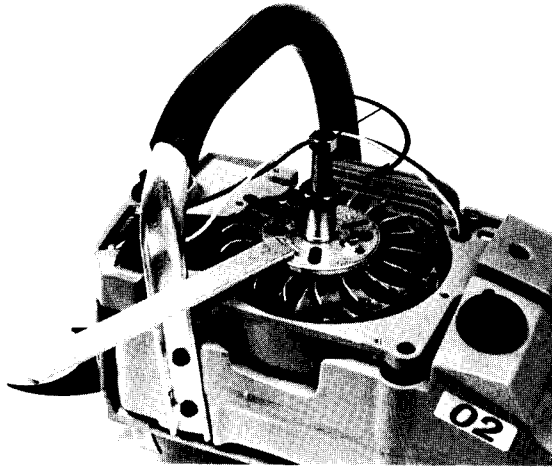

Fit holding bar No. 50 25 149-01 on the flywheel and loosen the nut with a box spanner (14 mm). Fit puller No. 50 25 026-01 on the holding bar and remove the flywheel.

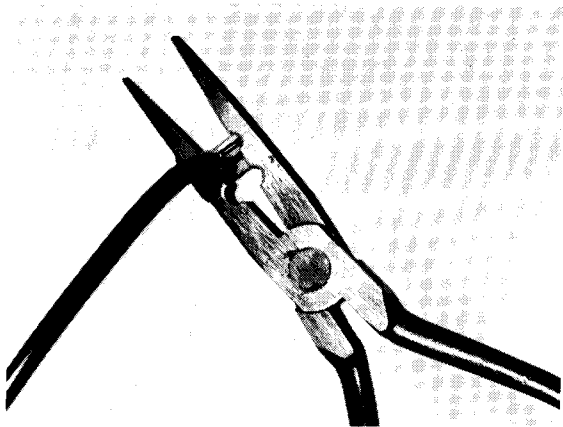

Assembly is made in reverse order. The flywheel nut should be tightened by torque 30–35 Nm. Do not forget the washer under the flywheel nut! Check the gap between flywheel and electronic unit. Use air gap tool No. 50 25 134-02.

Fitting the spark plug protector

To ensure proper connection between switch spring and ignition cable, use assembling pliers No. 50 25 006-01 for fitting the switch spring on the ignition cable.

Trouble shooting guide

	Adjusting screw in too high a setting	Adjusting screw worn	Guide pin worn	Dirt in the suction hose	Vacuum in the suction hose and oil filter	Pump piston seized	Suction hose cracked or leaking	Oil channel of crankcase clogged	Plastic driving gear damaged	Sealing ring damaged or lost
Too much lubrication	X	X								
Insufficient lubrication				X	X	X			X	X
Plastic driving gear damaged								X		
Lubrication only in felling position								X		
Leakage										X

6. Lubricating system

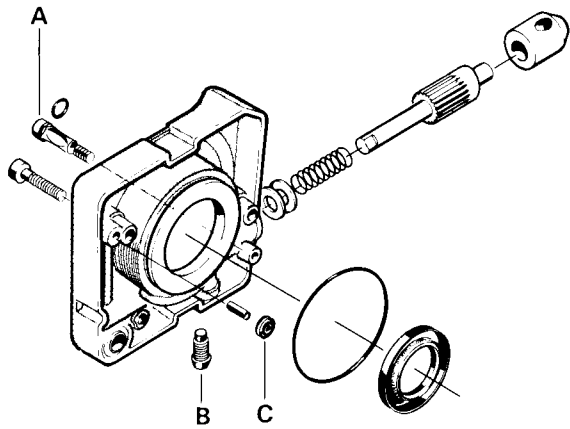

For cleaning, dismantle the pump as follows:

1. Remove the adjusting screw A.
2. Loosen locking screw B against which the cam curve of the pump drive runs. Check the wear of screw B. If worn, the screw should be changed.

3. Knock the edge of the pump housing against a piece of wood to make the pump piston slide out of the casing.

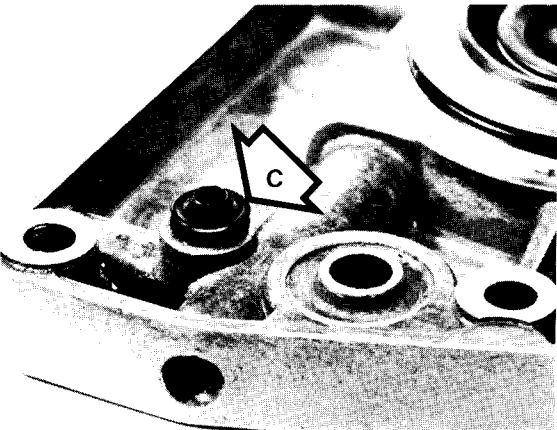
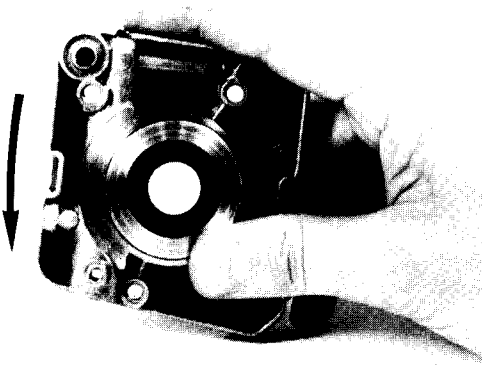

Assembly

Assembly of the oil pump is made in reverse order to dismantling.

1. Check that the sealing ring (C) on the pressure side is fitted, clean and undamaged.

Use sleeve No. 50 25 052-01 to protect the sealing ring when the pump is fitted into the crankcase.

2. After fitting the pump into the crankcase, check that the pump piston turns easily and that the return spring returns the pump drive towards the guide screw.



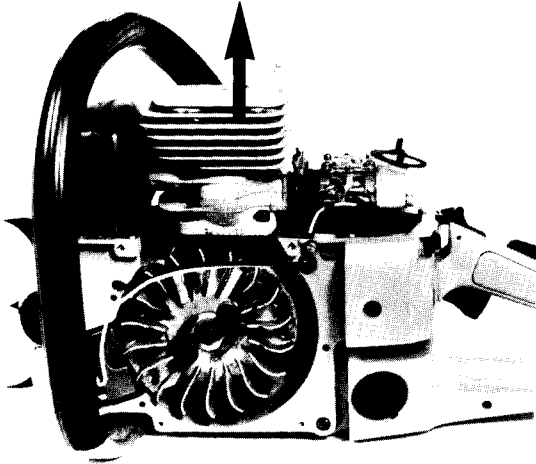

Removal

Lift off the cylinder cover. Remove the throttle push rod, fuel hose and choke control from the carburettor. Remove the spark plug protector, and the spark plug from the cylinder.

Loosen the screw that connects the air filter holder to the crankcase.

Loosen the four screws retaining the cylinder by means of Allen key No. 50 25 057-01.

Loosen also the two screws for the silencer support.



Lift the cylinder with silencer and carburettor.

To facilitate removal, the piston should be at the bottom dead centre.

Put a clean rag into the crankcase opening to protect the crankcase from the ingress of dirt, etc.

Remove the circlips on the wristpin with a pair of flat nose pliers and push out the wristpin.

Remove the silencer and the carburettor parts from the cylinder. Clean the external surface of the carburettor of dirt and sawdust. Scrape off carbon deposits from the exhaust port and combustion chamber.

Control

Check the following before assembly, and take the measures required:

Damage

Broken cooling fins, damaged threads or broken stud at exhaust port.

Seizure marks in the cylinder wall (especially at exhaust port).

Surface of the cylinder wall worn (esp. at the top).

Seizure marks on the piston.

Piston rings stuck in the groove.

Remedy

In case of severe damages, exchange the cylinder. Restore the thread by means of Heli-Coil inserts.

Polish the marks with a fine emery cloth to remove aluminium deposits.

If the marks are deep, exchange cylinder and piston.

Exchange cylinder and piston.

Polish the marks carefully with a fine file or emery cloth. Before fitting the piston, polish the cylinder wall as stated above. If the marks are deep, exchange the piston and, if necessary, the cylinder.

Remove the piston rings carefully and clean the grooves completely before mounting the rings. Check the wear of the piston rings by placing them in the bottom of the cylinder. The gap between the ends of the ring should be 2.8 mm max. Check that the rings are still springy.

Cylinder, Piston 7.

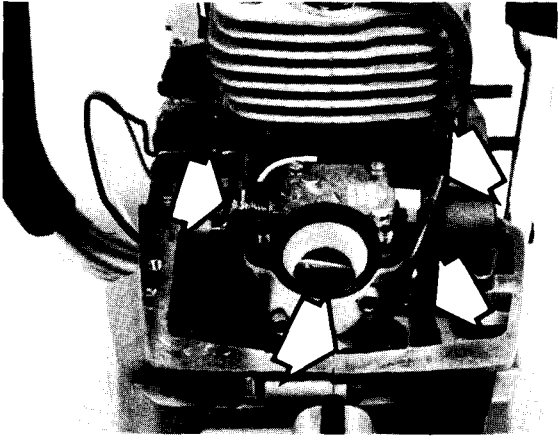

Connect the choke control, fuel hose and throttle push rod to the carburettor.
Fit the screw for the air filter elbow.

7. Cylinder, Piston

Assembly

Check that piston and cylinder have the same classification marking (see fig. classification table). Fit the insulating piece and the carburettor to the cylinder. Check that the gaskets are in the correct positions.

Place the cylinder base gasket on the crankcase. Check that the needle bearing of the wristpin is not damaged. Fit it in the connecting rod and lubricate with a few drops of two-stroke oil.

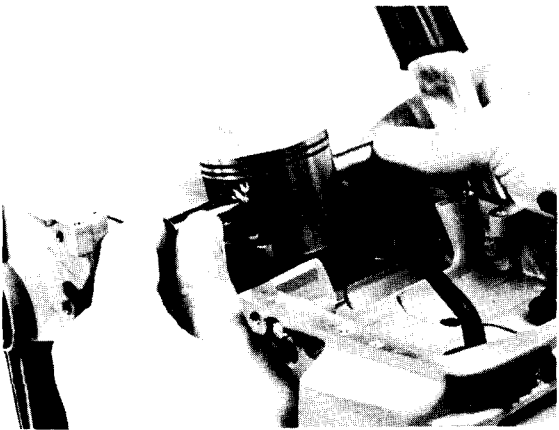
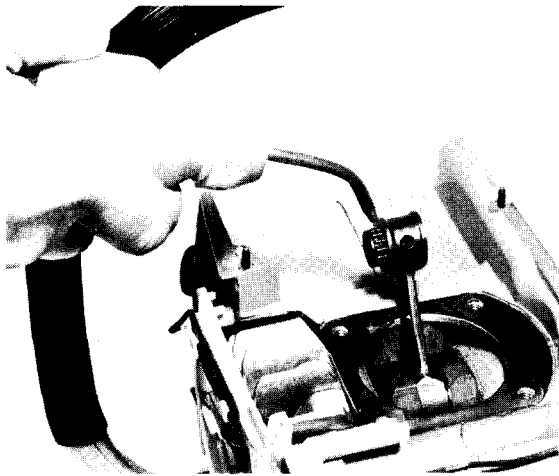

Fit the piston on the connecting rod. Note that the arrow on the piston should point towards the exhaust port! Push the wristpin in and fit the circlips. Turn them round with a pair of flat hose pliers to check that they run smoothly in the grooves.

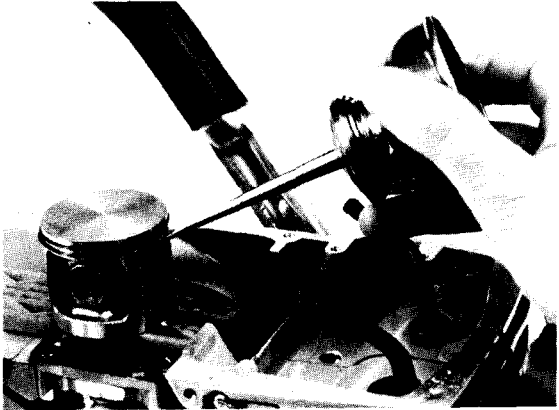

Lubricate the piston with a few drops of oil. Fit the supporting piece in mounting set No. 50 25 070-01 below the piston.

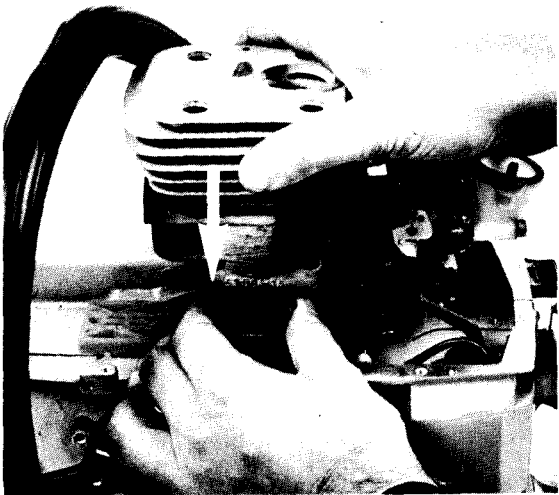

Press the piston rings by means of the piston ring compressor in mounting set No. 50 25 070-01. Push the cylinder carefully down over the piston. To avoid breaking the piston rings, do not turn the cylinder. Turn the crankshaft and check that the piston moves easily in the cylinder. Fit the plastic sleeve over the adjusting needles. Tighten the four cylinder base screws diagonally and evenly. Fit the silencer.

Removal of crankcase

The following components have already been removed: chain and bar, centrifugal clutch, flywheel, carburettor, cylinder and piston.

Drain the oil tank and fix the chain saw in the clamping device No. 50 25 102-01.

Remove the oil pump from the crankcase. Note the thrust!

Lift the oil hose and filter out of the oil tank.
Remove the cylinder base gasket.

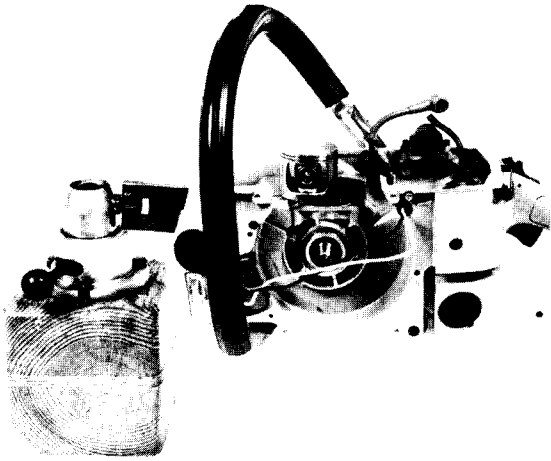

Remove the six screws (three on each side) that connect the crankcase to the tank unit.

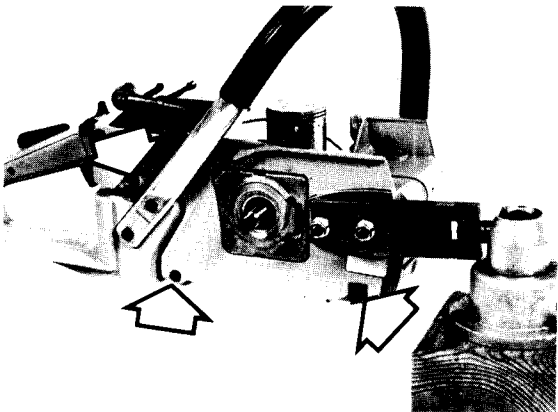

Separate the crankcase from the tank unit.

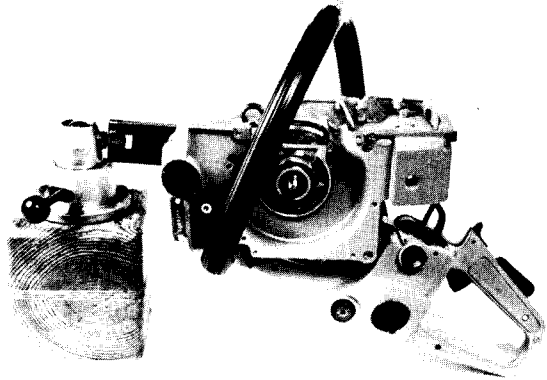

Remove the sealing ring on the magneto side with extractor 50 25 101-01.

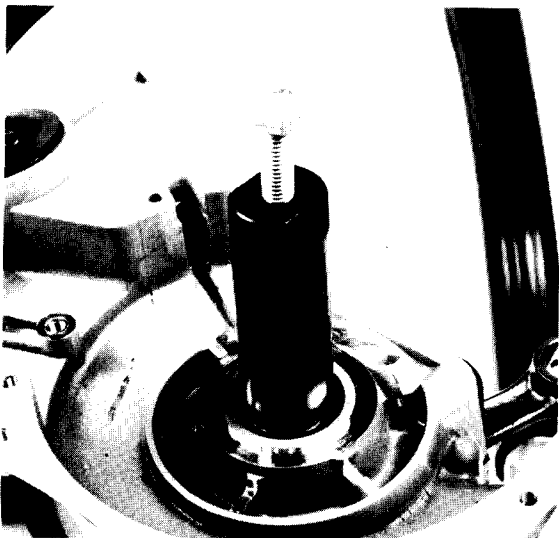

Assembling the crankcase

Fix the drive side of the crankcase in the clamping device. Warm up the bearing seats with a gas burner to abt 130° C.

Fit the ball bearing in the seat and locate it properly with fitting tool No. 50 25 030-08. Leave the crankcase in the clamping device to cool down.

Fit the ball bearing in the magneto side of the crankcase as described above, but on the work bench. Fitting tool is not necessary.

Grease the crankpins and fit the crankshaft, first in the drive side. Use fitting tool No. 50 25 030-08 to locate the crankshaft. Check that it reaches the bottom and that the connecting rod is properly located in the recess for the cylinder.

Turn the crankcase in the clamping device in order to get the crankshaft in an upright position. Grease the gasket face and fit a new gasket. Locate the magneto side of the crankcase ensuring that the gasket is not displaced.

Tighten the crankcase screws – but not completely.

Pull the magneto side in position with fitting tool No. 50 25 030-08. Check that the guide pins enter correctly.

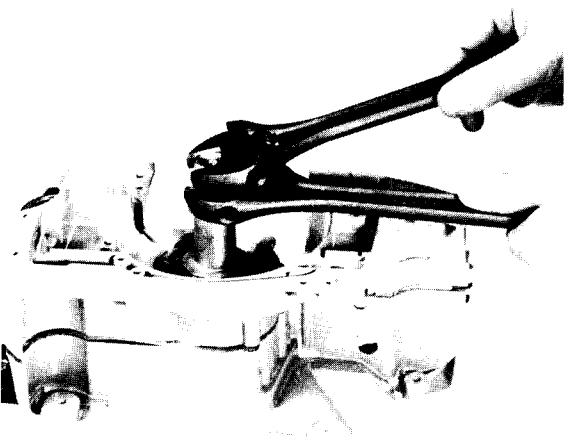
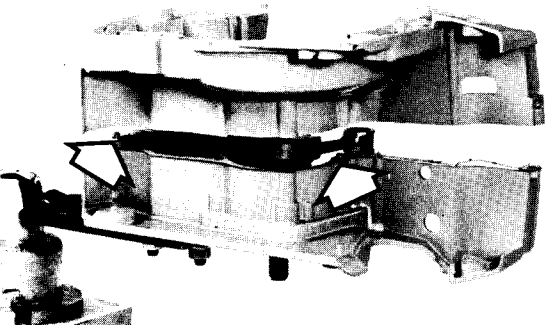
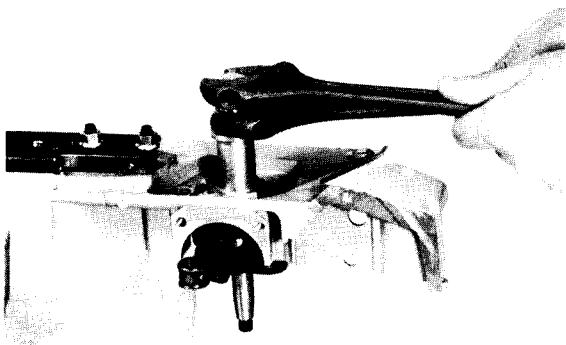
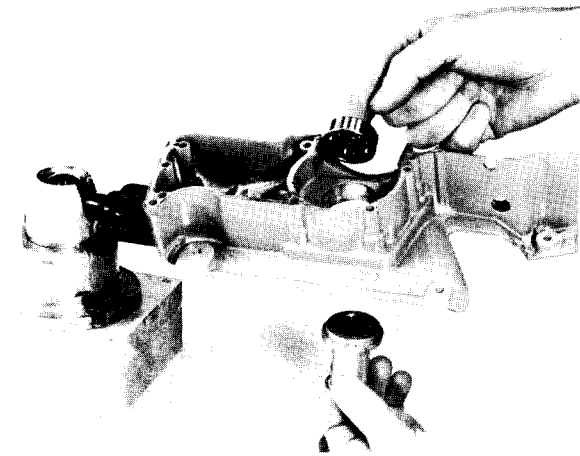

8 ■ Crankcase, Crankshaft

Remove the seven screws holding the crankcase halves together.

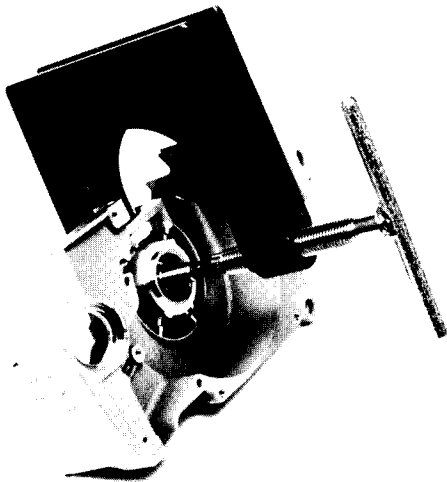
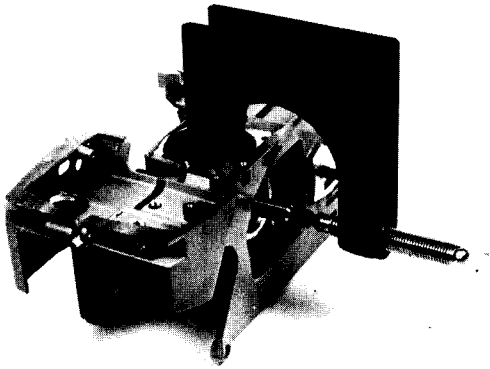
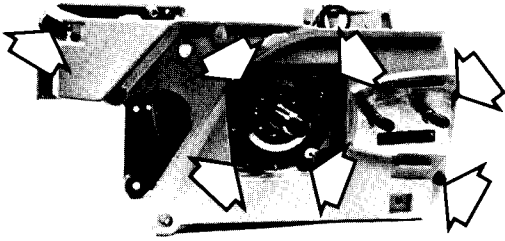

Separate the two crankcase halves by using puller 50 25 161-01.
Remove the ball bearings from the crankshaft with ball bearing puller No. 50 49 090-01.

Crankshaft check

A defective crankshaft must be replaced. Some crank webs may be blue coloured around the crankpin. This is, however, a normal result of the heat treatment around the crankpin hole. Check the big end of the connecting rod. Should there be seizure marks or discoloured spots on the sides, the crankshaft must be changed.

1.2-1.6 mm

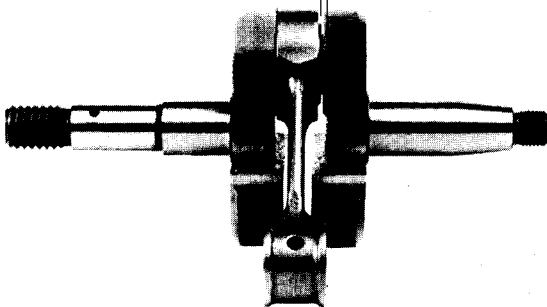

The connecting rod should not show any radial play (up and down). The axial play should, however, be 1.2 – 1.6 mm.

Changing the vibration dampers

Check the vibration dampers before reassembling the tank unit and the crankcase. If they are limp or damaged they should be changed. Use U-spanner No. 50 25 066-02.

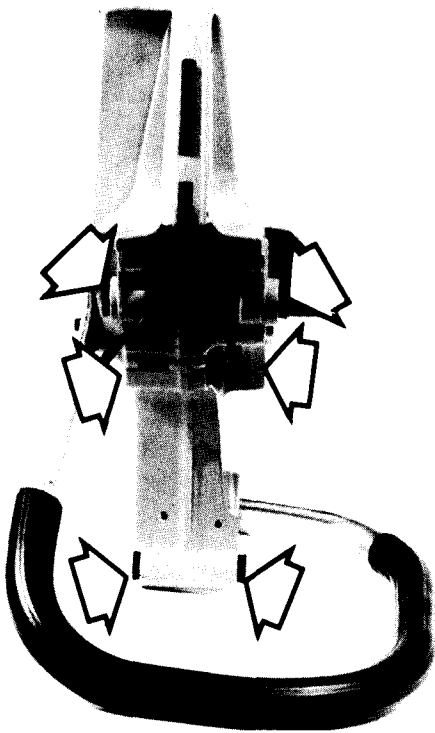

Assembly of crankcase — tank unit

Assembly of the crankcase-tank unit is made in reverse order.

8. Crankcase, Crankshaft

Tighten all screws, beginning nearest the crankshaft.
Check the position of the gasket and cut off its edges on the cylinder base surface.

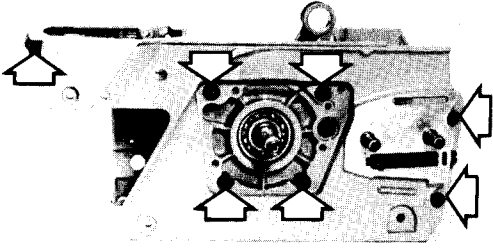

Check that the crankshaft rotates easily. If not, readjust it with the fitting tool.

The crankshaft must be properly centered in the crankcase!

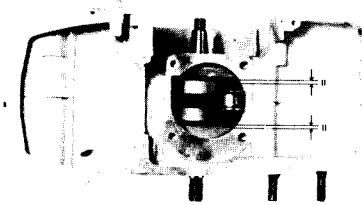

Fit the seal ring on the magneto side. Use fitting tool No. 50 25 030-08 but on the reverse side.

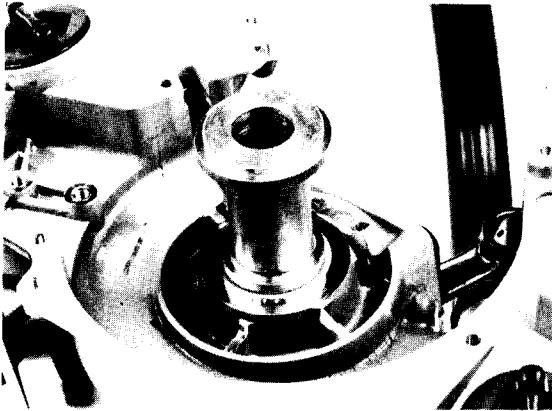

The distance between the sealing ring and the upper part of the seat (A) should be 3.5 mm. If less the flywheel will damage the sealing ring.

Fit the oil pump (see chapter 2).
Fit the cylinder and pressure test the crankcase (see chapter 2).

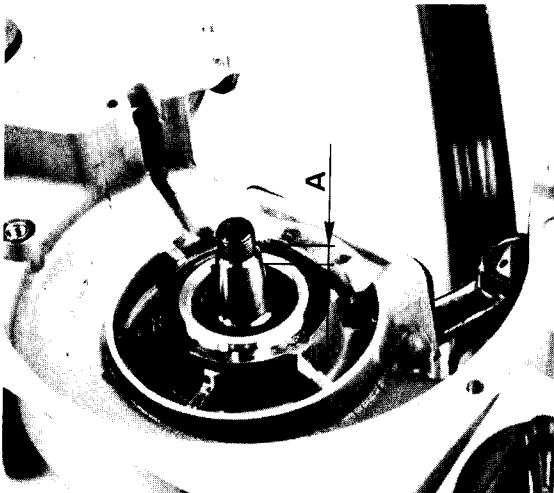

Removal

Remove the screws that retain the starter. Set the return spring to zero by pulling out the starting cord by abt 30 cm, put it into the groove of the pulley rim and let the wheel turn slowly backwards (slow it down with your thumb).

Loosen the screw and remove the washer in the centre of the pulley.

Lift off the pulley.

Remove the screws that retain the plastic cover over the return spring. Remove the cover and the spring.

Assembly

Put the return spring, a new one if necessary, into the starter housing. Lubricate with a few drops of ordinary engine oil.

Put the plastic cover back and tighten the screws.

If necessary, exchange the starting cord and fit it on the pulley. Wind up the cord 3 turns on the pulley (Note! right direction) and put it in its place in the starter housing. Check that the spring grips the pulley, then fit the washer and the screw.

Pull the cord through the cord sleeve of the starter housing and through the starting handle. Make a knot in the cord and pull the knot completely into the handle. Put the cord into the groove of the pulley rim and tighten the spring enough to get 1/4 spare round. Fit the starter and check that no electrical cables are squeezed.

NOTE!

It should be possible to turn the pulley a further 1/4 of a turn approx. with the cord pulled entirely out.

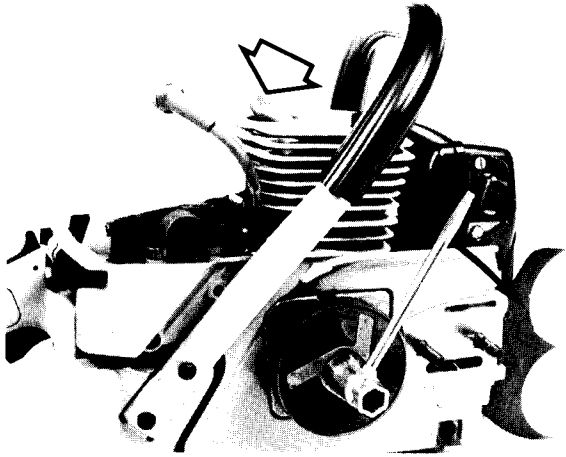

Removal

Fit the piston stop No. 50 25 033-01 into the spark plug hole. Remove the clutch centre by means of combination tool No. 50 15 375-01. **NOTE!** Left-hand threads. Lift off clutch centre and clutch drum. Do not lose the washer placed behind the drum.

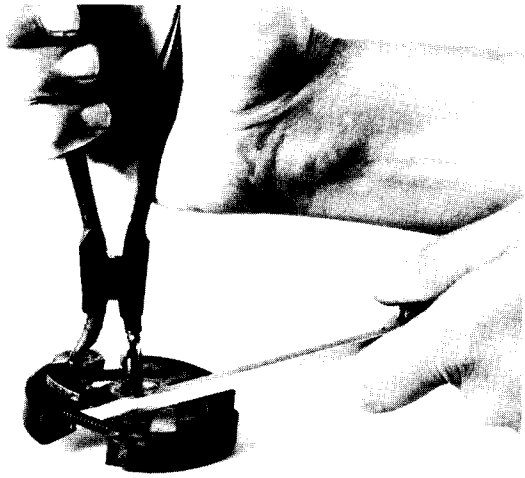

Changing the clutch spring

The clutch spring should be exchanged if it has been overheated (blue coloured) or broken. It is easily exchanged with pliers No. 50 25 049-01.

When fitting the new spring, check that its ends connect in the centre of a clutch shoe. Do not overstretch the spring!

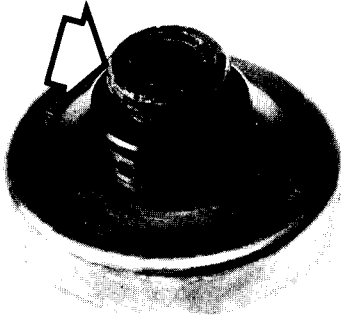

Changing the worm gear

The worm gear of the oil pump drive is easily removed from the clutch drum. It has four dogs which fit into four corresponding grooves in the clutch drum.

When fitting a new gear, put it in the clutch drum and check that it fits exactly into the grooves of the drum. Then fit the drum with gear on to the crankshaft.

Do not forget the washer behind the worm gear!

Checking wear

Check the wear of the clutch centre and the clutch shoes. There should be at least 1 mm left on the friction surface of the shoes.

All the shoes have to be exchanged on the same occasion.

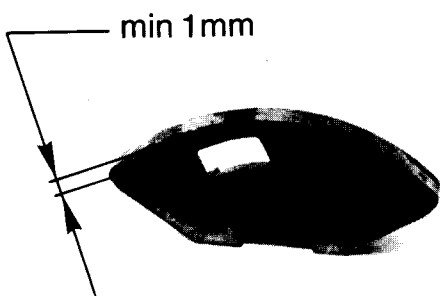

10. Centrifugal Clutch

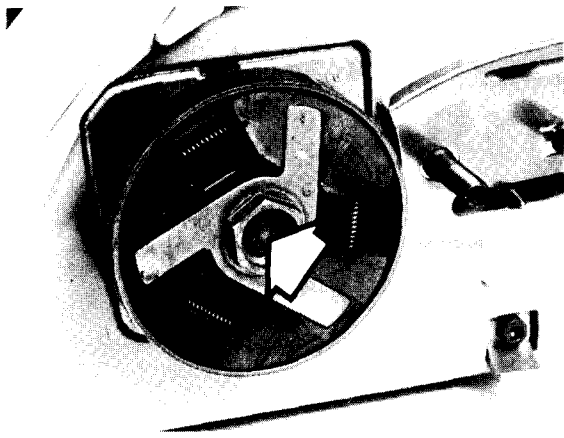

Lubrication

Lubricate the worm gear of the oil pump drive with Molykote before fitting the clutch drum. The needle bearing is to be lubricated with ball bearing grease. Two pumps with the grease gun into the hole of the crankshaft are sufficient.

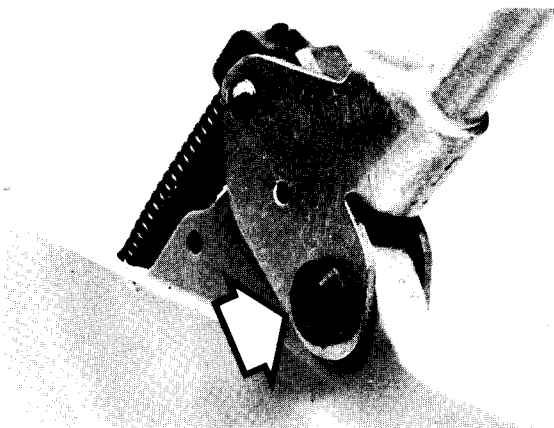

A. Chain brake

Removal

Remove the clutch cover and clean brake mechanism and brake band.
Fix the brake in the clamping device No. 50 25 102-01 and remove the Swed-o-Matic adjusting screw.
Release the brake.

Remove the screw from the front support of the hand guard by means of Allen key No. 50 25 019-01. Remove the two sleeves with a screw driver.

Loosen the nut (M) and lift off the hand guard.

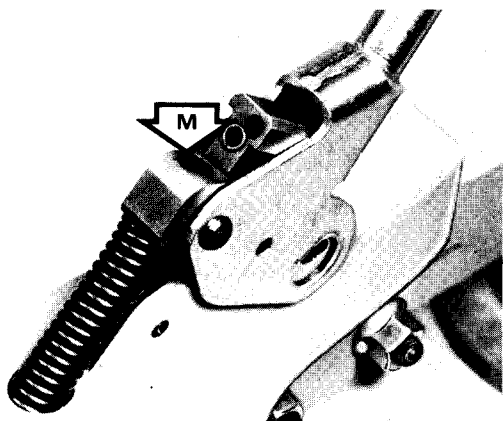

When dismantling the brake band use a drift \varnothing 4 mm to push out the roll pin.

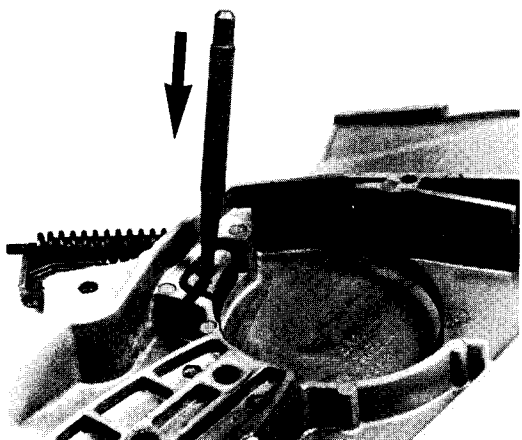

The catch may be changed after pushing out the roll pin with a drift \varnothing 4 mm.
Check the wear on the locking part of the catch (see A).

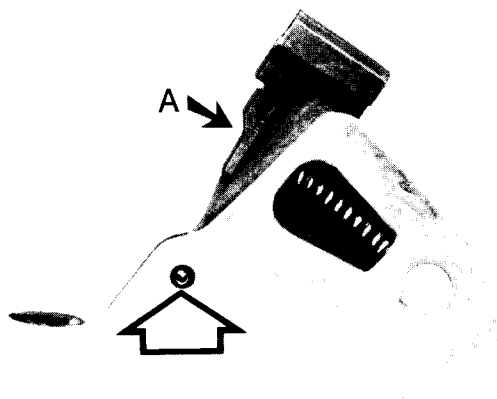

11. Safety Equipment

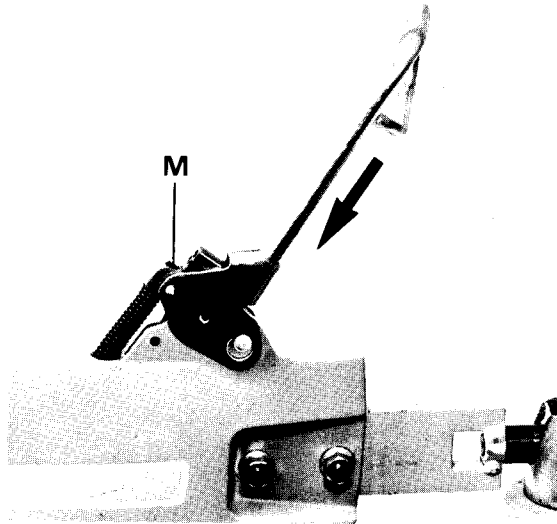

Assembly

The chain brake is assembled in reverse order to dismantling.

Before fitting the front sleeves, the hand guard must be locked (push it downwards).

The nut M should be tightened completely.

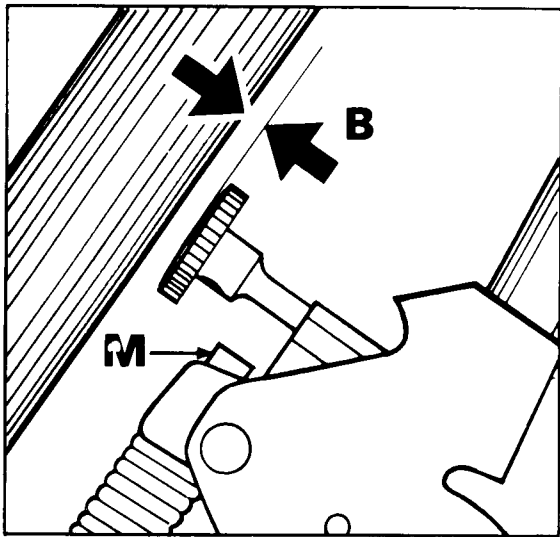

Adjusting the release power

The distance between the Swed-o-Matic release screw and the front handle (B) determines the release power. A smaller gap means reduced release power.

The release power can be checked as follows: Push the guide bar tip against a spring balance. With a 18'' guide bar the chain brake should be released at a load of 12–17 kp.

The forestry worker could make a rough check on the spot as follows:

Hold the saw horizontally over a trunk, at a height of abt 25 cm. As the saw by force of its own weight swings around the rear handle and hits the trunk, the brake should be released.

Note that during this check the engine must not be running.

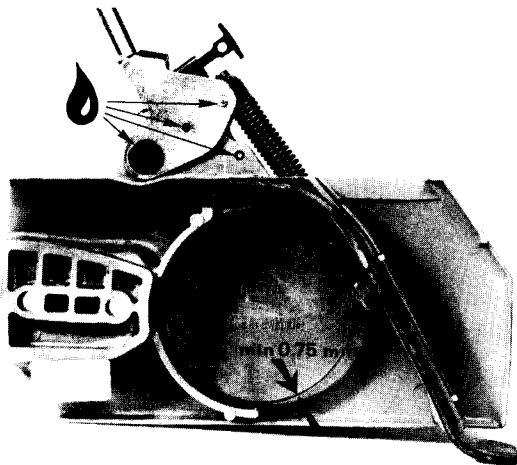

Maintenance of the chain brake

Clean the brake band and the mechanism. Check that the band has at least 0.75 mm thickness on the most worn part.

Lubricate the links and supports of the brake mechanism with twostroke oil. Release and lock the brake repeatedly to check that the mechanism works smoothly.

Check the chain brake function. Start the saw on clear ground making sure that the chain runs freely. Apply full throttle and release the chain brake. The chain should immediately stop rotating.

B. Changing the throttle safety catch and the throttle lever

Dismantle the tank unit as described in chapter 8, under the heading "Removal of crankcase".

Remove the two upper rear vibration dampers with U-spanner No. 50 25 066-02. Remove the throttle lever shaft and the lever.

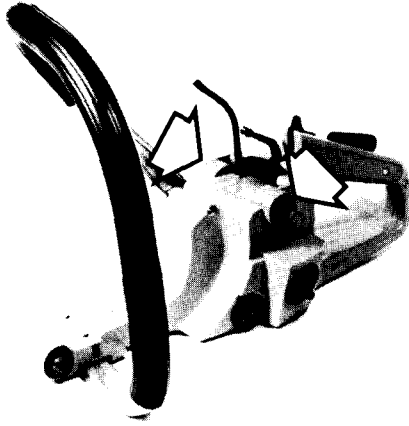

The safety catch is removed by pushing out the roll pin with a drift \varnothing 2 mm.

Reassembly is made in reverse order to dismantling.

Check that the spring enters the groove of the safety catch correctly and that the throttle lever works properly.

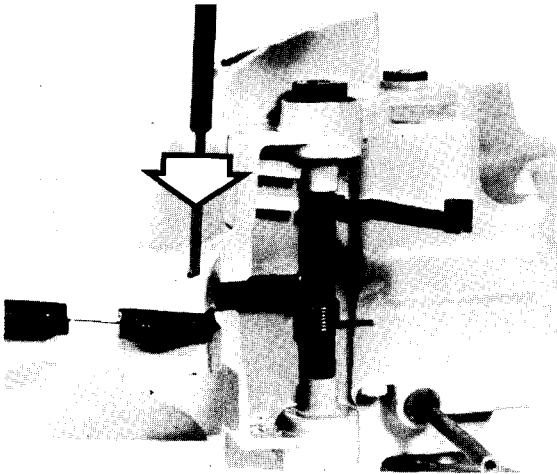

C. Changing the chain catcher

Do not forget to check the chain catcher and change it when damaged.

Remove the clutch cover. Use Allen key No. 50 25 018-01 to remove the screw retaining the chain catcher.

