

**Workshop manual**  
**340 345 346XP**  
**350 351 353**

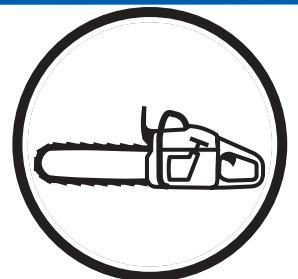

**English**

---

# Workshop manual

## Husqvarna 340/345/346XP/350/351/353

### Contents

<b>Introduction</b> .....	2
<b>Safety regulations</b> .....	3
General instructions .....	3
Special instructions .....	3
<b>Special tools</b> .....	4
<b>Technical data</b> .....	6
<b>Construction and function</b> .....	8
Carburettor .....	8
<b>Troubleshooting</b> .....	10
<b>Repair instructions</b> .....	12
Chain brake .....	12
Silencer .....	14
Chain catcher .....	14
Stop switch .....	15
Stop switch – resistance measurement.....	15
Choke control .....	16
Throttle trigger .....	17
Hand grip heater.....	18
Starter assembly .....	21
Starter cord.....	21
Recoil spring.....	22
Ignition module – testing .....	23
Ignition module and flywheel .....	23
Generator .....	24
Centrifugal clutch.....	26
Oil pump .....	27
Carburettor .....	30
Carburettor – pressure testing.....	33
Carburettor heater .....	34
Air intake system .....	35
Carburettor – adjustment.....	37
Fuel tank.....	38
Fuel filter.....	39
Fuel hose.....	39
Piston and cylinder .....	41
Decompression valve – pressure testing .....	42
Cylinder – pressure testing.....	44
Crankcase and crankshaft.....	45
Crankshaft bearings .....	46
Repairing damaged threads .....	49
Thread insert .....	49
Guide bar bolts .....	49
<b>Appendix A, Carburettor – EPA models</b> .....	50

---

# Introduction

## Arrangement of the manual

This workshop manual can be used in two different ways.

- To repair a specific sub-assembly on a chainsaw.
- To dismantle and reassemble a complete chainsaw.

## Repairing a specific sub-assembly

If a specific sub-assembly on the chainsaw needs to be repaired:

1. Look up the page referring to the relevant sub-assembly.
2. Follow the instructions under the headings:
  - Removal/Dismantling
  - Cleaning and inspection
  - Refitting/Reassembly

## Dismantling and reassembling the entire chainsaw

If the entire chainsaw is to be dismantled, follow the instructions under the heading “Removal/Dismantling”.

Work through the manual and follow the instructions given in each section under the heading “Removal/Dismantling”.

Then follow all the “Cleaning and inspection” instructions in each section.

Working from the back of the manual, follow all the instructions under the headings “Refitting/Reassembly” in reverse order.

Each of the sections covering removal/dismantling and refitting/reassembly include the relevant lubrication instructions and bolt torques for each stage of repair.

## Construction and function

This chapter gives a simple description of the chainsaw carburettor and its various parts.

## Troubleshooting

These pages describe the most common faults that affect a chainsaw. They are divided into four different groups with the most likely faults described first.

## Repair instructions

The section that describes how to repair the chainsaw consists of detailed, step-by-step instructions. It explains in detail the special tools, lubricants and bolt torques that are needed when working on each component.

**This workshop manual covers the following chainsaw models:**

**340**  
**345**  
**346XP**  
**350**  
**351**  
**353**

# Safety regulations

## General instructions

This workshop manual gives detailed instructions on how to troubleshoot, repair and test a chainsaw. This section also describes the various safety precautions that should be taken when carrying out repairs.

The workshop manual has been written for personnel who are assumed to have general experience of repairing and servicing chainsaws.

Workshops where chainsaws are repaired must be equipped with safety equipment that meets local regulations.

No-one should carry out repairs on a chainsaw until they have read and understood the contents of this workshop manual.

Chainsaws are type-approved to meet the relevant safety legislation, but this only applies when the saw is fitted with the cutting equipment specified in the user's manual. The fitting of any other equipment, or of accessories or parts that are not approved by Jonsered, could mean that the saw no longer meets these safety requirements and the person who carried out the work may be held responsible for its non-conformance.

In this workshop manual the following boxes indicate where caution should be taken.



**WARNING!**  
The warning text warns of the risk of personal injury if the instructions are not followed.

### NOTE!

The warning text warns of the risk of material damage if the instructions are not followed.

## Special instructions

The fuel that is used in a chainsaw poses the following hazards:

- The fuel and its fumes are toxic.
- May cause irritation to skin or eyes.
- May cause breathing difficulties.
- Highly flammable.

When using compressed air the air jet should never be pointed at the body. Air can be forced into the bloodstream and cause fatal injury.

Wear ear protection when testing saws.

After testing a saw do not touch the silencer until it has cooled down. The silencer gets very hot and you may burn yourself. Wear protective gloves when working on the silencer.

The guide bar, chain and clutch cover (chain brake) must be fitted before the saw is started. If not, the clutch may come loose and cause injury.

Poor chain lubrication can result in failure of the chain, which could cause serious or fatal injury.

Take care to ensure that the spring inside the starter assembly does not fly out and cause injury. Wear eye protection. If the spring is under compression when the pulley is removed it could fly out and cause injury.

Before removing the tensioning spring from the chain brake, ensure that the brake is in the on position, otherwise the spring may fly out and cause injury.

After completing the repair the chain brake must be tested, see "Chain brake – reassembly \ Operating test".

Always consider the fire risk. A chainsaw can produce sparks that could start a fire.

Inspect the chain catcher and replace it if it is damaged.

# Special tools

1

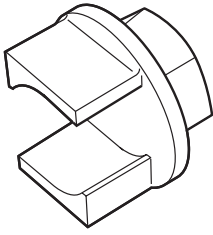

2

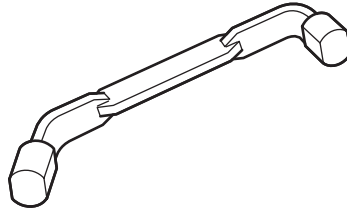

3

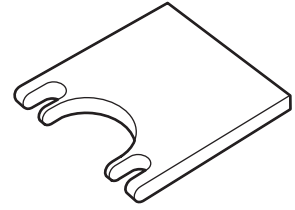

4

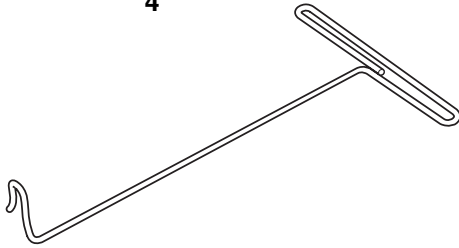

5

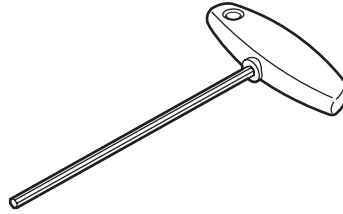

6

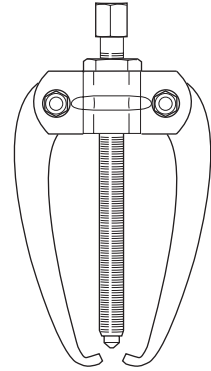

7

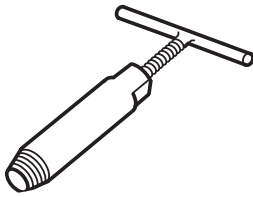

8

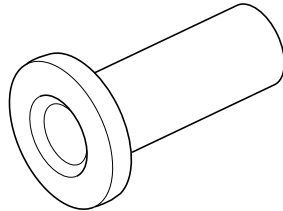

9

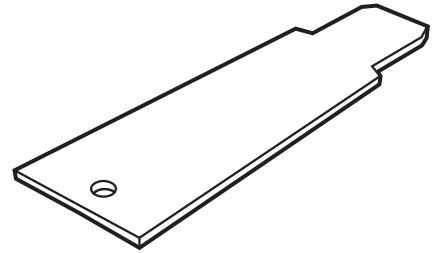

10

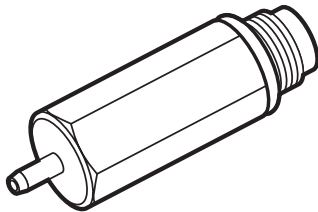

11

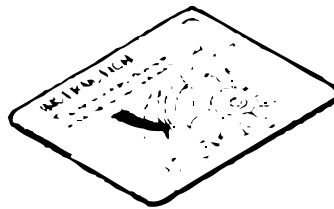

12

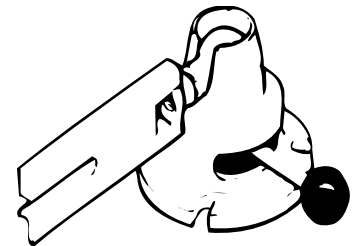

13

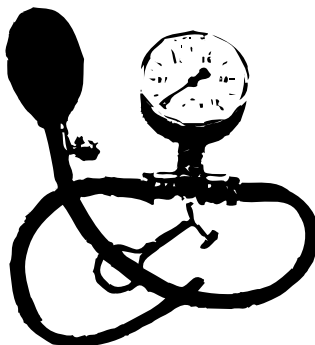

14

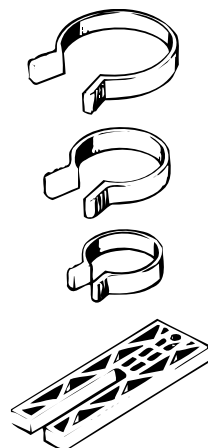

15

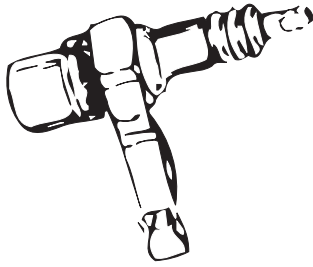

16

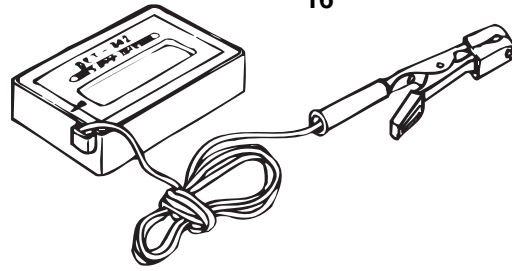

17

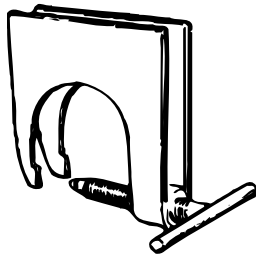

18

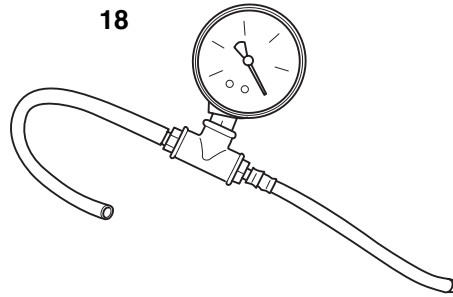

19

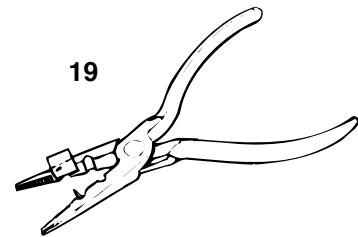

20 b

20 c

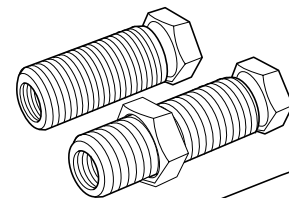

20 a

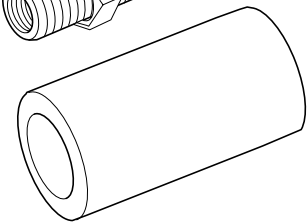

21

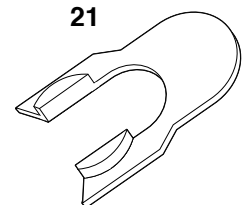

22

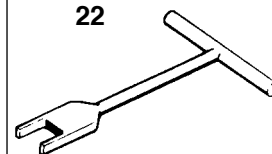

23

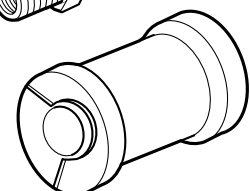
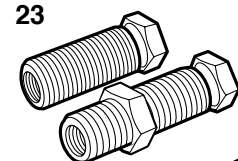

Item	Description	Used for	Order no.
1	Clutch tool	Centrifugal clutch	502 54 16-02
2	Piston stop	Locking crankshaft	502 54 15-01
3	Stop plate	Locating intake gaiter	502 54 17-01
4	Fuel filter hook	Withdrawing the fuel filter	502 50 83-01
5	Allen key	For M5 bolts	502 50 18-01
6	Puller	Frame bearing	504 90 90-02
7	Removal tool	Remove seal from clutch side	502 50 55-01
8	Mandrel, sealing ring	Removing crankshaft	502 54 21-01
9	Cover plate	Sealing during pressure testing	502 54 11-02
10	Pressure tester	Connection to cylinder	503 84 40-02
11	Feeler gauge	Adjusting ignition module	502 51 34-02
12	Clamp stand	Clamping the saw	502 51 02-01
13	Pressure gauge	Pressurisation during testing	502 50 38-01
14	Piston fitting kit	Fitting piston	502 50 70-01
15	Test plug	Checking ignition module	502 71 13-01
16	Rev counter	Adjusting carburettor	502 71 14-01
17	Removal tool	Removing crankshaft	502 51 61-01
18	Vacuum gauge	Vacuum test	502 50 37-01
19	Assembly pliers	Fitting spark plug guard	502 50 06-01
20a	Sleeve	Fitting crankshaft	502 50 30-18
20b	Shaft extension	Flywheel side	502 50 30-18
20c	Shaft extension	Clutch side	502 50 30-18
21	Stop plate	Removing crankshaft	502 54 18-01
22	Assembly tool	Assembling spring, chain brake	502 50 67-01
23	Crankshaft tool	Fitting crankshaft seal	502 50 30-16

# Technical data



Displacement  
cm<sup>3</sup>/cubic inches

340:	40,8 / 2,44
345:	45,0 / 2,75
346XP/G:	45,0 / 2,75
350:	49,4 / 3,01
350 EPA:	51,7 / 3,15
351/G:	49,4 / 3,01
353/G:	51,7 / 3,15

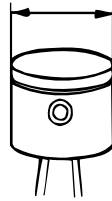

Cylinder bore  
Ø mm/Ø inches

40 / 1,57"
42 / 1,65"
42 / 1,65"
44 / 1,73"
45 / 1,77"
44 / 1,73"
45 / 1,77"

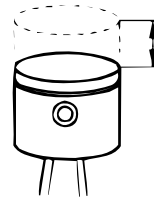

Stroke  
mm/inches

32 / 1,28"
32 / 1,28"
32 / 1,28"
32 / 1,28"
32 / 1,28"
32 / 1,28"
32 / 1,28"

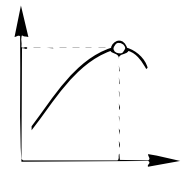

Max power/speed  
kW/hp/rpm

2,0 / 2,7 / 9 000
2,2 / 3,0 / 9 000
2,5 / 3,4 / 9 600
2,3 / 3,1 / 9 000
2,3 / 3,1 / 9 000
2,3 / 3,1 / 9 000
2,4 / 3,3 / 9 000

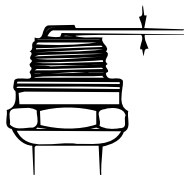

Spark plug gap  
mm/inches

340:	0,5 / 0,02"
345:	0,5 / 0,02"
346XP/G:	0,5 / 0,02"
350:	0,5 / 0,02"
350 EPA:	0,5 / 0,02"
351/G:	0,5 / 0,02"
353/G:	0,5 / 0,02"

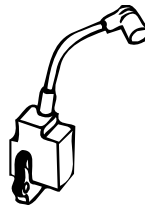

Ignition system

SEM CD
SEM CD
SEM CD
SEM CD
SEM CD
SEM CD
SEM CD

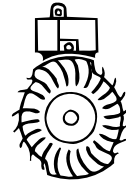

Air gap  
mm/inches

0,3 / 0,012"
0,3 / 0,012"
0,3 / 0,012"
0,3 / 0,012"
0,3 / 0,012"
0,3 / 0,012"
0,3 / 0,012"



Carburettor type

Walbro HDA 195
Walbro HDA 195
Zama C3-EL17
Walbro HDA 195
Zama C3-EL18
Zama C3-EL17
Zama C3-EL17

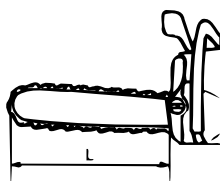

Effective cutting length  
cm/inches

340:	30-48 / 12"-19"
345:	30-48 / 12"-19"
346XP/G:	30-48 / 12"-19"
350:	30-48 / 12"-19"
350 EPA:	30-48 / 12"-19"
351/G:	30-48 / 12"-19"
353/G:	30-48 / 12"-19"



Chain speed at  
max power – revs  
m/s – rpm

17,3 / 9 000
17,3 / 9 000
18,5 / 9 600
17,3 / 9 000
17,3 / 9 000
17,3 / 9 000
17,3 / 9 000

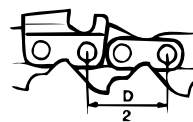

Chain pitch  
mm/inches

8,25 / 0,325"
8,25 / 0,325"
8,25 / 0,325"
8,25 / 0,325"
8,25 / 0,325"
8,25 / 0,325"
8,25 / 0,325"

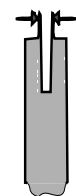

Drive link  
mm/inches

1,3 / 0,050" - 1,5 / 0,058"
1,3 / 0,050" - 1,5 / 0,058"
1,3 / 0,050" - 1,5 / 0,058"
1,3 / 0,050" - 1,5 / 0,058"
1,3 / 0,050" - 1,5 / 0,058"
1,3 / 0,050" - 1,5 / 0,058"
1,3 / 0,050" - 1,5 / 0,058"

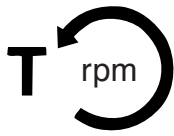

Idling speed  
rpm

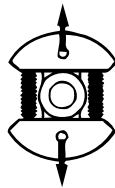

Engagement speed  
rpm

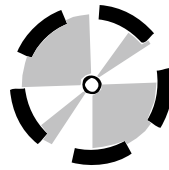

Max. speed  
rpm



Spark plug

340:	2 700	3 800	12 500	NGK BPMR 7A, Champion RCJ 7Y
345:	2 700	3 800	12 500	NGK BPMR 7A, Champion RCJ 7Y
346XP/G:	2 700	3 800	14 200	NGK BPMR 7A, Champion RCJ 7Y
350:	2 700	3 800	13 000	NGK BPMR 7A, Champion RCJ 7Y
350 EPA:	2 700	3 800	13 000	NGK BPMR 7A, Champion RCJ 7Y
351/G:	2 700	3 800	13 000	NGK BPMR 7A, Champion RCJ 7Y
353/G:	2 700	3 800	13 000	NGK BPMR 7A, Champion RCJ 7Y



Fuel tank capacity  
Litres/US pints

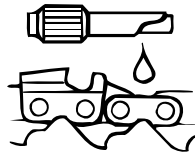

Oil pump capacity at  
8,500 rpm,  
ml/min



Oil tank capacity  
Litres/US pints

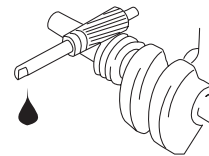

Automatic oil pump

340:	0,5 / 1,05	9	0,25 / 0,53	Yes
345:	0,5 / 1,05	9	0,25 / 0,53	Yes
346XP/G:	0,5 / 1,05	5 - 12	0,28 / 0,59	Yes
350:	0,5 / 1,05	5 - 12	0,26 / 0,55	Yes
350 EPA:	0,5 / 1,05	5 - 12	0,26 / 0,55	Yes
351/G:	0,5 / 1,05	5 - 12	0,28 / 0,59	Yes
353/G:	0,5 / 1,06	5 - 12	0,28 / 0,59	Yes



Weight without bar and chain  
kg / lbs



Weight with bar and chain  
kg / lbs



Heated hand grips

340:	4,7 / 10,3	5,5 / 12,1	-
345:	4,7 / 10,3	5,5 / 12,1	-
346XP:	4,8 / 10,6	5,6 / 12,2	-
346XPG:	4,9 / 10,8	5,7 / 12,4	Yes
350:	4,8 / 10,6	5,6 / 12,2	-
350 EPA:	4,8 / 10,6	5,6 / 12,2	-
351:	4,8 / 10,6	5,6 / 12,2	-
351G:	4,9 / 10,8	5,7 / 12,4	Yes
353:	5,0 / 11,0	5,8 / 12,6	-
353G:	5,1 / 11,2	5,9 / 13,0	Yes



# Construction and function

## Carburettor

The carburettor consists of three sub-systems:

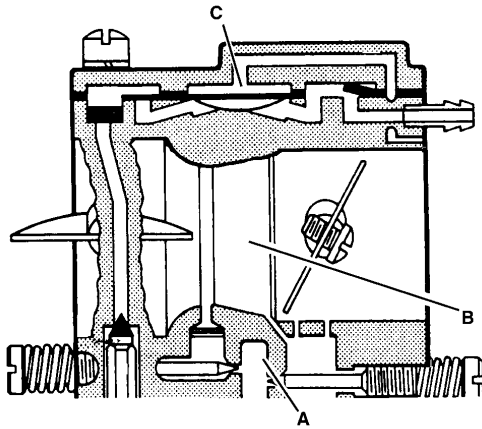

- The **metering unit** (A) which contains the jets and the fuel control mechanism. This measures out the right amount of fuel to suit the speed of the saw and the power demand.
- The **mixing unit** (B) consists of the choke, diffuser jets and throttle valve. This is where the air and fuel are mixed to create a flammable mixture.
- The **pump unit** (C) pumps fuel from the tank to the metering system inside the carburettor. One side of the pump diaphragm is connected to the crankcase and pulses as a result of pressure changes in the crankcase. The other side of the diaphragm sucks in the fuel.

The carburettor works in different ways depending on the setting:

- Cold start mode
- Idling mode
- Part throttle mode
- Full throttle mode

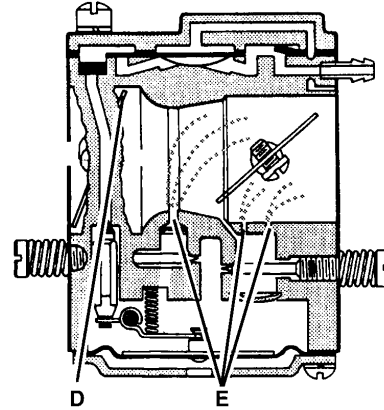

In the cold start mode the choke valve (D) is completely closed. This increases the vacuum in the carburettor so that fuel is sucked through the diffuser jets faster (E).

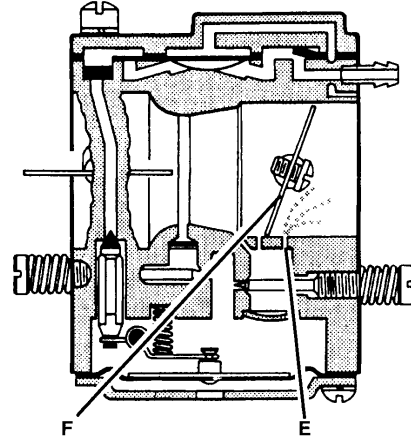

In idling mode the throttle valve (F) is closed. Air is sucked through an aperture in the throttle valve and a small amount of fuel is supplied through the diffuser jet (E).

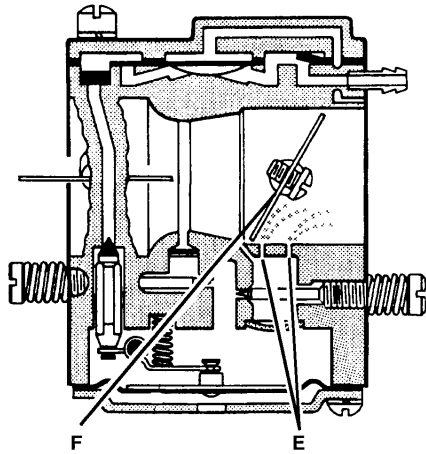

In part throttle mode the throttle valve (F) is partially open. Fuel is supplied through the diffuser jets (E).

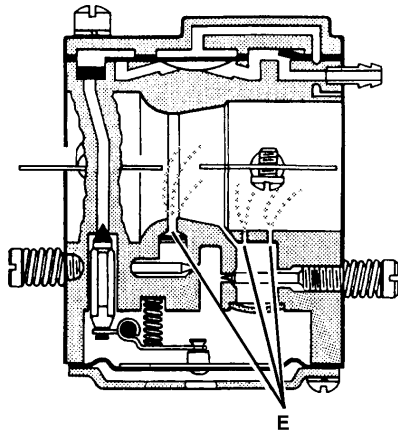

In full throttle mode both valves are open and fuel is supplied through all the diffuser jets (E).

# Troubleshooting

The various faults that can affect a chainsaw are divided into four groups. In each group the likely symptoms are given on the left and possible causes are listed on the right. The most likely faults are given first, and so on.

## Starting

Difficulty starting	Adjust L screw Air filter blocked Choke not working Worn choke pivot Worn choke valve Fuel filter blocked Fuel line blocked Piston ring seized Blocked impulse channel
Carburettor leaking fuel	Loose or faulty fuel pipe Hole in diaphragm Worn needle valve Needle valve assembly sticking Needle valve set too high Leak in metering system (air or fuel) Loose cover on carburettor pump side
Flooding when engine not running	Worn needle valve Needle valve set too high Needle valve assembly sticking

## Idling (low rpm)

Will not idle	Adjust L screw Leaking air intake hose (rubber) Loose carburettor mounting bolts Loose or faulty fuel hose Fuel filter blocked Fuel line blocked Fuel tank vent blocked Throttle valve pivot stiff Throttle pushrod sticking Defective throttle return spring Bent throttle stop Faulty diffuser jet
Idling too rich	Adjust L screw Worn needle valve Needle valve set too high Worn needle valve lever Leaking control diaphragm/cover plate Needle valve assembly sticking

## Idling (low rpm) (cont.)

Idles when L screw closed	Worn needle valve Leaking control diaphragm/cover plate Needle valve assembly sticking Worn needle valve lever Faulty diffuser jet
Idling uneven	Fuel filter blocked Fuel line blocked Leaking air intake hose (rubber) Loose carburettor mounting bolts Worn throttle valve pivot Loose throttle valve screw Worn throttle valve Needle valve assembly sticking Leak in metering system (air or fuel) Metering system centre knob is worn Hole in diaphragm Leaking control diaphragm/cover plate Crankcase leaking
L screw requires constant adjustment	Fuel line blocked Needle valve set too high Needle valve assembly sticking Leak in metering system (air or fuel) Leaking control diaphragm/cover plate Faulty diffuser jets Crankcase leaking
Too much fuel at idling	Needle valve set too high Needle valve assembly sticking Metering system damaged Worn needle valve Leaking control diaphragm/cover plate Metering system incorrectly assembled

**High rpm**

Will not run at full throttle	Adjust H screw Blocked air filter Blocked fuel tank vent Blocked fuel filter Fuel line blocked Loose or damaged fuel hose Impulse channel leaking Impulse channel blocked Loose cover on carburettor pump side Faulty pump diaphragm Leaking air intake hose (rubber) Loose carburettor mounting bolts Needle valve set too low Metering system damaged Metering system incorrectly assembled Leaking control diaphragm/cover plate Needle valve assembly sticking Blocked silencer
Low power	Adjust H screw Blocked fuel tank vent Blocked fuel filter Impulse channel leaking Impulse channel blocked Loose cover on carburettor pump side Faulty pump diaphragm Blocked air filter Needle valve assembly sticking Leak in metering system (air or fuel) Metering system incorrectly assembled Loose diaphragm rivet Hole in diaphragm Leaking control diaphragm/cover plate
Will not “four-stroke”	Blocked fuel tank vent Blocked fuel filter Fuel line blocked Loose or damaged fuel hose Impulse channel leaking Impulse channel blocked Loose cover on carburettor pump side Faulty pump diaphragm Leaking air intake hose (rubber) Loose carburettor mounting bolts Needle valve set too low Leak in metering system (air or fuel) Metering unit incorrectly assembled Loose diaphragm rivet Hole in diaphragm Leaking control diaphragm/cover plate

**Acceleration and retardation**

Does not accelerate	Adjust L screw Adjust H screw Blocked air filter Blocked fuel tank vent Blocked fuel filter Fuel line blocked Loose or damaged fuel hose Impulse channel blocked Loose cover on carburettor pump side Faulty pump diaphragm Leaking air intake hose (rubber) Loose carburettor mounting bolts Needle valve set too low Metering system incorrectly assembled Needle valve assembly sticking Faulty diffuser jets Blocked silencer
Engine stalls when throttle released	Adjust L screw Adjust H screw Faulty pump diaphragm Needle valve set too high Needle valve assembly sticking Faulty diffuser jets
Over rich acceleration	Adjust L screw Adjust H screw Blocked air filter Faulty pump diaphragm Faulty diffuser jets

**Troubleshooting methods**

In addition to the faults described in the above table, trouble shooting can be carried out on specific components or sub-systems of the chainsaw. The various procedures are described in the relevant chapters, see the contents page, as follows:

- Checking the operation of the chain brake
- Measuring the resistance of the stop plate
- Pressure testing the carburettor
  
- Pressure testing the decompression valve
- Pressure testing the cylinder

# Repair instructions

## Chain brake – dismantling

1

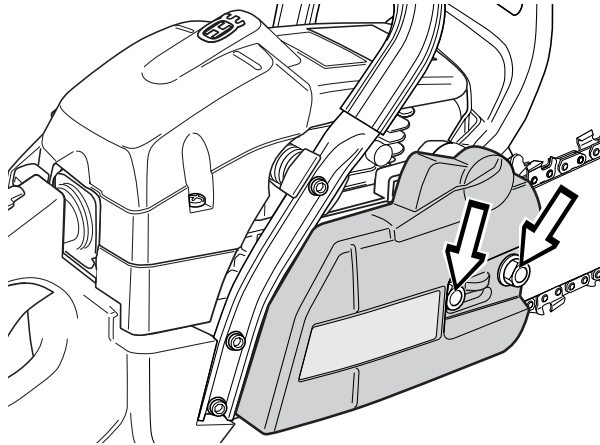

Disengage the brake by pushing the kickback guard backwards. Unscrew the guide bar bolts and remove the clutch cover, chain and guide bar.

2

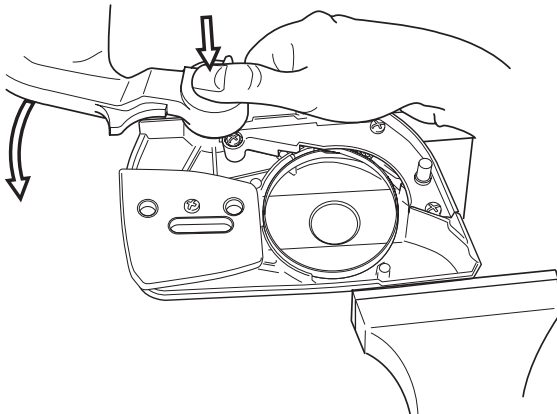

Grip the clutch cover carefully in a vice. Release the brake spring by using the kickback guard from the saw as a tool. Engage it with the brake mechanism and turn anticlockwise to activate the brake.

3



**WARNING!**  
Make sure the spring does not fly out and cause injury. Wear eye protection.

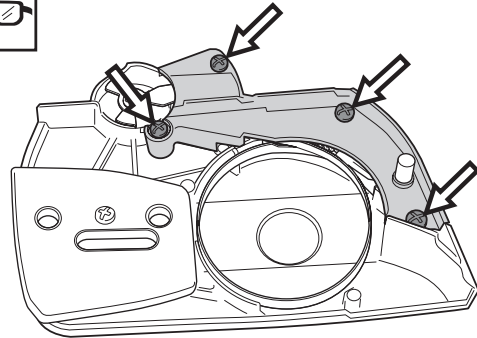

Remove the screws and carefully remove the cover from the chain brake spring.

4

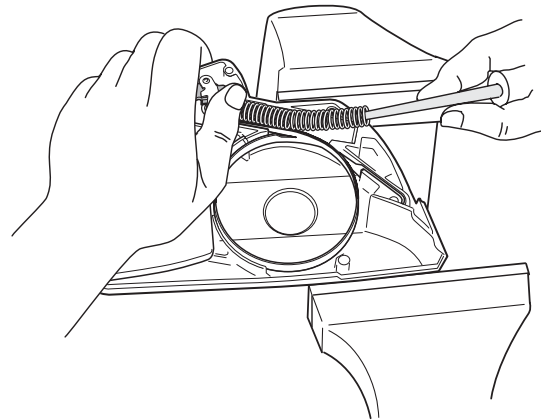

Place one hand over the spring and insert a small screwdriver between the bottom end of the spring and the clutch cover. Carefully prise the spring upwards so that it slides onto the screwdriver shaft.

## Cleaning and inspection

- Clean and inspect all parts carefully. If there are any cracks or other defects replace the damaged parts with new ones. Always use original parts.
- Measure the thickness of the chain brake band. It must be no less than 0.6 mm at any point.
- Lubricate the elbow joint with grease.

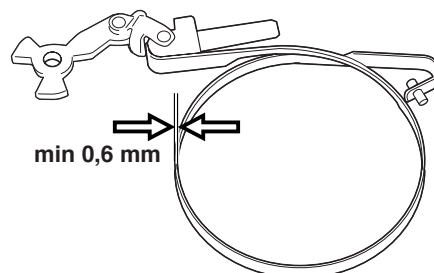

## Chain brake – reassembly

1

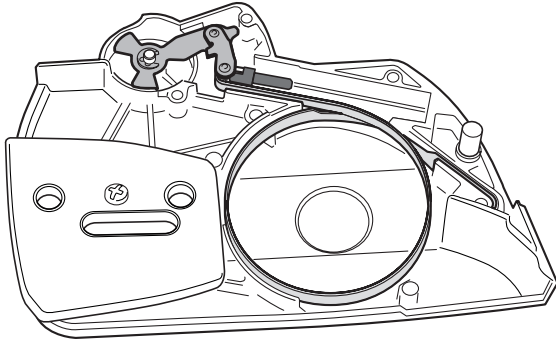

Bolt the elbow joint to the brake band and tighten to a torque of 1–1.5 Nm.  
Locate the elbow joint and connected brake band in their recesses in the clutch cover. Lubricate the recess for the spring with grease.

2



**WARNING!**  
Make sure the spring does not fly out and cause injury. Wear eye protection.

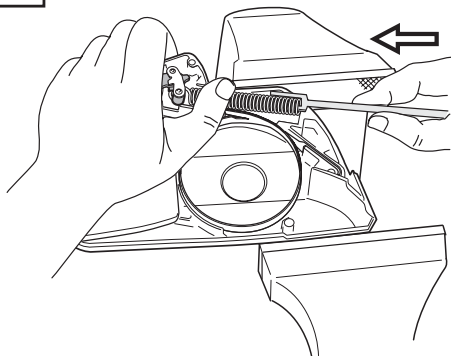

Grip the clutch cover in a vice. Compress the spring with special tool 502 50 67-01 and push it down with your thumb.

3

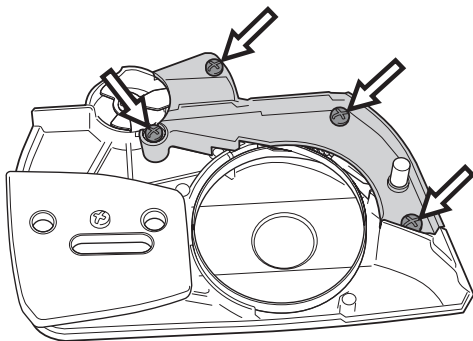

Fit the cover over the chain brake spring, tightening the screws to a torque of 1–1.5 Nm.

4

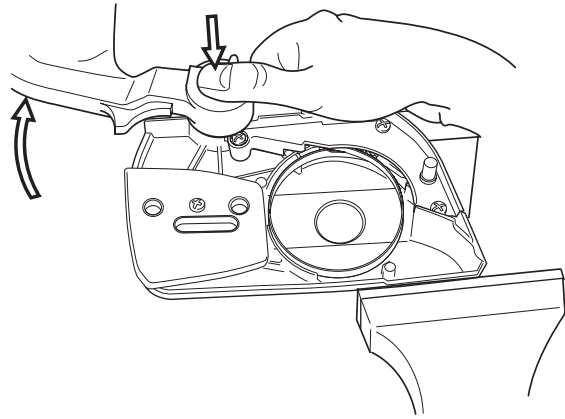

Tension the brake spring by using the kickback guard from the saw as a tool. Engage it with the brake mechanism and turn clockwise to release the brake.

5

Turn the chain tensioner anticlockwise as far as it will go.

Refit:

- guide bar
- chain
- clutch cover

### NOTE!

After completing the repair the chain brake must be tested as described below.

### Operating test:

The engine must not be running during the test.

Guide bar length	Height
38cm/15"	50 cm/20"

- Hold the chainsaw over a firm surface. The height of the guide bar above the surface is given in the table above.
- Let go of the front handle and let the chainsaw fall towards the surface.
- When the guide bar hits the surface the chain brake must engage.

## Silencer – removal



**WARNING!**  
Do not touch the silencer until it has cooled down, otherwise you may burn yourself.

1

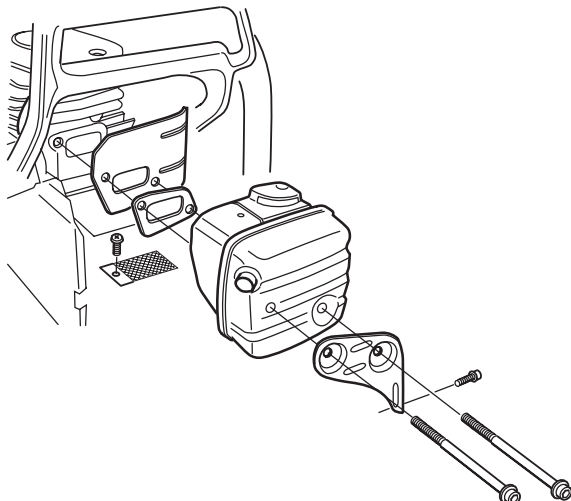

Remove the cylinder cover, silencer support, silencer, gasket and cooling plate.

2

If the saw is fitted with a spark arrestor mesh this must also be removed.

## Cleaning and inspection

Clean and inspect all parts carefully. If there are any cracks or other defects replace the damaged parts with new ones.

The spark arrestor mesh is best cleaned with a wire brush. If the mesh is damaged it must be replaced.

If the mesh is blocked the saw will overheat and this will cause damage to cylinder and piston.

Never use the saw with a silencer that is in poor condition. Always use original parts.

## Silencer – refitting

1

If the saw is equipped with a spark arrestor mesh this should be fitted first.

2

Refit

- cooling plate
- gasket
- silencer, tighten bolts to a torque of 8–10 Nm.
- silencer support
- cylinder cover

3

Run the saw for at least 1 minute, then retighten the silencer bolts to 8–10 Nm.

## Chain catcher – replacement

If the chain catcher is worn it must be replaced with a new one.

1

Release the brake by pushing the kickback guard backwards. Undo the guide bar bolts and remove the clutch cover, chain and guide bar.

2

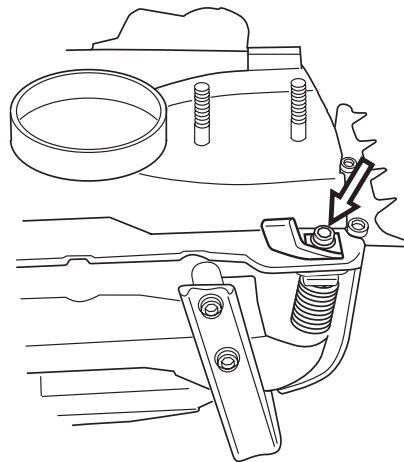

Remove the chain catcher and replace it with a new one. Check that the vibration damping spring locates correctly against the crankcase when you bolt the new chain catcher in position.

A worn (damaged) chain catcher on 340, 345 or 350 can be replaced with the same chain catcher as 346XP, 351 and 353 (see figure above).

3

Turn the chain tensioner anticlockwise as far as it will go.

Refit:

- guide bar
- chain
- clutch cover

## Stop switch – removal

1  
Remove the cylinder cover and air filter.

2

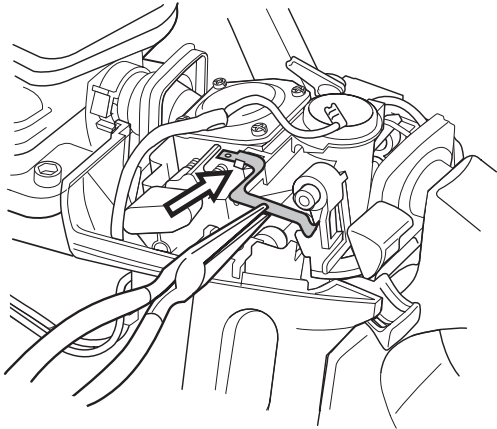

Disconnect both leads from the stop plate and stop switch. Remove the stop plate by carefully sliding it over the lug on the front mounting.

3

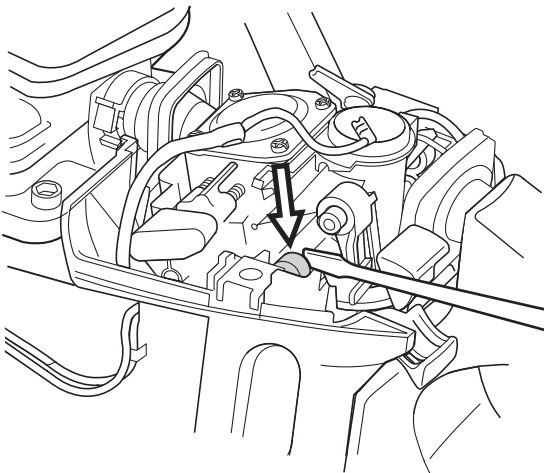

Carefully prise the carburettor assembly off the left-hand rubber mounting using a small screwdriver.

4

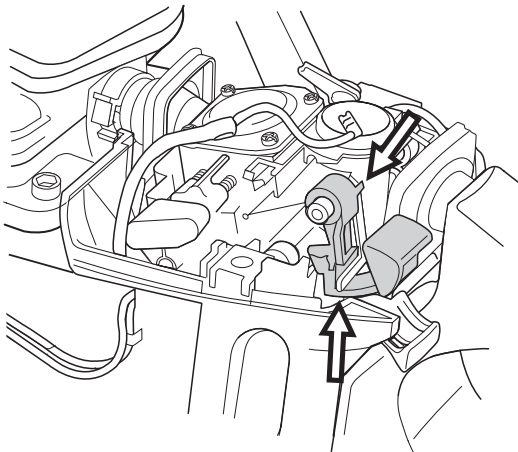

Carefully prise the stop switch's upper mounting off the air filter holder while lifting the switch to release it from the lower mounting.

## Cleaning and inspection

Clean and inspect all parts carefully. If there are any cracks or other defects replace the damaged parts with new ones. Always use original parts.

## Stop switch – resistance measurement

Clean the mating surfaces and check the resistance as follows:

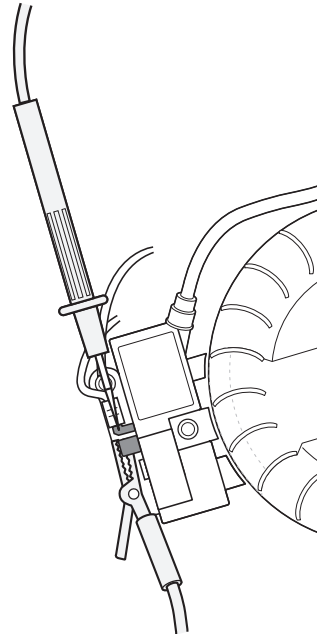

Measure the resistance by connecting a multimeter to the ignition coil. NOTE! The switch must be in the "on" position to give the correct reading.

The resistance must not be higher than 0.2 ohm when the switch is in the on position.



## Stop switch – refitting

1

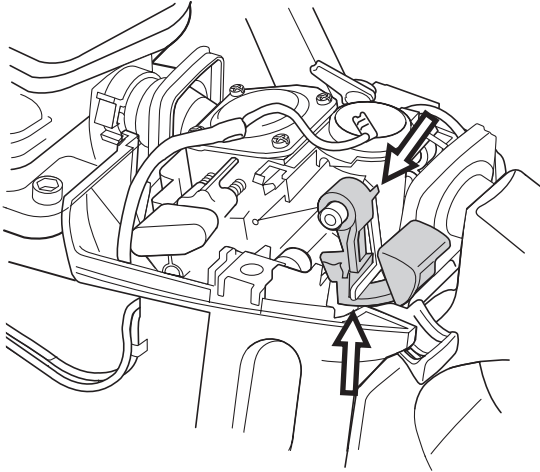

Carefully press the new stop switch into place. Check that the switch's upper mounting clips over the air filter holder.

2

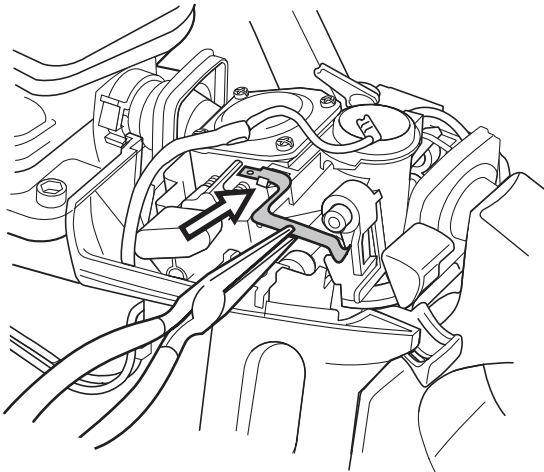

Refit the stop plate. Engage the stop plate in the front slot first then lift the rear edge onto the stop switch. Slide the stop plate in as far as it will go.

3

Refit:

- the leads to the stop plate and stop switch
- air filter
- cylinder

## Choke control – removal

1

Remove the cylinder cover, air filter and stop switch. Disconnect the fuel hose from the carburettor.

### NOTE!

Do not use knurled pliers to disconnect or reconnect the fuel hose. This could damage the hose and lead to leakage or fracture.

2

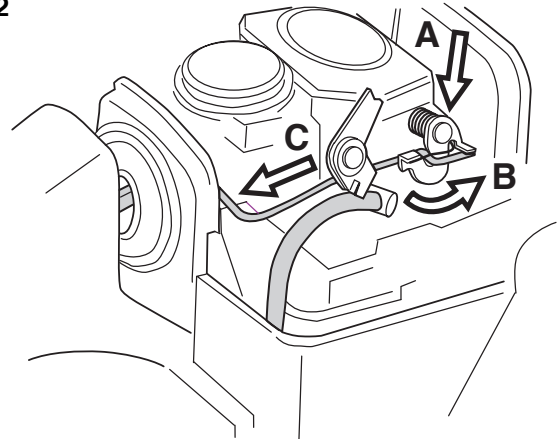

Disconnect the pushrod from the carburettor by first carefully prising up the spring over the end of the rod, where it connects to the throttle lever (A). Then press the throttle lever forwards (B) while pressing the throttle pushrod backwards (C) and lifting it off the lever. Withdraw the throttle pushrod from the tank and lift it upwards without pulling it through the rubber inlet manifold. Carefully release the carburettor assembly from the right-hand rubber mounting and lift it upwards.

3

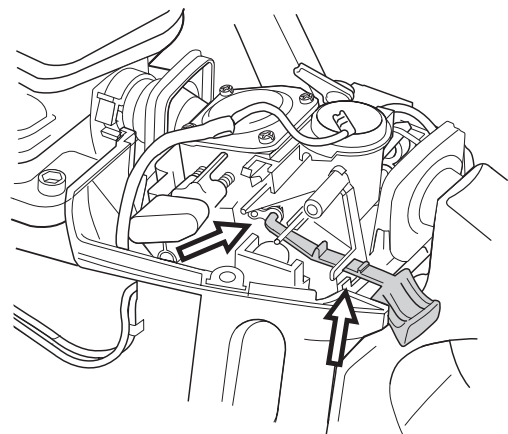

Compress the clip that holds the choke control to the carburettor while pulling it out at the same time. Disconnect the choke control from the air filter holder.

## Choke control – refitting

First reattach the choke control to the air filter, then press it onto the carburettor so that the clips engage.

Then refit:

- stop switch
- carburettor into its rubber mountings
- throttle pushrod into the fuel tank and connect to throttle lever.
- lift the spring arm over the throttle pushrod
- fuel hose to the carburettor
- air filter and cylinder cover

## Throttle lock, throttle trigger and return spring – removal

1

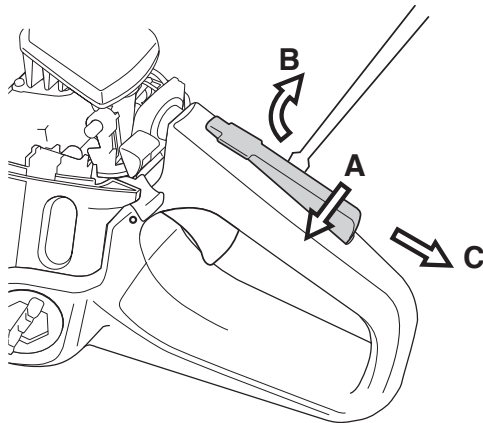

Remove the throttle lock by pressing it to the left (A) and carefully levering it up with a screwdriver on the clutch side (B) of the saw to disengage the lugs on either side of the throttle lock from the fuel tank. When both lugs are clear of the tank, pull the lock backwards (C).

2

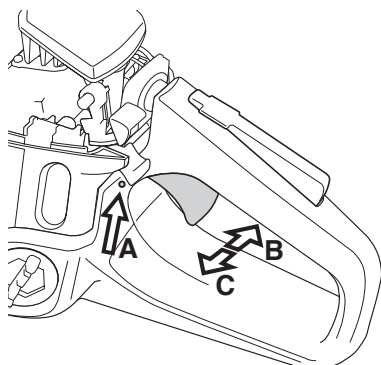

Drive out the steel pin using a 2.5 mm/0.1" diameter drift (A). Push it out from the flywheel side of the saw. Remove the throttle trigger by first pressing it towards the clutch side of the saw (B) until it clicks, then towards the flywheel side until it clicks again. Remove it from the tank and lift out the return spring.

## Cleaning and inspection

- Clean and inspect all parts carefully. If there are any cracks or other defects replace the damaged parts with new ones. Always use original parts.
- Lubricate the throttle lock with oil.
- Check that the spring is not broken and has not lost its tension.

## Throttle lock, throttle trigger and return spring – refitting

1

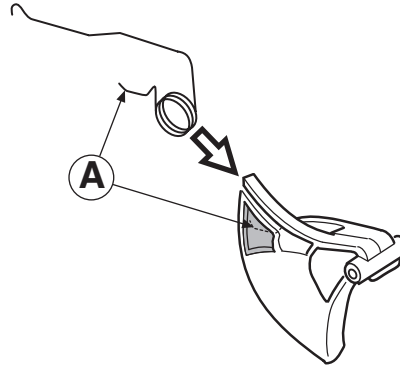

Refit the return spring to the throttle trigger as shown. Make sure the spring is correctly positioned by engaging one end in the slot in the throttle trigger (A).

2

First insert the rear edge of the throttle trigger into the tank. Then push/clip the front edge into the two clips on the tank with the aid of a combination tool, for example. Drive in the steel pin from the clutch side. Use a 2.5 mm/0.1" diameter drift.

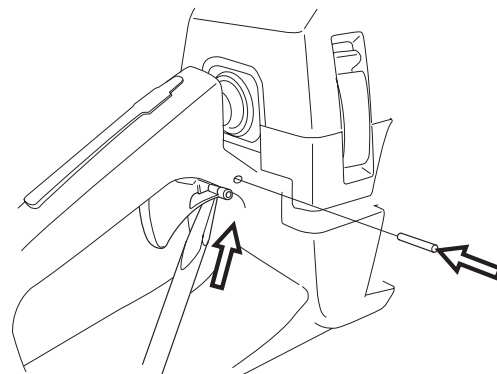

3

Then press down the return spring while pressing the throttle lock forwards/upwards into the retaining clip in the fuel tank until you hear a click. Release the return spring in the throttle lock, then press the lock down onto the tank.

4

Check the operation of the throttle lock by trying to press the throttle trigger without pressing down the throttle lock. Also check that the throttle lock and throttle trigger return freely to their original positions when released.

## Hand grip heater on model 346XPG, 351G, 353G – removal

No heating or heating only in front hand grip

### • Front hand grip – troubleshooting

1

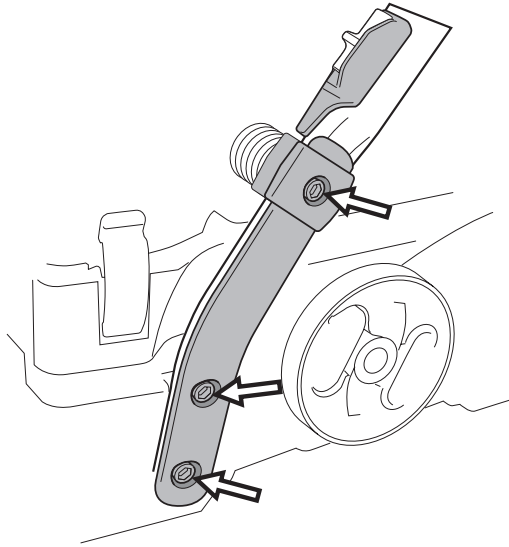

Remove the three bolts that secure the cover over the front hand grip. Disconnect the leads from the switch and generator and measure the resistance of the hand grip heater, which should be 3–4 ohm. Replace the front hand grip if the resistance is higher.

2

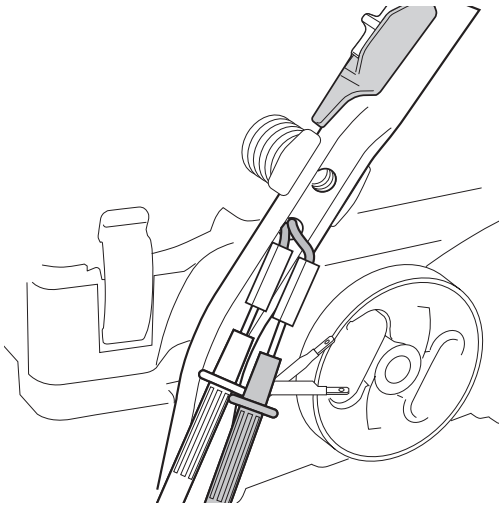

Reconnect the leads and refit the cover.

3

Push the switch back into place and reconnect the leads.

4

Bolt the cover back onto the hand grip.

### • Generator – troubleshooting

1

Remove the cylinder cover and cover from the front hand grip. Disconnect the black lead from the generator and connect a multimeter between it and a clean area on the cylinder. The multimeter should show a resistance of 0.9–1.3 ohm. If the reading is higher or lower, replace the generator, see “Replacing the generator”.

2

Reconnect the lead and refit the hand grip cover and cylinder cover.

### • Switch – troubleshooting

1

Carefully free the switch and frame from the front hand grip using a screwdriver.

2

Disconnect the leads from the switch and connect a multimeter to it. The meter should read over 1000 ohm when the switch is in the “0” position. The meter should read no higher than 0.1 ohm with the switch in the “1” position. Replace the meter if the readings are outside these limits.

### Rear hand grip heater not working

#### • Rear hand grip heater – troubleshooting

1

Remove the cylinder cover, air filter and cover from the rear hand grip.

2

Disconnect the red lead from the heater and connect a multimeter between it and the black earth lead that is bolted to the bottom of the carburettor on the clutch side of the saw. The meter should read 0.7–1.2 ohm. If the reading is higher replace the heater element.

3

Remove the air filter, throttle pushrod, rubber diaphragm and carburettor, see “Carburettor – removal”.

4

Remove the bolt from the plate at the base of the carburettor to release the lead for the heater element.

5

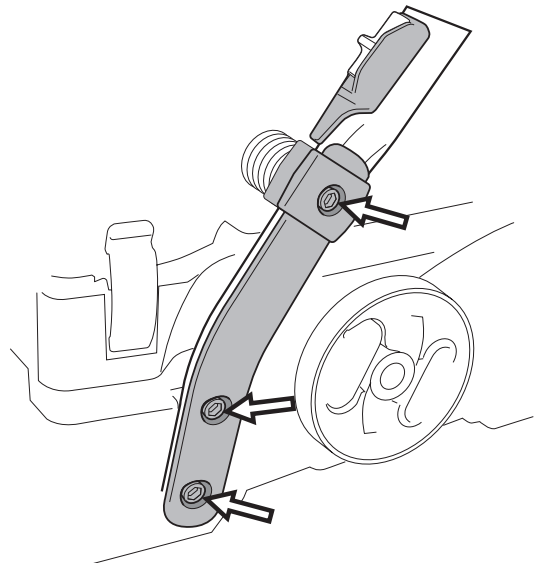

Unscrew the three bolts from the front hand grip and remove the cover to reveal the leads. Disconnect the red lead.

6

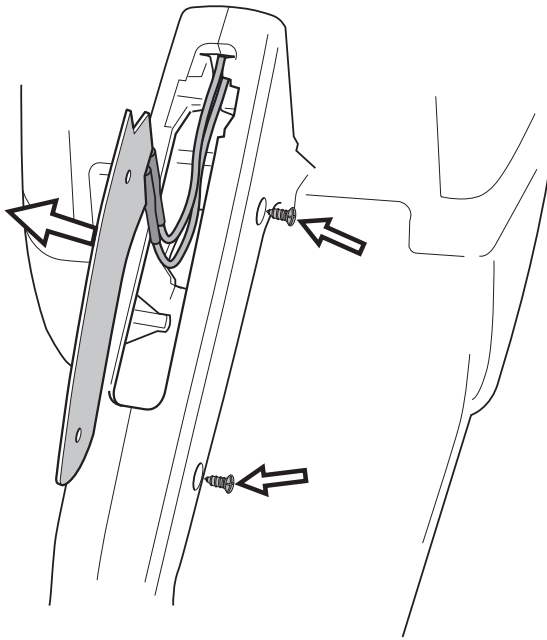

Unscrew the two bolts from the right side of the rear hand grip. Remove the throttle lock and throttle handle, see "Throttle trigger". Pull out the heater element with the leads still connected.

### Troubleshooting carburettor heater (346XPG, 351G, 353G)

#### Operation

The carburettor temperature is controlled by an electronic thermostat to eliminate the risk of ice formation in the carburettor. The thermostat switches on/off at 12°C/54F. This means that the saw operator does not need to remember to switch the carburettor heater on or off.

#### • Troubleshooting

##### Front handle heater

Remove the side cover from the handle. Disconnect the leads at F and G (see diagram). Clean the connectors. Turn the switch "on". Measure the resistance between F and G. The reading should be  $4 \pm 1$  ohms. If not, disconnect the lead at O and remove the switch. Measure the resistance between O and F. The reading should be  $4 \pm 1$  ohms. If the resistance is incorrect, replace the front handle. Disconnect the lead at N and G and measure the resistance between these points. The reading should be no higher than 0.1 ohm. If it is too high, replace the lead.

##### Switch

Measure the resistance between N and O with the switch turned off. The reading should be 1 000 ohms or higher. Repeat the measurement with the switch turned on. The reading should be no higher than 0.1 ohm. If it is too high, replace the switch.

##### Rear handle heater

Measure the resistance between F and Z. It should be  $1 \pm 0.5$  ohm.

If not, replace the rear handle heater.

##### Generator

Measure the resistance between G and H. It should be between 0.3–1.3 ohm.

If not, replace the generator.

##### Carburettor heater

Disconnect the lead at X and clean the connectors. Measure the resistance between X and G.

The reading should be between 3–10 ohms. If not, disconnect the lead at Y and clean the connectors.

Measure the resistance between X and Y, if the reading is not between 3–7 ohms – replace the carburettor heater.

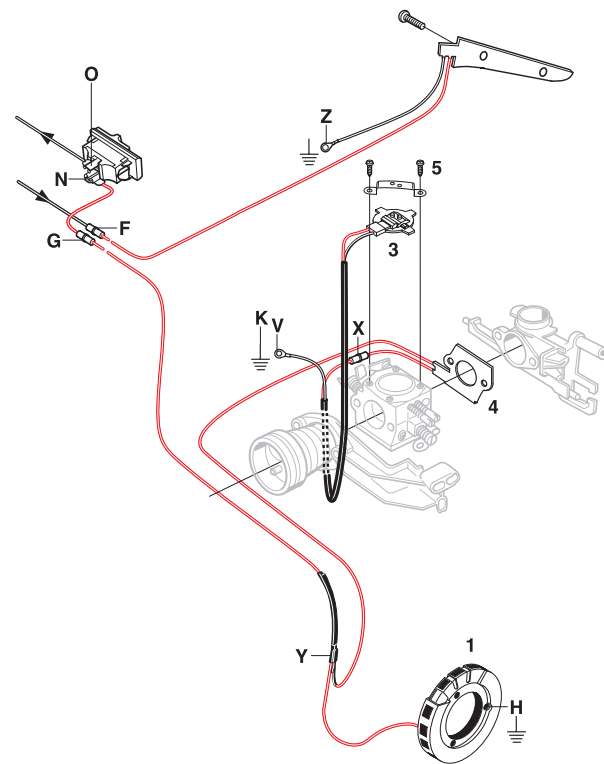

## Heater element and rear hand grip – removal

1

Remove the cylinder cover, hand grip cover, hand grip and right-hand stop.

Then remove:

- throttle lock, throttle trigger and recoil spring, see “Throttle trigger”.
- fuel hose and throttle pushrod from the carburettor

Unbolt the rear tank mounting from the crankcase, i.e. the rear vibration damping spring, and both stops. Lower the tank as far as it will go to allow access to the heater lead where it is connected to the tank.

Refit:

- fuel tank with both stops and the rear vibration damping spring
- throttle lock, throttle trigger and recoil spring, see “Throttle trigger”.
- fuel hose and throttle pushrod to the carburettor (check that the hose is not trapped between the tank and crankcase, measurement 43 mm/1.69 inches)
- hand grip cover, air filter and cylinder cover

## Heater element and rear hand grip – removal

1

Screw the heater element into place using the two screws and feed the leads through the rear hand grip. Secure the red lead in the clip on the tank and connect it. Feed the black lead through crankcase and secure/earth it to the base of the carburettor using the bolt at the front on the clutch side of the saw. Tighten to a torque of 3–4 Nm.

2

Refit:

- fuel tank with both stops and the rear vibration damping spring
- throttle lock, throttle trigger and recoil spring, see “Throttle trigger”.
- fuel hose and throttle pushrod to the carburettor (check that the hose is not trapped between the tank and crankcase, measurement 43 mm/1.69 inches)
- hand grip cover, air filter and cylinder cover

## Hand grip heater on model 346XPG, 351G, 353G – refitting

1

Feed the leads into the rear hand grip and insert the heater element in the hand grip. Screw in the two bolts through the right side of the hand grip to secure the heater.

2

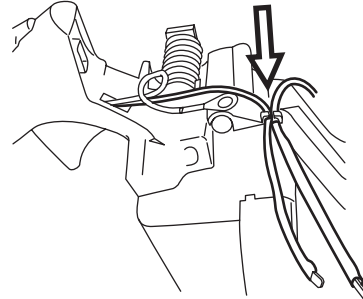

Press the black lead into the base of the carburettor and connect it with the bolt. Tighten to a torque of 3–4 Nm.

3

Run the red lead to the front hand grip and connect it.

4

Press the throttle trigger and throttle lock into position and check that they work correctly, see “Throttle trigger”.

5

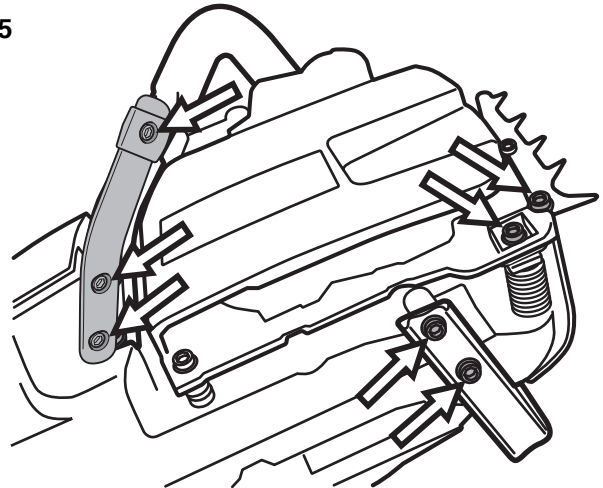

Bolt the vibration damping springs that hold the tank unit back in place and refit the cover over the front hand grip.



## Starter assembly – removal

1

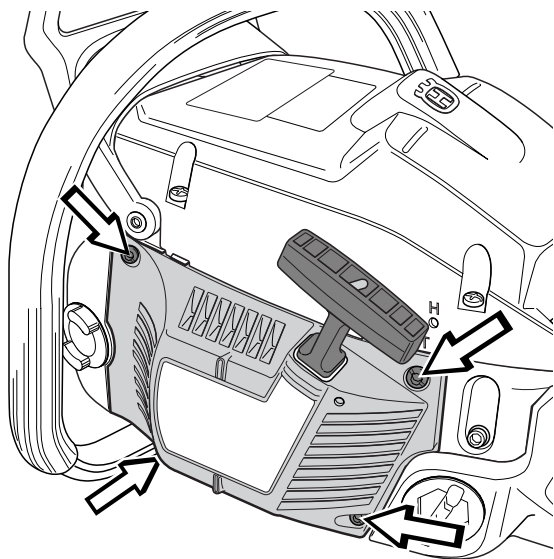

Undo the four bolts that fasten the starter assembly to the crankcase and lift off the starter assembly.

2

Pull out about 30 cm of the cord and fasten it in the notch in the pulley rim. Release the tension in the return spring by letting the pulley wind backwards slowly.

3



**WARNING!**  
If the recoil spring is still under tension when the pulley is removed it can fly out and cause injury. Wear eye protection.



Remove the bolt from the centre of the pulley and lift off the pulley.

## Cleaning and inspection

Clean the parts and check the following:

- The starter cord.
- The teeth on the pulley, lubricate with oil.
- That the pawls on the flywheel are undamaged, i.e. that they spring back towards the centre and move freely.
- Lubricate the return spring with light oil.

## Replacing a broken or worn starter cord

1

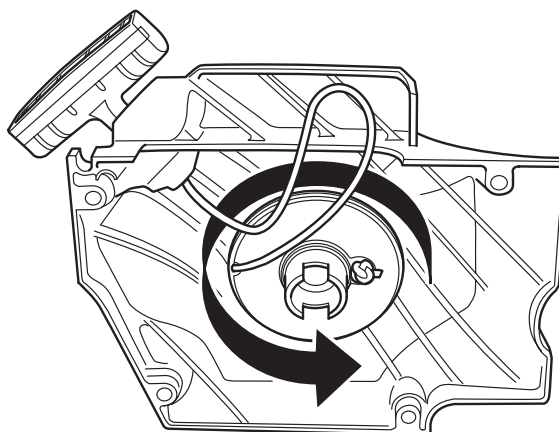

Before replacing a worn starter cord the tension in the recoil spring must be released. Pull the starter cord out through the notch in the pulley rim and wind the pulley anti-clockwise to release the tension in the spring.

2

Remove the bolt from the centre of the pulley and lift off the pulley.

3

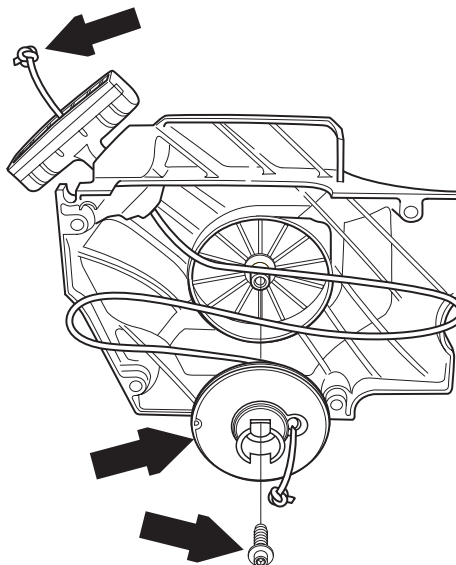

Fit a new cord through the hole in the pulley and tie a knot to secure it. Feed the other end of the cord through the hole in the starter housing and through the starter handle, then tie a double knot in the end. Wind about 3 turns of the starter cord onto the pulley. Fit the bolt through the centre of the pulley and tighten to a torque of 2–3 Nm.

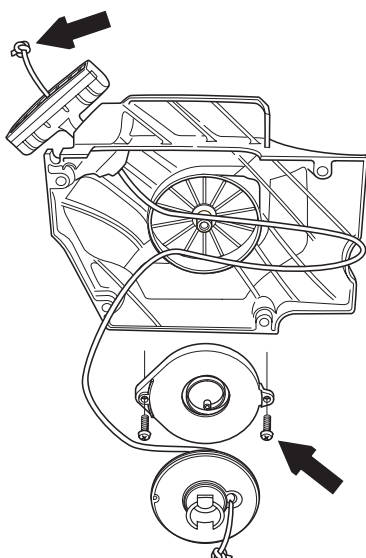

Cleaning and inspection:

- Clean and inspect all parts carefully. If there are any cracks or other defects replace the damaged parts with new ones. Lubricate the return spring with light oil.

### Tensioning the recoil spring

1

Fasten the starter cord in the notch in the pulley rim and wind the pulley about 2 turns clockwise. Check that the pulley is free to rotate at least another half turn when the starter cord is fully extended.

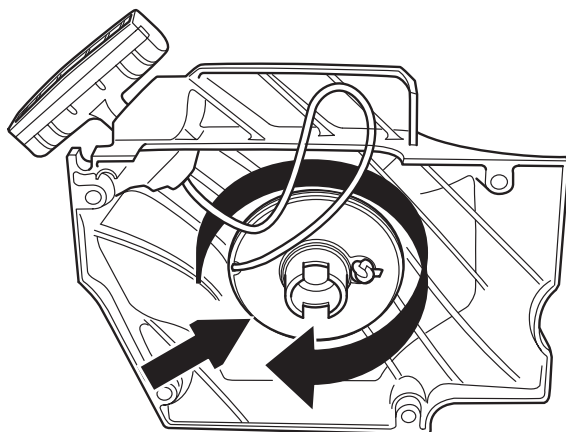

### Replacing a worn recoil spring



**WARNING!**  
Make sure the recoil spring does not fly out and cause injury. Wear eye protection.



1

Remove the bolt from the centre of the pulley and lift off the pulley and spring.

2

Remove the broken recoil spring.

3

Fit the bolt through the centre of the pulley and tighten to a torque of 2–3 Nm.

Tension the recoil spring, see “Tensioning the recoil spring”.

### Starter assembly – refitting

1

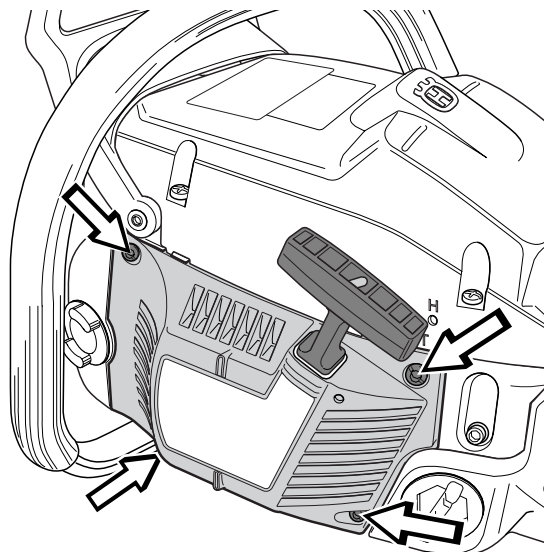

Position the starter assembly on the crankcase and tighten the bolts to a torque of 2.5–3.5 Nm.

## Ignition module – testing

If there is a fault in the ignition system the ignition module must be tested before the ignition system is removed.

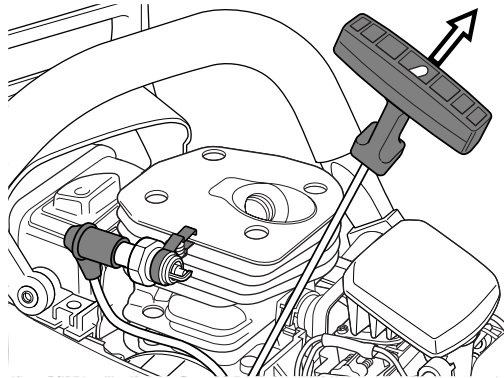

Test the ignition module as follows:

- Connect a test spark plug 502 71 13-01 to the ignition lead and clip the test spark plug onto the cylinder.
- Turn the engine over using the starter cord.
- If the test spark plug produces a spark the ignition module is OK.

## Ignition module/flywheel – removal

1

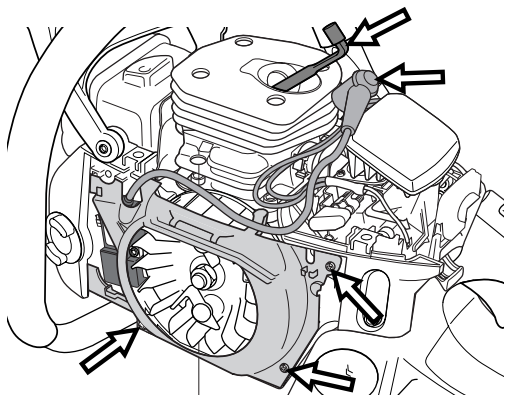

Remove the cylinder cover. Disconnect the HT lead, remove the spark plug and fit piston stop 502 54 15-01 in its place. Take off the starter assembly, release the leads from the cable guide and remove it.

### Model 346XP, 351, 353:

Remove the cover from the hand grip.

2

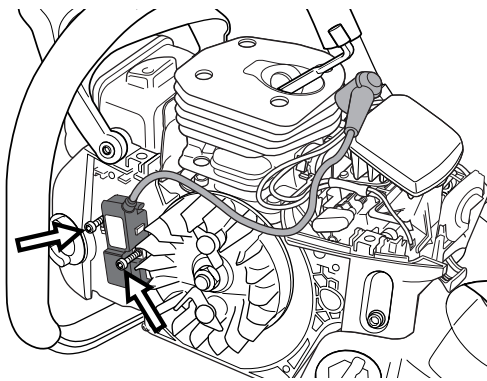

If replacing the ignition module, disconnect its leads and unscrew it. The ignition module can be left in place if you are simply removing the flywheel.

3

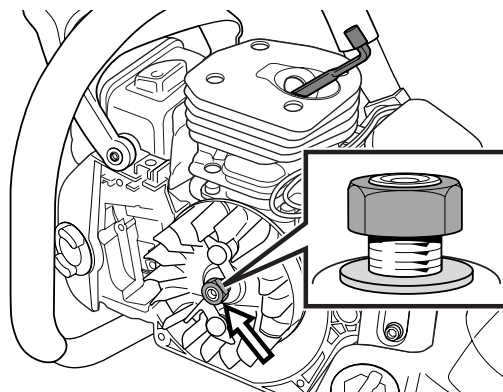

Loosen the flywheel nut using a suitable socket and unscrew it until it is flush with the end of the shaft.

4

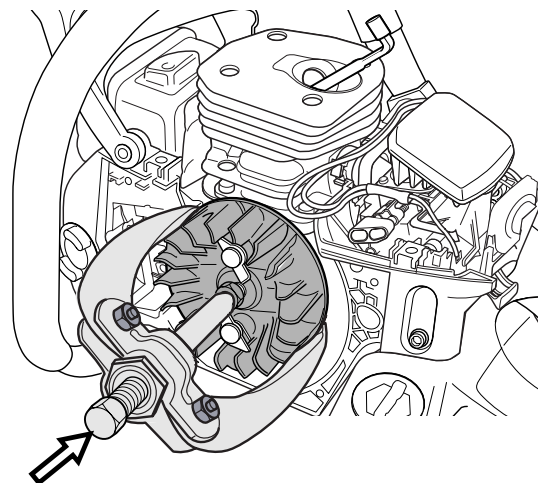

Position puller 504 90 90-02 over the magnets and counterweight on the flywheel. Tighten 2–3 turns and tap the head of the puller with a metal mallet to release the flywheel. Remove the puller, nut and washer. Lift off the flywheel.

## Cleaning and inspection

- Clean all parts, especially the tapers on the flywheel and shaft.
- Check that the flywheel is not cracked or damaged in any other way.



## Replacing the generator, model 346XP, 351, 353

1

Remove the cylinder cover. Disconnect the HT lead, remove the spark plug and fit piston stop 502 54 15-01 in its place. Take off the starter assembly, release the leads from the cable guide and remove it. Remove the cover from the hand grip.

2

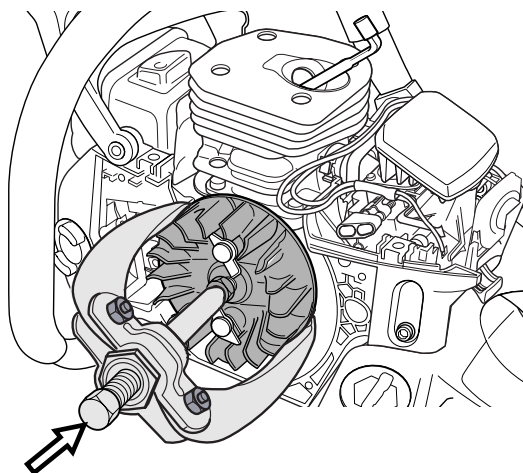

Loosen the flywheel nut using a suitable socket and unscrew it until it is flush with the end of the shaft.

Position puller 504 90 90-02 over the magnets and counterweight on the flywheel. Tighten 2–3 turns and tap the head of the puller with a metal mallet to release the flywheel. Remove the puller, nut and washer. Lift off the flywheel.

3

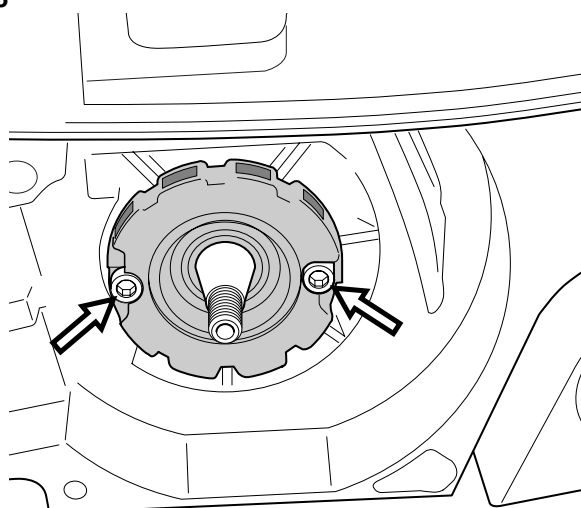

Unscrew the two bolts from the generator but leave the generator in place.

4

Remove the fuel hose and throttle pushrod from the carburettor.

Unbolt the rear tank mounting from the crankcase, i.e. the rear vibration damping spring, and both stops. Lower the tank as far as it will go to allow access to the heater lead where it is connected to the tank.

5

Disconnect the generator lead from the hand grip and unclip it from the tank. Remove the generator and lead.

### Generator – refitting

1

Feed the generator lead through the holes in the crankcase and hand grip. Bolt the generator in position, tightening the bolts to a torque of 5 Nm. Clip the lead to the tank.

**NOTE!** The lead connector must be positioned on the right of the clip, see diagram. Connect the lead to the connector on the hand grip.

2

Refit:

- fuel tank with both stops and rear vibration damping spring
- fuel hose to carburettor, hose length between tank and crankcase: 43 mm/1.69 inches and between crankcase and carburettor: 53 mm/2.09 inches
- throttle pushrod to carburettor
- flywheel with nut and washer
- cable guide, leads and starter assembly

Remove the piston stop and reconnect the HT lead and cylinder cover.

## Ignition module and flywheel – refitting

1

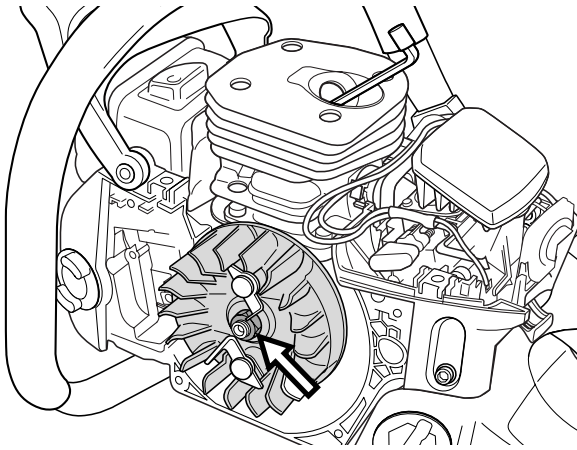

Place the flywheel on the crankshaft. Turn the flywheel so that the key lines up with the keyway in the shaft.

Fit the washer and nut on the shaft and tighten to a torque of 25-30 Nm.

2

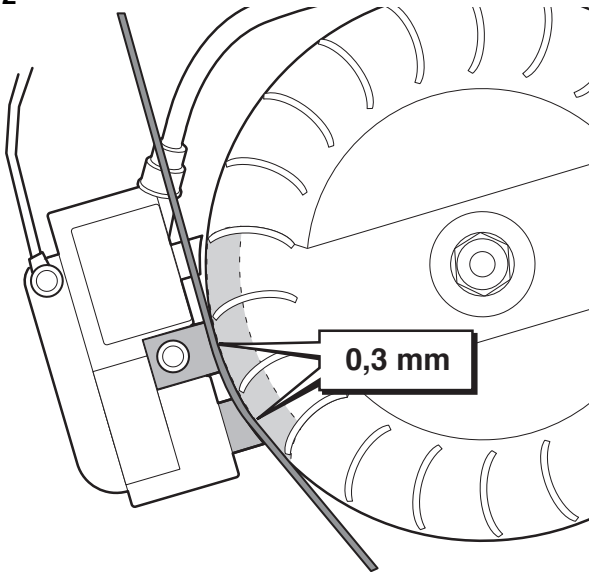

To refit the ignition module proceed as follows:

Turn the flywheel so that the magnets are in line with the ignition module. Fit the ignition module with the plastic feeler gauge (502 51 34-01) held in position at the same time, without tightening the bolts. Connect the black earth lead to the front screw on the ignition module. Adjust the gap between the ignition module and magnet to 0.3 +/- 0.1 mm. The gap must be measured at either of the two lowest pegs on the ignition module. Tighten the bolts to 4.5–6 Nm. Connect the blue lead to the ignition module.

3

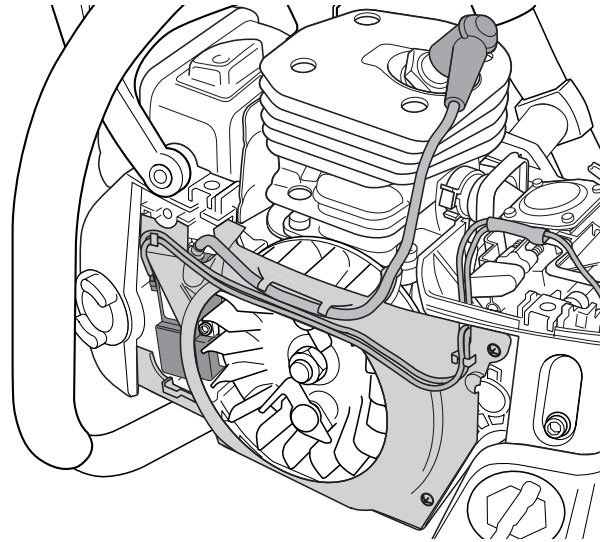

Then refit:

- cable guide and press the leads into position
- HT lead
- starter assembly, tighten to a torque of 2.5–3.5 Nm
- cylinder cover

## Centrifugal clutch – removal

1

Remove the cylinder cover. Disengage the chain brake by pushing the kickback guard backwards. Undo the guide bar bolts and remove the clutch cover, chain and guide bar.

2

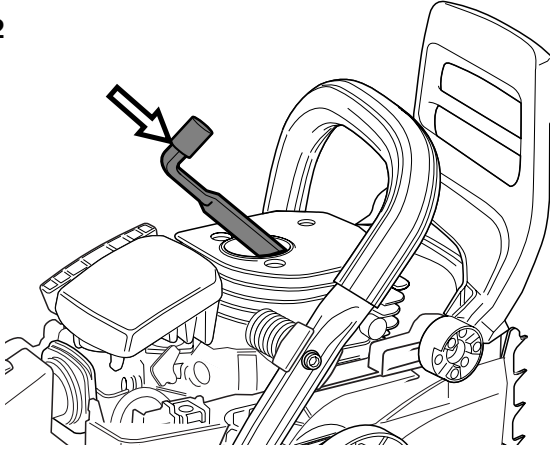

Disconnect the HT lead. Remove the spark plug and fit piston stop 502 54 15-01 in its place.

3

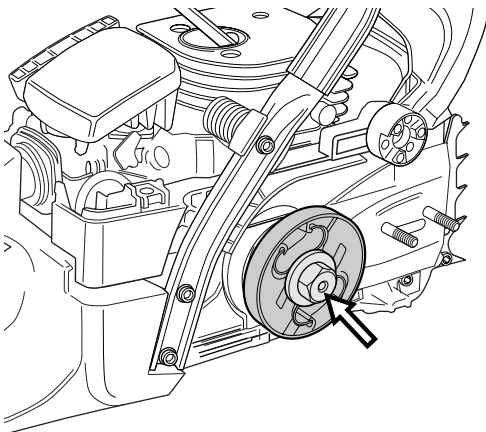

Unbolt the clutch using tool 502 54 16-01 and a suitable socket or combination spanner. Turn the nut clockwise to remove it.

4

### NOTE!

Handle the clutch springs carefully. If they are opened up too much they could damage the saw.

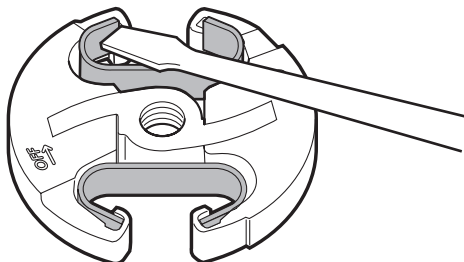

Carefully prise out the clutch springs with a screwdriver.

## Inspection and cleaning

- Clean and inspect all parts carefully. If there are any cracks or other defects replace the damaged parts with new ones. Always use original parts.

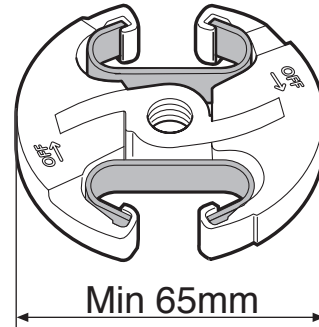

- Check the thickness of the clutch shoes by using vernier callipers to measure the diameter of the clutch. If the diameter is less than 65 mm the clutch assembly must be replaced.

## Centrifugal clutch – refitting

1

### NOTE!

Handle the clutch springs carefully. If they are opened up too much they could damage the saw.

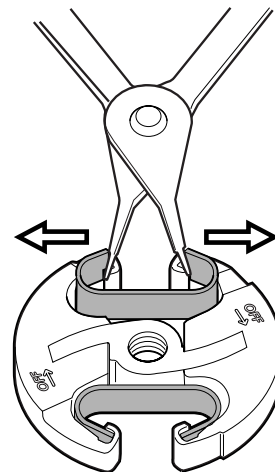

Insert the clutch springs in the shoes using circlip pliers.

2

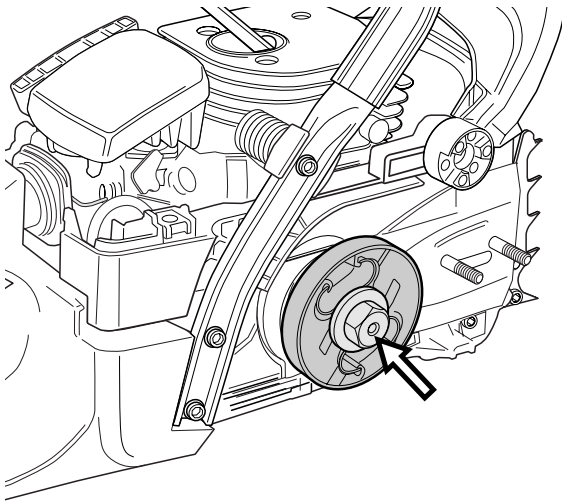

Fit the clutch onto the crankshaft and tighten anticlockwise as far as it will go. Then tighten to a torque of at least 20 Nm using tool 502 54 16-01 and a suitable socket or combination spanner.

3

Remove the piston stop. Fit the spark plug, tightening it to a torque of 15 Nm, then connect the HT lead.

Then refit:

- cylinder cover
- guide bar
- chain
- clutch cover

### Oil pump – removal 346XP, 350, 351, 353

1

Empty and clean the oil tank.

2

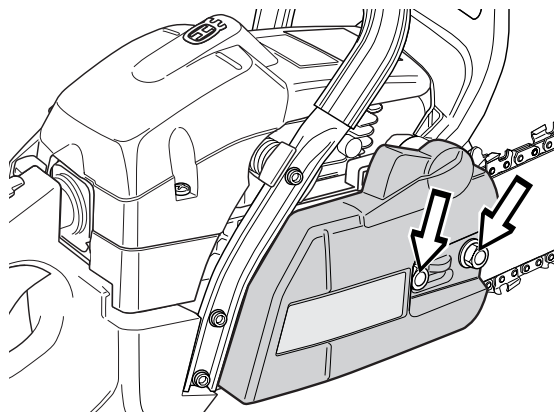

Remove the cylinder cover. Disengage the chain brake by pushing the kickback guard backwards. Undo the guide bar bolts and remove the clutch cover, chain and guide bar. Disconnect the HT lead. Remove the spark plug and fit piston stop 502 54 15-01 in its place. Unscrew the clutch (clockwise) using clutch tool 502 54 16-01 and a suitable socket spanner or combination spanner.

3

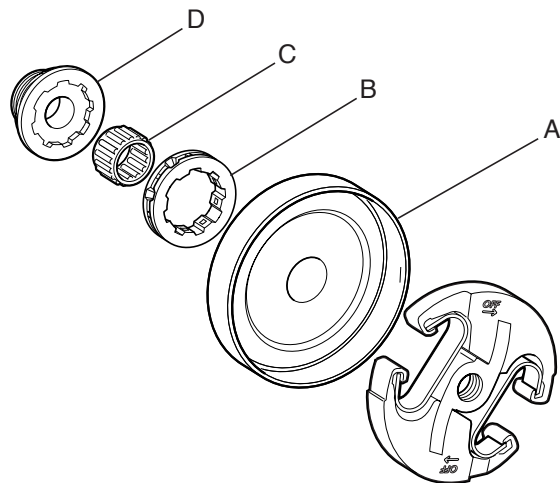

Unbolt and remove the clutch drum (A), RIM chain sprocket (B) if fitted, needle bearing (C) and pump drive wheel (D).

#### Model 350:

Remove the bolts on the anti-vibration elements on the same side.

4

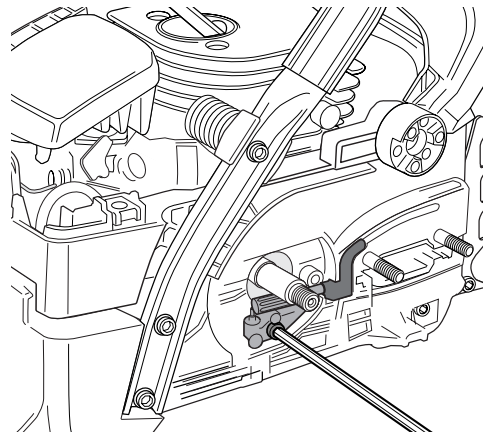

Unbolt the oil pump from the crankcase.

5

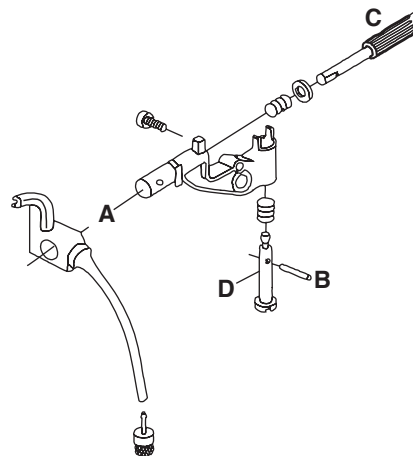

Remove the oil hose and filter (A).

#### Model 350:

Push the housing up a little from the fuel tank and remove the filter (A) from underneath, see the diagram under “Oil pump – removal 340, 345”.

**6**  
Remove the pin (B) from the adjuster screw, using a small drift to press it out.

**7**  
Press in the pump piston (C) so that the adjuster screw (D) can be removed. Remove the pump piston.

### Oil pump – removal 340, 345

**1-4**  
See "Oil pump – removal, models 346XP, 350, 351, 353", points 1-4.  
Remove the bolts on the anti-vibration elements on the same side.

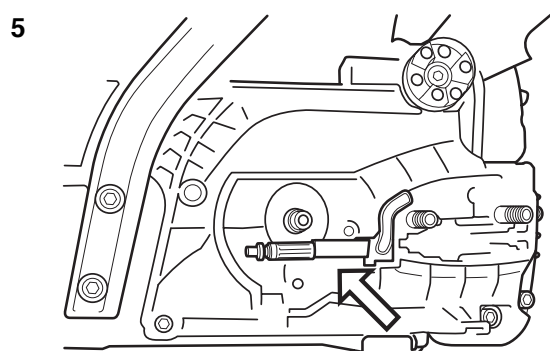

Carefully lift out the oil pump from the crankcase.

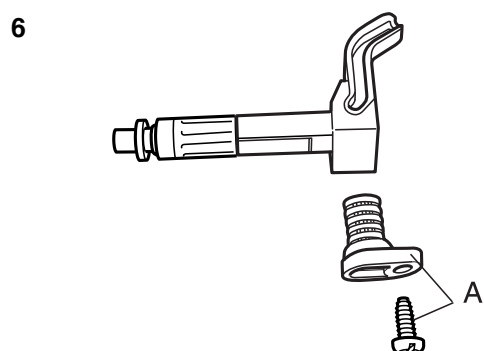

Push the crankcase up a little from the fuel tank and remove the filter (A) from underneath.

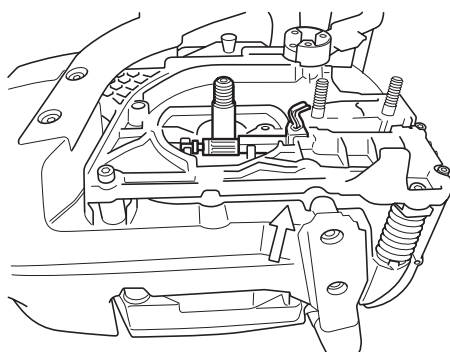

### Cleaning and inspection

- Clean and inspect all parts carefully. If there are any cracks or other defects replace the damaged parts with new ones. Always use original parts.
- Lubricate all moving parts with chain oil.

### Oil pump –refitting 346XP, 350, 351, 353

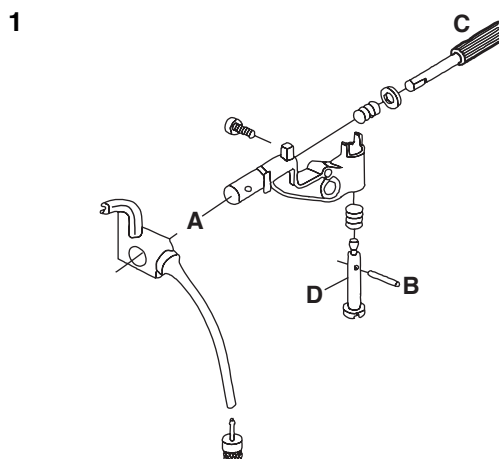

Lubricate the pump piston (C) with chain oil and fit the pump piston and washers.

**2**  
Press down the pump piston (C). Fit the adjuster screw and spring so that the pin (B) can be pressed into position.

**3**  
Reconnect the oil hose and filter (A).

#### Model 350:

Push the crankcase up a little from the fuel tank and screw on the filter (A) from underneath.



#### WARNING!

Poor chain lubrication can result in failure of the chain, which could cause serious or fatal injury.

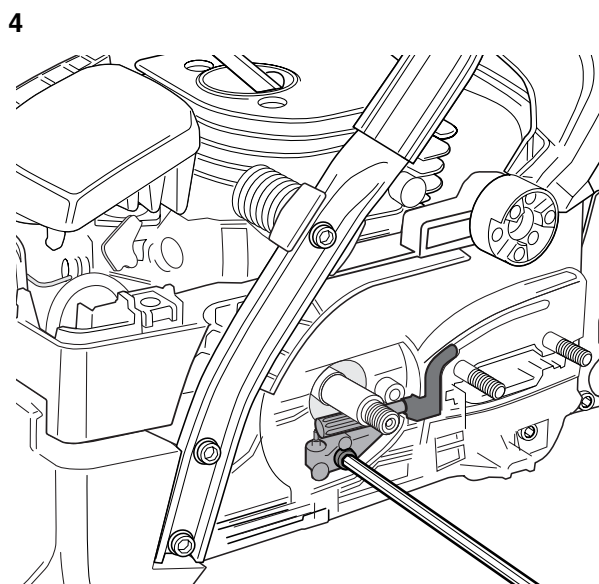

Bolt the oil pump to the crankcase. The adjustable oil pump must be bolted to torque of 2–3 Nm.



5

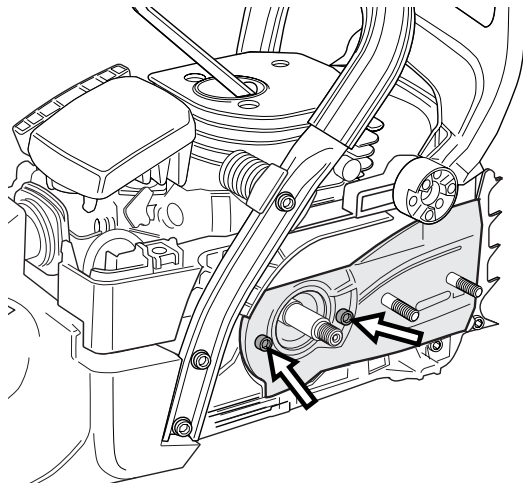

Fit the chain guard plate, tightening the bolts to a torque of 2–3 Nm.

**Model 350:**

Fit the bolts on the anti-vibration elements on the same side.

6

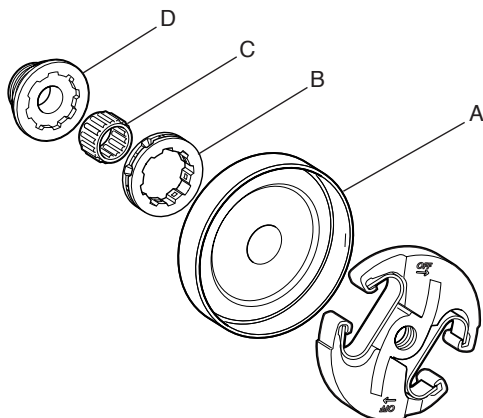

Lubricate the needle bearing with grease. Fit the pump drive wheel (D), needle bearing (C), chain sprocket (B), if fitted, and clutch drum (A).

7

Fit the clutch onto the crankshaft and tighten anticlockwise as far as it will go. Then tighten to a torque of at least 20 Nm using tool 502 54 16-01 and a suitable socket spanner or combination spanner.

8

Remove the piston stop. Fit the spark plug, tightening it to a torque of 15 Nm, then connect the HT lead. Then refit the cylinder cover, guide bar, chain and clutch cover.

9

Refill the tank with oil. For more information see the user instructions for this model for the recommended grade of oil.

**Oil pump –refitting 340, 345**

1

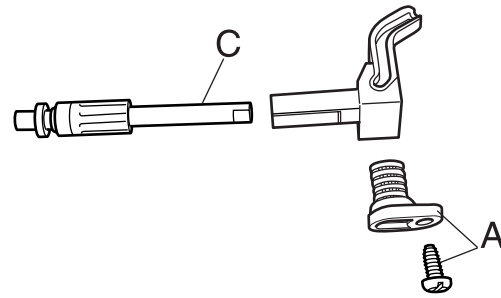

Lubricate the piston pump (C) with chain oil and fit the pump piston.

2

Fit the pump. A round pin secures its position.

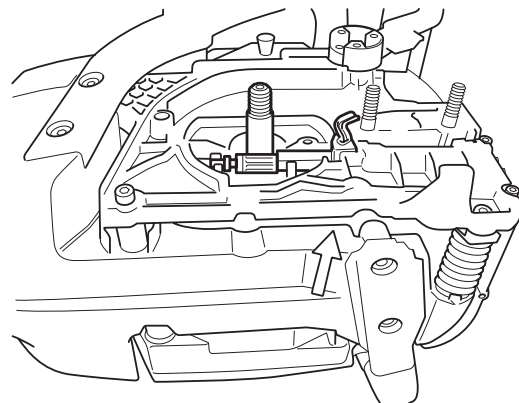

Push the crankcase up a little from the fuel tank and screw on the filter (A) from underneath.

3

Fit the chain guide plate (one bolt), tightening torque 2-3 Nm.  
NOTE! Check that the chain tensioner is in position. Fit the bolts on the anti-vibration elements.  
Note.  
Models 340 and 345 have another type of chain tensioner, which is adjusted from the side.

4

See "Oil pump – Refitting, models 346XP, 350, 351, 353" pos. 6-9.

## Adjustable oil pump – adjustment 346XP, 350, 351, 353

Use a screwdriver or adjustable spanner to turn the adjuster screw on the pump. Turning the screw clockwise decreases the oil flow and turning it anti-clockwise increases the oil flow.

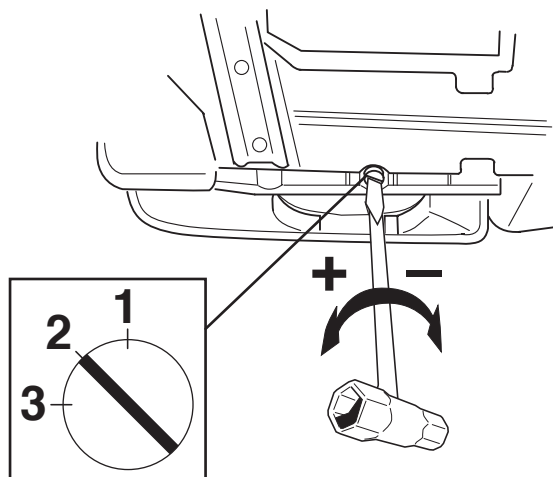

### Recommended setting:

13–15" bar	Min. setting
15–18" bar	Midway setting
18–20" bar	Max. setting

## Carburettor – removal

1

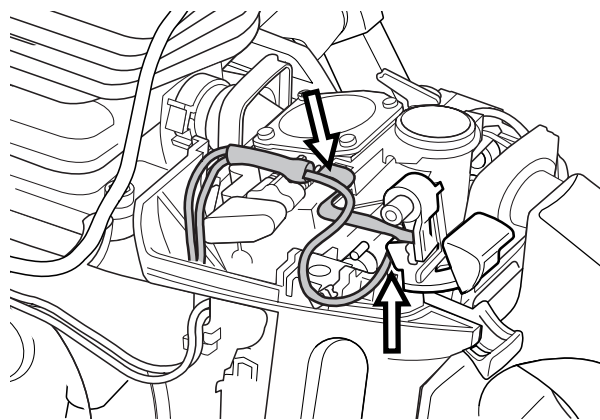

### NOTE!

**Do not use knurled pliers to disconnect or reconnect the fuel hose. This could damage the hose and lead to leakage or fracture.**

Remove the cylinder and air filter. Disconnect the leads from the stop switch and the fuel hose from the carburettor.

2

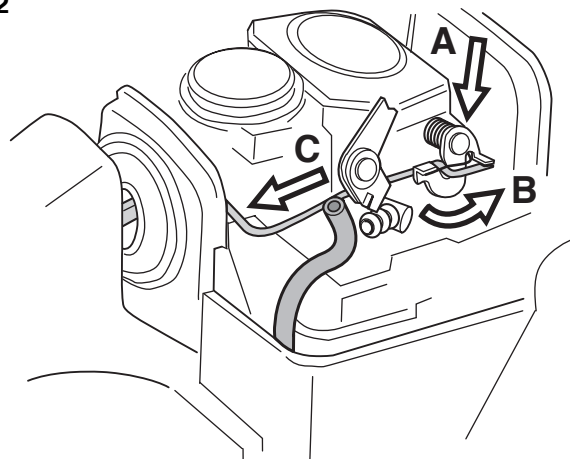

Disconnect the pushrod from the carburettor by first carefully prising up the spring over the end of the rod, where it connects to the throttle lever (A). Then press the throttle lever forwards (B) while pressing the throttle pushrod backwards (C) and lifting it off the lever. Withdraw the throttle pushrod from the tank and lift it upwards without pulling it through the rubber inlet manifold. Carefully release the carburettor assembly from the right-hand rubber mounting and lift it upwards.

3

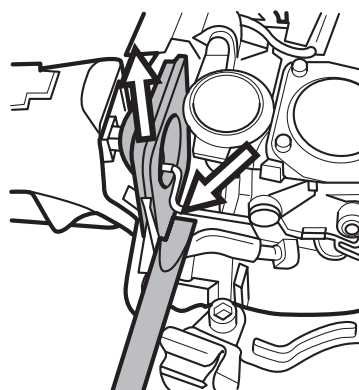

Open the spring lock on the rubber bellows.

4

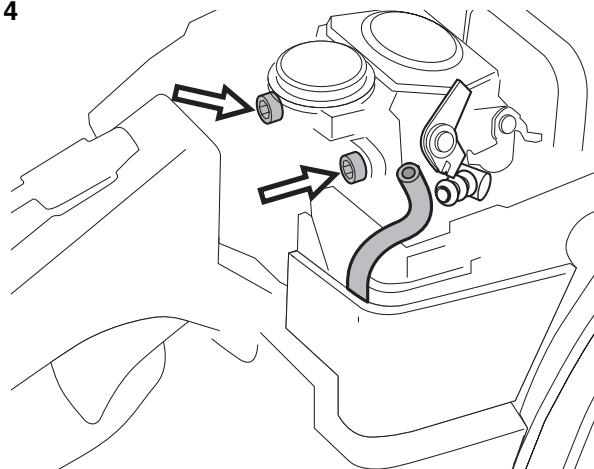

Undo and remove the carburettor bolts. Lift off the carburettor.

**On saws with a carburettor heater 346XPG, 351G, 353G**

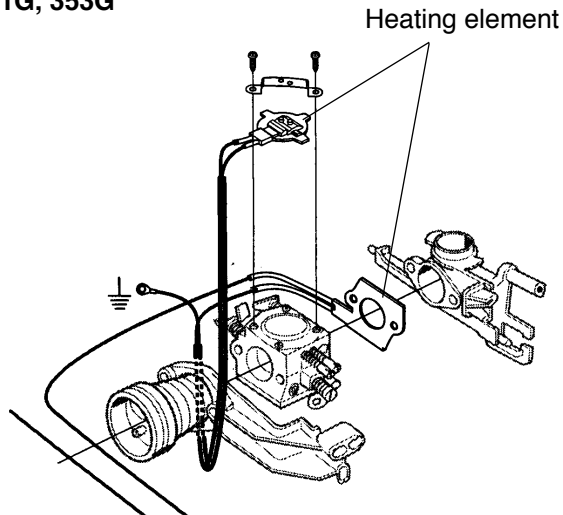

Remove the bracket's two bolts above the carburettor. Disconnect the cable connections to the carburettor heater and remove the heating element.

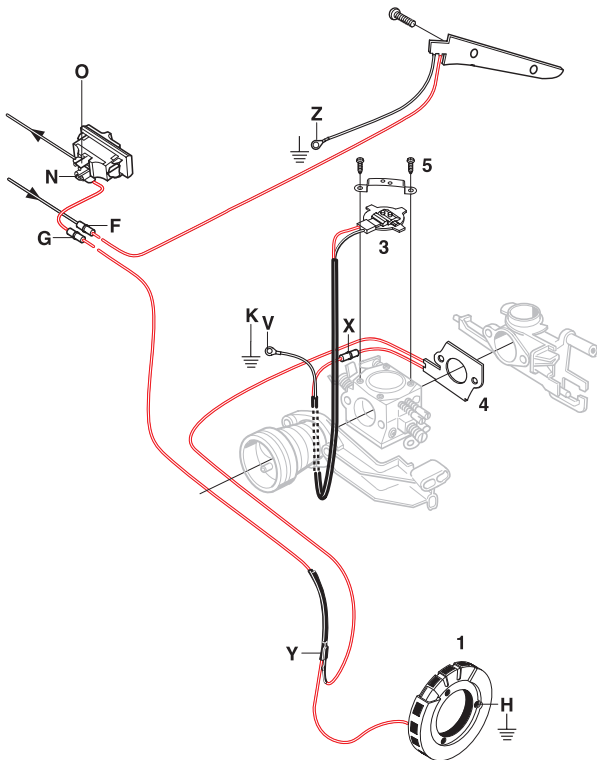

**When replacing the thermostat: Disconnect the cable from X and V. Trouble shooting, see page 20.**

**On saws with carburettor 346XPG, 351G, 353G**  
 Replacing the heating element: Lower the rear section of the tank by removing the bolt between the hand grip cover and vibration damping springs. Remove the starter and then loosen the stop screws on both sides (one is located under the starter and this must be removed first). Now disconnect the cable from X and Y.

Dismantling the carburettor: Loosen the high, low and idling jet screws.

**Carburettor – dismantling**

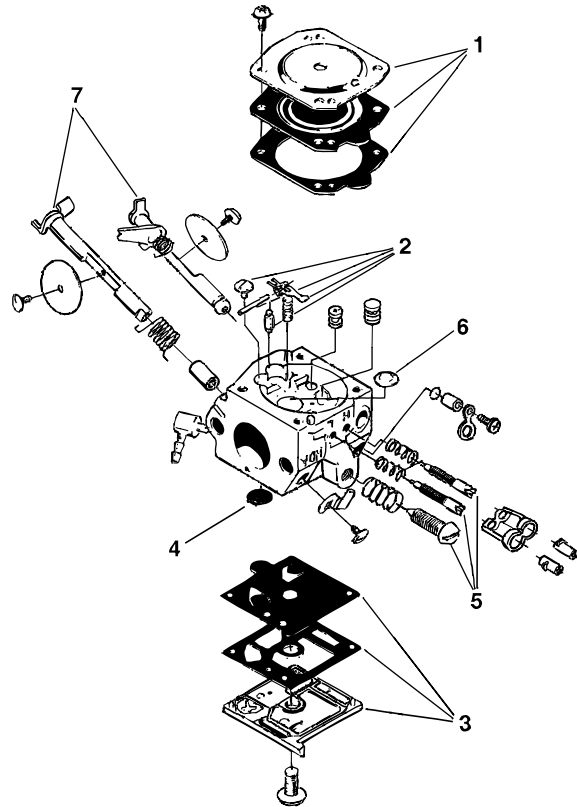

The item numbers in the diagram refer to the steps below (1–7).

- 1** Remove the cover from the metering unit and carefully remove the metering diaphragm and gasket.
- 2** Undo the screw and take out the needle valve, together with the lever arm, spindle and spring.
- 3** Remove the cover from the pump unit and carefully remove the gasket and pump diaphragm.
- 4** Remove the fuel filter.
- 5** Remove the high, low and idling jet screws. (HDA 159A high and low jet screws are protected by plastic caps which can be prised off with a screwdriver. Only on EPA, see appendix A.)
- 6** Remove the plug by first drilling a hole in it and then prising it out with a screwdriver or the like.
- 7** If necessary remove the throttle and choke valves, and remove the spindles together with the lever arms and springs.



## Cleaning and inspection

Clean all the carburettor components in petrol. Use an airline to dry off the petrol from all components. Blow through all the channels in the carburettor body and check that they are not blocked.

Check that:

- The gasket, pump diaphragm and metering diaphragm are undamaged.
- There is no play in the throttle and choke valves.

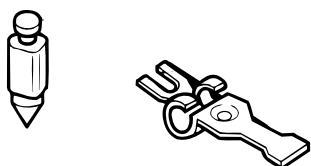

- The needle valve and its lever arm are not worn.
- The fuel filter is undamaged.
- The tips of the high and low speed jet screws are not damaged.
- The air intake duct is not cracked.

## Carburettor – reassembly

### NOTE!

Cleanliness is very important when reassembling the carburettor. Tiny particles of dirt can cause operating problems.

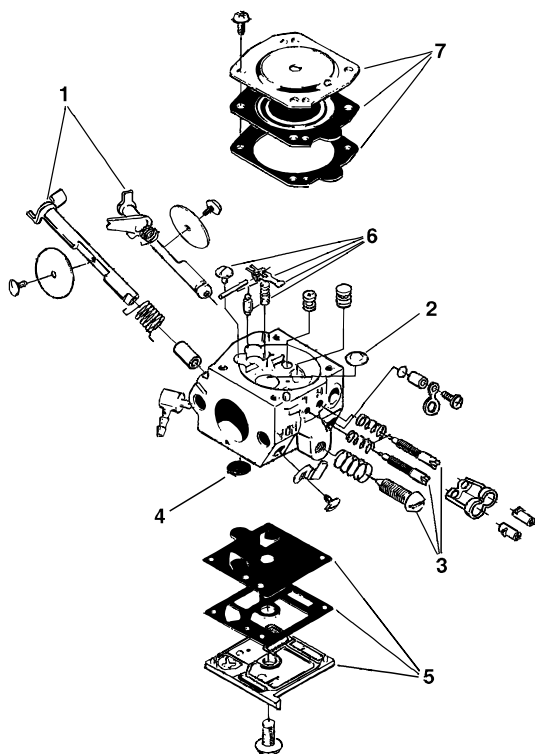

The item numbers in the diagram refer to the steps below (1–8).

**1**  
If the throttle and choke butterflies and their spindles were removed, these must be refitted. Lubricate the spindle bearings with light oil.

**2**  
Insert the plug in the hole with the convex side upwards and expand it by pressing downwards with a drift.

**3**  
Refit the high and low speed jet screws and springs, plus the idling screw. Fit the plastic caps over the high and low speed screws.

**4**  
Fit the fuel filter, using the handle of a small screwdriver.

**5**  
Fit the pump diaphragm, gasket and cover to the pump unit.

**6**

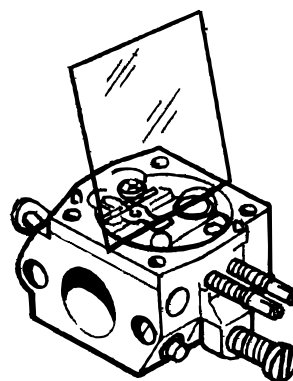

Fit the needle valve with lever arm, spindle and spring and tighten the screw. Use a rule to check that the lever arm is level with the cover face. If necessary, the lever arm can be bent slightly.

**7**  
Fit the metering diaphragm with its gasket and refit the cover to the metering unit.

**8**  
Carry out pressure testing.

## Carburettor – pressure testing

Pressure testing should be carried out with the carburettor fully assembled. Testing should always be carried out after the carburettor has been repaired, but can also be performed for troubleshooting before dismantling.

Carry out the test as follows:

- Screw in the high and low speed jet screws and back them off one turn.
- Connect pressure tester 502 50 38-01 to the carburettor fuel inlet.

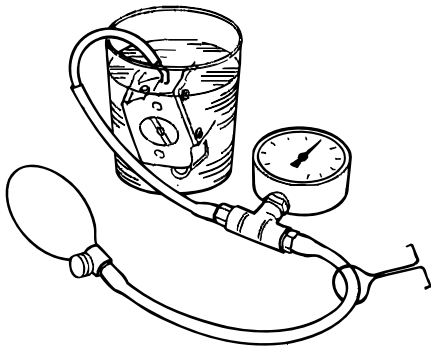

- Lower the carburettor into a beaker of water.
- Pump up the pressure to 50 kPa (0.5 bar) and clamp the pump tube.
- There should be no leakage. If leakage occurs, refer to the table below.

Leakage	Fault lies in
Diffuser jets In impulse tube Ventilation hole above metering unit	Needle valve Pump diaphragm  Control diaphragm

## Carburettor – refitting

### NOTE!

**Cleanliness is very important when reassembling the carburettor. Tiny particles of dirt can cause operating problems.**

1

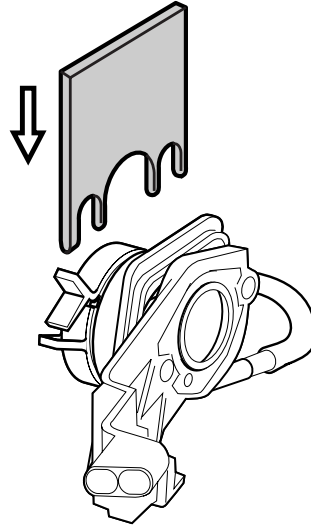

Fit stop plate 502 54 17-01 between the carburettor flange and the insulating plate.

### On saws with a carburettor heater 346XPG, 351G, 353G

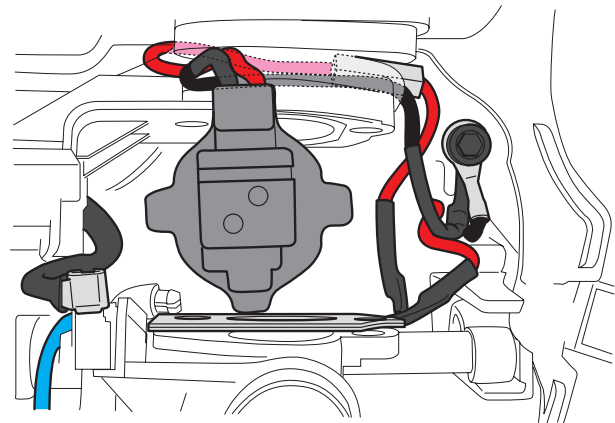

Insert the heating element between the air filter connection and carburettor as well as above the carburettor. Route the cable as illustrated above.

Tighten the bracket above the carburettor with the two bolts.

Connect the cables to the carburettor heater.

2

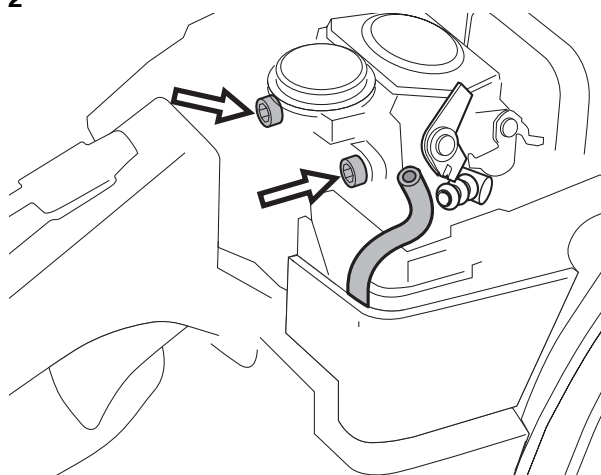

Fit the carburettor. Screw in the carburettor bolts directly from behind, without lifting the carburettor assembly. Tighten to a torque of 1–1.5 Nm. It is important to hold the carburettor flange while tightening the bolts to prevent the inlet manifold from moving.

3

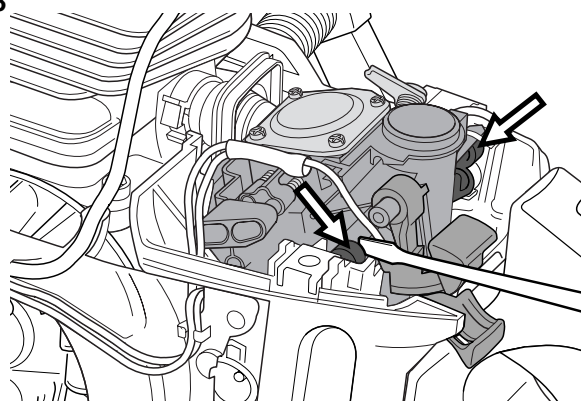

Push the rear carburettor mounting into its rubber bushing using a small screwdriver. Remove stop plate 502 54 17-01.

4

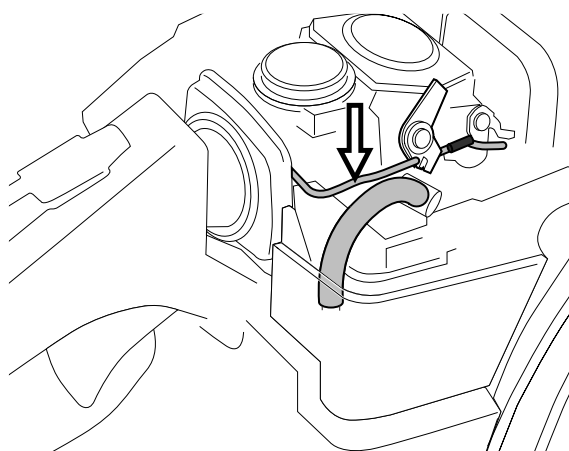

Connect the fuel hose to the carburettor. Refit the throttle pushrod at the same time as the rubber inlet manifold, press in the throttle pushrod so that it engages in the carburettor and fit the spring.

5

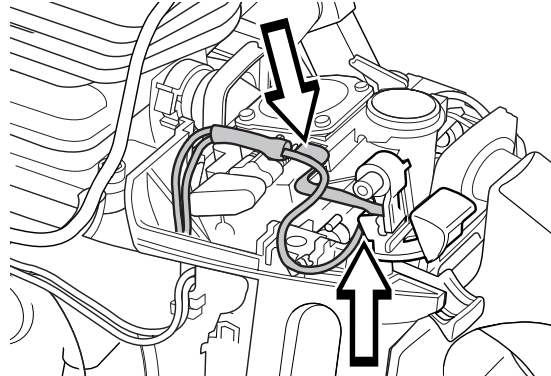

Connect the leads to the stop switch.

### Carburettor heater 346XP, 351, 353 – Refitting

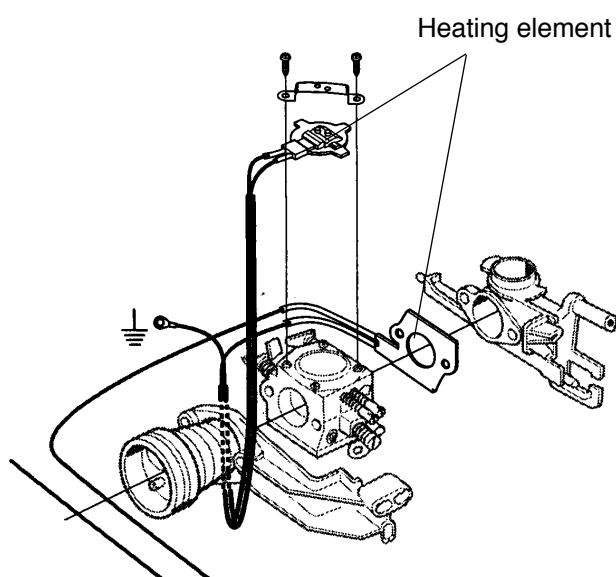

1

Fit the heating element between the air filter connection and the carburettor as well as above the carburettor.

2

Tighten the bracket above the carburettor using the two bolts.

3

Connect the leads to the carburettor heater.

Refit:

- carburettor

## Air intake system – removal

The air intake system comprises:

- inlet manifold
- insulating plate with clip
- carburettor flange
- impulse hose
- support ring

1

Remove:

- cylinder cover
- air filter
- carburettor
- HT lead
- starter assembly (340, 345)
- Fuel tank (340, 345)

2

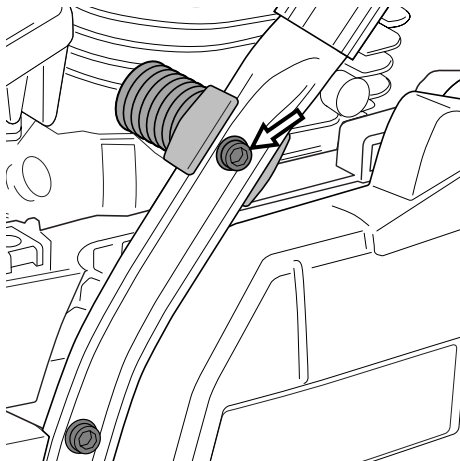

Unbolt the vibration damping spring between the cylinder and hand grip.

3

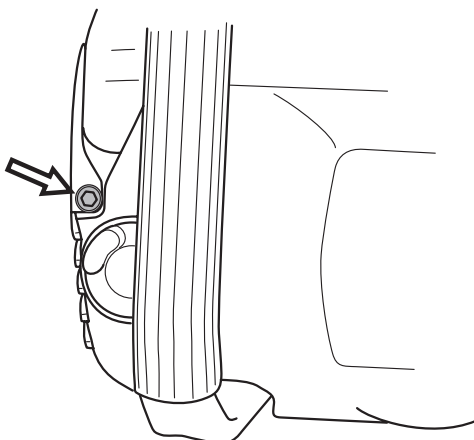

Unscrew and remove the bolt from the silencer support.

4

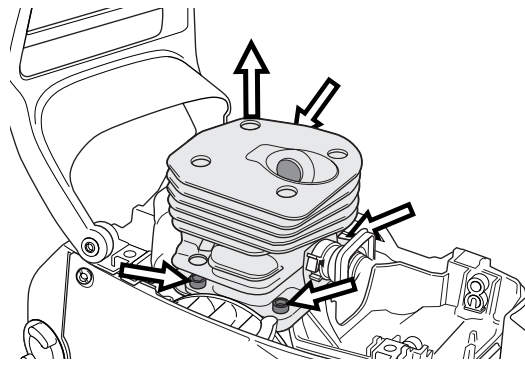

Unscrew the four cylinder bolts. Lift up the cylinder so that the intake system insulating plate is free of the crankcase.

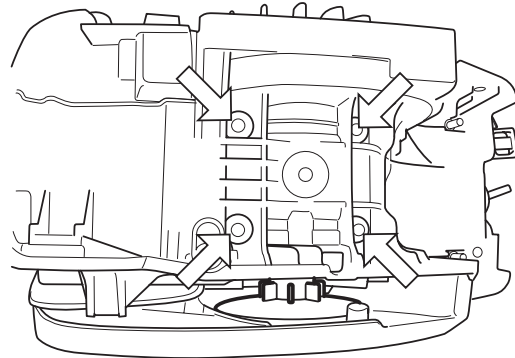

On models 340 and 345 there are cylinder bolts on the underside.

5

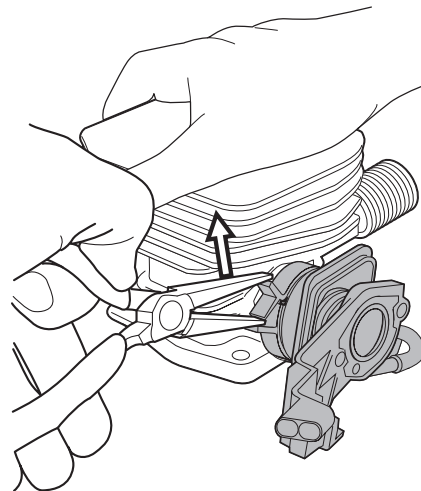

Free the insulating plate from the cylinder by releasing the clamp using pliers. Remove the complete air intake system.

6

Remove:

- support ring
- carburettor flange from the inlet manifold
- insulating plate

## Cleaning and inspection

Clean and inspect all parts carefully. If there are any cracks or other defects replace the damaged parts with new ones. Always use original parts. **NOTE!** When replacing the impulse hose it must not be lubricated with oil or grease.

## Air intake system – refitting

1

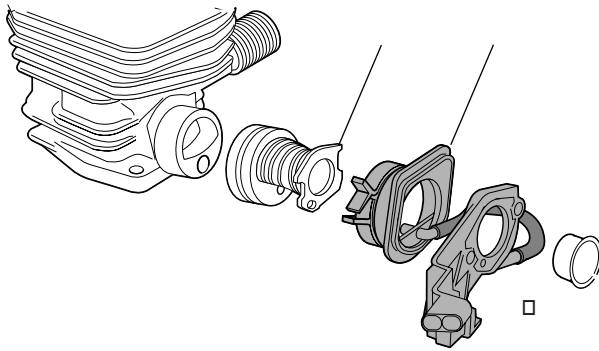

Fit the inlet manifold (A) through the insulating plate in the carburettor flange cut-out (B), and check that the insulating plate's impulse tube sits correctly in the inlet manifold. Fit the perforated brass support ring in the inlet manifold.

2

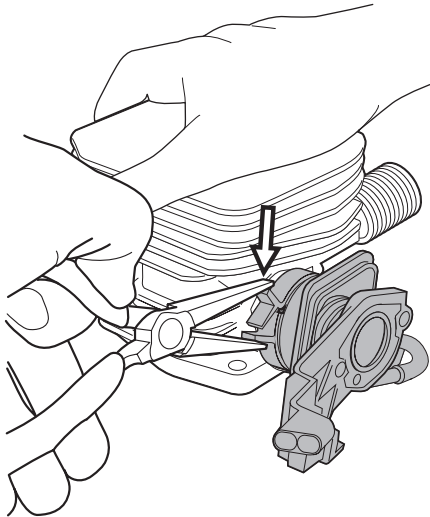

Fit the air intake system on the cylinder and snap the insulating plate into position. Check carefully that the impulse tube is correctly seated against the cylinder's impulse channel.

3

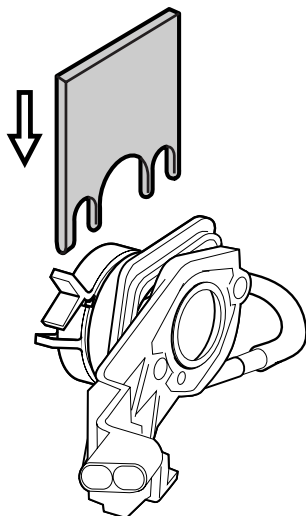

Position tool 502 54 17-01 between the carburettor flange and the insulating plate.

4

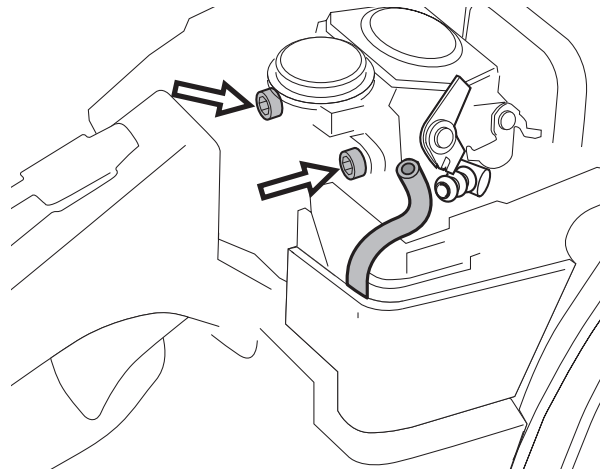

Refit the carburettor. Screw in the carburettor bolts directly from behind without lifting the carburettor assembly, tightening to a torque of 1–1.5 Nm. It is important to hold the carburettor flange securely when tightening the bolts to prevent the inlet manifold from moving.

4

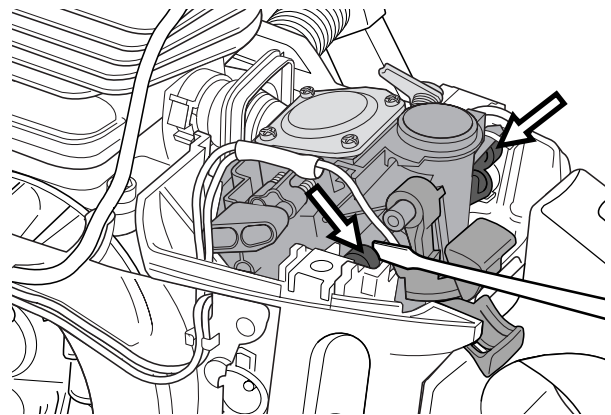

Push down the rear carburettor mounting into the rubber bushings using a small screwdriver. Remove tool 502 54 17-01.

5

Refit:

- cylinder, see special instructions
- silencer support (does not apply to 340, 345, 350)
- air filter
- HT lead
- cylinder cover
- after the test run retighten the silencer bolts to a torque of 8–10 Nm

## Carburettor – adjustment

For instructions on adjusting the EPA carburettor see appendix A.

Adjusting the carburettor involves adjusting the engine to the local conditions e.g. climate, altitude, fuel and type of two-stroke oil.

The carburettor is equipped with three adjustment options.

- L = Low speed jet
- H = High speed jet
- T = Idling adjustment screw

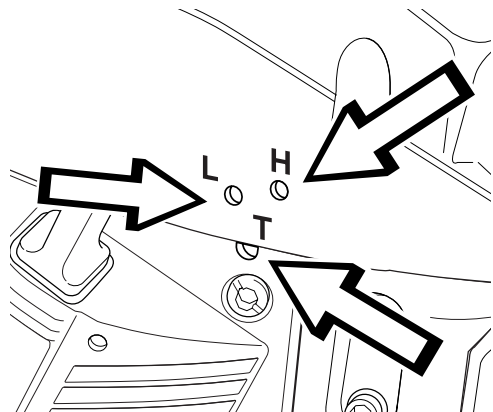

The L and H jets adjust the fuel flow to match the airflow that the throttle valve opening allows. Turning them clockwise makes the fuel/air mixture weaker (less fuel in relation to the amount of air) and turning them anti-clockwise makes the fuel/air mixture richer. A weak mixture increases the engine speed and a rich mixture decreases the engine speed.

The T screw controls the throttle position when idling. Turning the T screw clockwise gives faster idling; turning it anti-clockwise lowers idling speed.



**WARNING!**  
The guide bar, chain and clutch cover must be fitted before the saw is started, otherwise the clutch may fly off and cause injury.

### Basic settings and running in

During testing at the factory the carburettor is adjusted to the basic factory settings.

**The factory settings are H = 1 turn and L = 1 turn.**

**To ensure that engine components receive adequate lubrication (running in) the carburettor should be set to a somewhat richer fuel mixture for the chainsaw's first 3-4 running hours. This is done by adjusting the maximum speed to 6-700 rpm less than the recommended maximum speed.**

If it is not possible to check the maximum speed with a tachometer then the H jet should not be set to a weaker mixture than the basic factory setting.

**The recommended maximum speed must not be exceeded.**

### NOTE!

**If the chain turns at idling speed, the T screw should be turned anti-clockwise until the chain stops.**

### Fine adjustment

Once the chainsaw is "run in" the carburettor should be readjusted. First adjust the L jet screw, then the idling screw T and finally the H jet screw.

The recommended engine speeds are as follows:

Model	Max revs	Idle revs
340	12,500 rpm	2,700 rpm
345	12,500 rpm	2,700 rpm
346XP/G	14,200 rpm	2,700 rpm
350	13,000 rpm	2,700 rpm
350 EPA	13,000 rpm	2,700 rpm
351	13,000 rpm	2,700 rpm
353	13,000 rpm	2,700 rpm

### Basic requirements

- Before making any adjustments the air filter should be clean and the cylinder cover should be in place. If the carburettor is adjusted with a dirty air filter, the mixture will be too weak next time the air filter is cleaned. This can cause serious engine damage.
- Carefully screw in the L and H jets fully, then back them off 1 turn. The carburettor now has the settings H = 1 and L = 1.
- Start the chainsaw and allow it to warm up for 10 minutes.
- Place the saw on a flat surface so that the guide bar is pointing away from you and the guide bar and chain are not touching the surface.

### Low speed jet L

- Find the highest idling speed by slowly screwing the L screw in and then out again.
- When the highest speed has been found, screw out the L screw 1/8 - 1/4 turn.



### Fine adjustment of idling speed T

- The idling speed is adjusted using the screw marked T.
- If adjustment is necessary, screw in the idling screw T until the chain starts to turn. Then screw it out until the chain stops moving.
- The idling speed is correctly set when the engine runs smoothly in all positions and there is a clear margin to the speed at which the chain starts to move.

### High speed jet H

- The high speed jet H influences the saw power output and engine speed. If the H jet is set too weak the saw will over-rev, which could cause engine damage.
- Run the saw at full throttle for about 10 seconds. H=1.
- Then screw out the H screw 1/4 turn. H=1 1/4.
- Run the saw again at full throttle for about 10 seconds and listen to the difference in the engine note. Repeat this procedure again with the H screw screwed out another 1/4 turn. H=1 1/2.
- You have now run the saw at settings  $H \pm 0$ ,  $H = +1/4$  and  $H = +1/2$  from the factory setting. At full throttle the engine will sound different at each setting.
- The H screw is correctly adjusted when the saw "bubbles" a little at full throttle without any load.
- If there is a lot of smoke from the silencer and the saw does not run smoothly then the setting is too rich.
- Screw in the H screw to the setting that sounds right.

#### NOTE!

**For optimum adjustment, a tachometer should be used. The recommended maximum speed should not be exceeded.**

### Carburettor – correct adjustment

- When the carburettor is correctly adjusted the saw should accelerate without hesitation and the engine will burble a little at full throttle without any load.
- The chain must not turn when idling.
- If the L screw is set too weak this can make the saw difficult to start and cause poor acceleration.
- If the H screw is set too weak the saw will produce less power, poor acceleration and there is a risk of engine damage.
- If either the L or H screws are set too rich it will cause acceleration problems or too low working speed.

### Fuel tank – removal



#### WARNING!

**The fuel used in chainsaws is harmful if inhaled, may cause skin irritation and is highly flammable.**

**1**  
Empty the fuel tank.

**2**  
Remove the following:

- cylinder cover
- air filter
- clutch cover
- chain and guide bar
- starter assembly
- cable guide

**3**  
Disconnect the fuel hose from the carburettor.

**4**

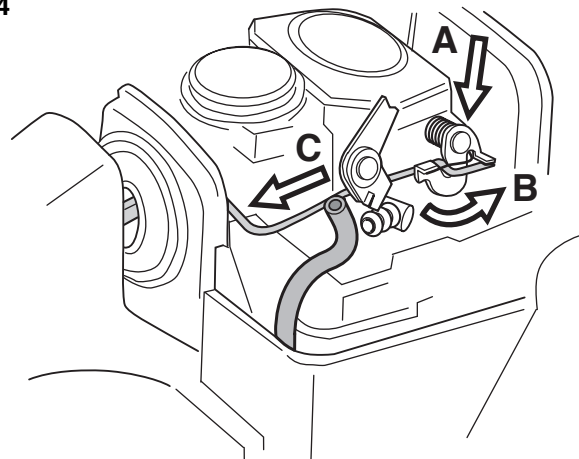

Disconnect the pushrod from the carburettor by first carefully prising up the spring over the end of the rod, where it connects to the throttle lever (A). Then press the throttle lever forwards (B) while pressing the throttle pushrod backwards (C) and lifting it off the lever. Withdraw the throttle pushrod from the tank and lift it upwards without pulling it through the rubber inlet manifold.

5

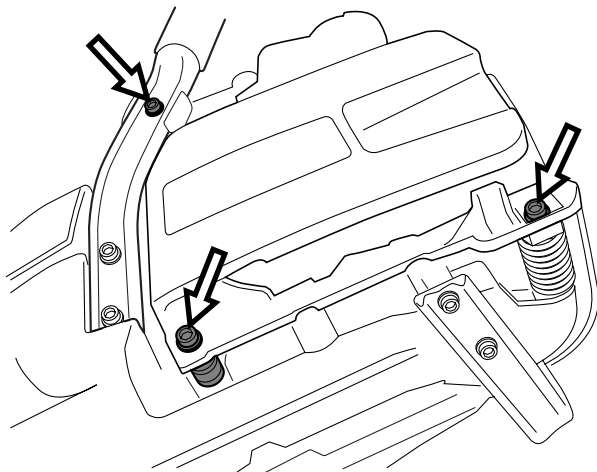
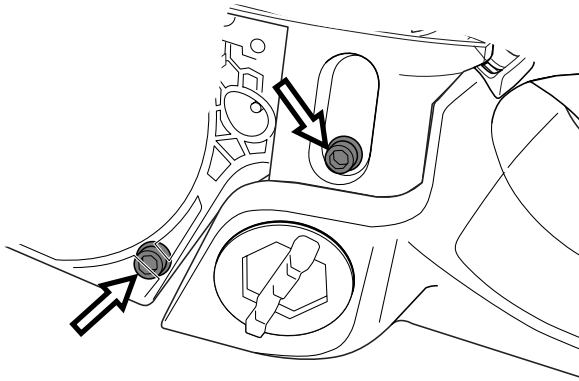

Unscrew both stops and the three vibration damping springs from the flywheel side and clutch side of the engine.

6

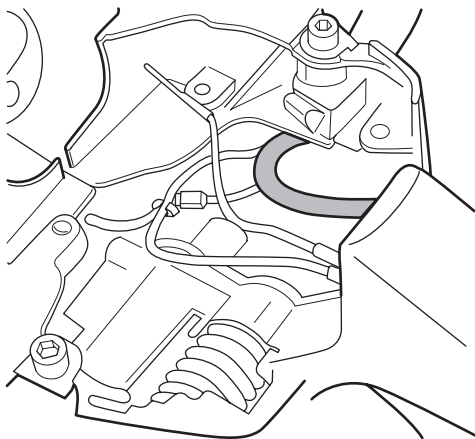

Disconnect and remove the fuel hose from the crankcase.

## Cleaning and inspection

Carefully check that:

- there are no leaks from the fuel tank
- there are no leaks from the tank filler cap
- the fuel hose is undamaged and free from wear
- the fuel filter is not clogged
- the tank vent is not blocked or leaking
- the vibration damping springs and stops are not damaged

## Replacing the fuel filter

### NOTE!

**Do not use knurled pliers to disconnect or reconnect the fuel hose. This could damage the hose and lead to leakage or fracture.**

1

First remove the old fuel filter from the tank unit using special tool 502 50 83-01.

2

Pull the fuel hose out of the tank and pull off the filter.

3

Fit the new fuel filter and feed the fuel hose back into position.

## Replacing the fuel hose

### NOTE!

**Do not use knurled pliers to disconnect or reconnect the fuel hose. This could damage the hose.**

1

Before replacing the fuel hose, measure the length of hose between the crankcase and carburettor and between the tank and crankcase. The correct hose length between the tank and crankcase is 43 mm (1.69 inches). The correct hose length between the crankcase and carburettor is 53 mm (2.09 inches).

2

Remove the fuel hose from the fuel tank using tool 502 50 83-01. Trim off 5 mm (0.20 inches) from the mitred end of the hose. Fit the fuel filter and reinsert the hose in the tank.



## Tank vent – testing

1

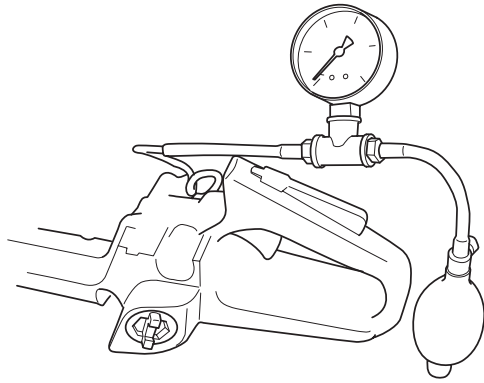

Connect pressure gauge 502 50 38-01 to the fuel hose. Pump the pressure up to 50 kPa (0.5 bar). The pressure should drop to 20 kPa (0.2 bar) within 60 seconds.

2

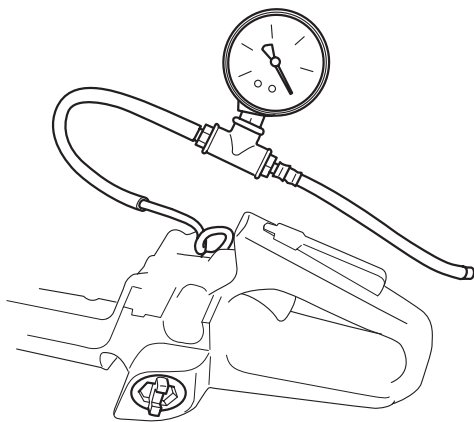

Use gauge 502 50 37-01 to measure vacuum. Readings should be as follows: the vacuum should increase from 30 to 15 within 30 seconds. If readings are outside this range the vyon plugs must be replaced.

## Fuel tank – refitting

1

Insert the fuel hose into the carburettor chamber. Refit the fuel tank.

2

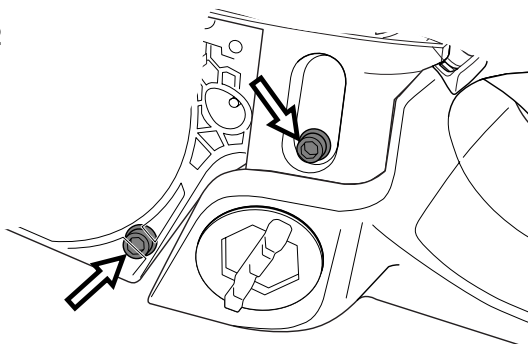

Bolt the front vibration damping spring into position, followed by both stops and the remaining two vibration damping springs. Tighten to a torque of 2–3 Nm. Check that both vibration damping springs and the stops are correctly seated on the crankcase. Incorrect fitting may result in higher vibration levels.

3

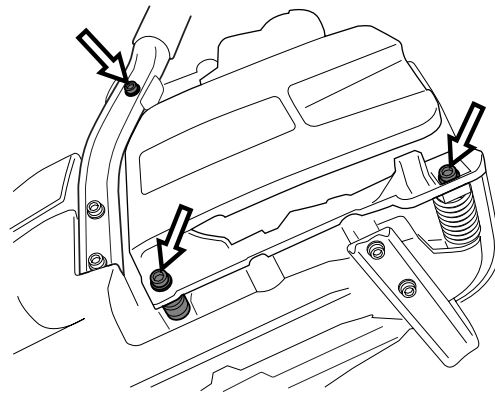

Fit the throttle pushrod in the tank and connect it to the carburettor. Refit the spring.

4

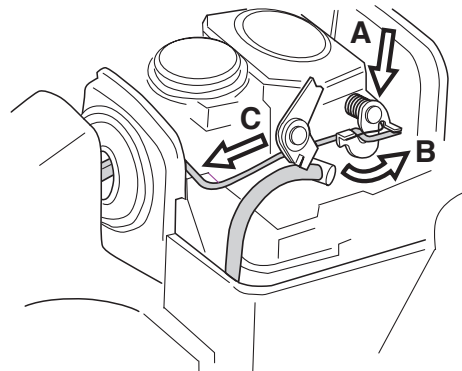

Connect the fuel hose to the carburettor. Check that the hose is not kinked or too long to be clamped between the crankcase and tank. The correct hose length between the tank and crankcase is 43 mm (1.69 inches). The correct hose length between the crankcase and carburettor is 53 mm (2.09 inches) excluding the mitred section.

5

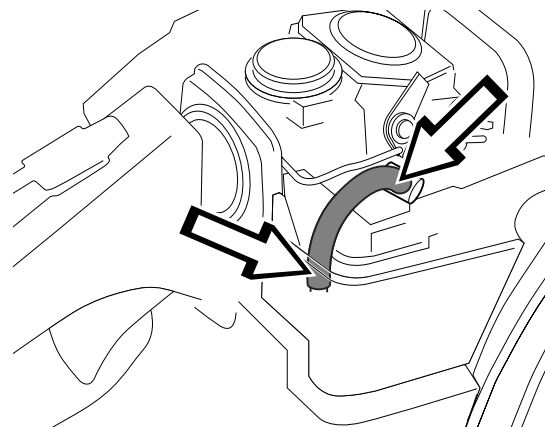

Connect the fuel hose to the carburettor.

6

Then refit:

- cable guide
- starter assembly (2.5–3 Nm)
- chain and guide bar
- clutch cover
- air filter
- cylinder cover

## Piston and cylinder – removal

1

Remove:

- cylinder cover
- carburettor (see “Carburettor – removal”)
- silencer
- spark plug
- fuel tank (applies to 340, 345)

2

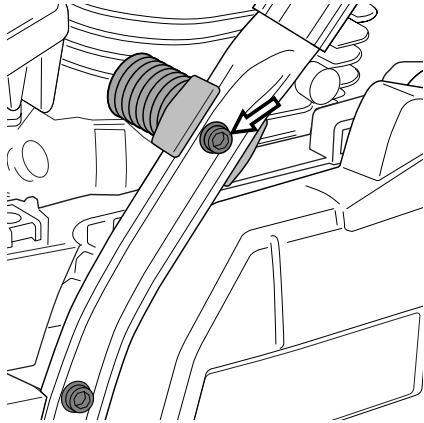

Unbolt the vibration damping spring from the hand grip.

3

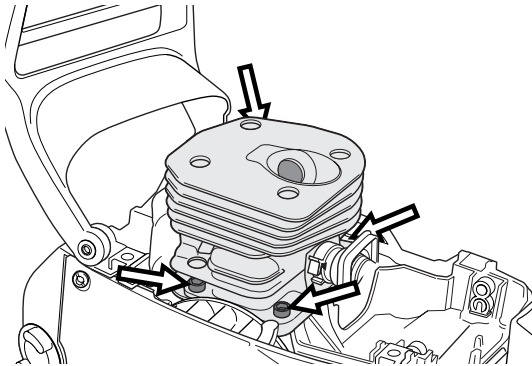

Undo the four cylinder bolts and lift the cylinder off carefully.

### Models 340, 345

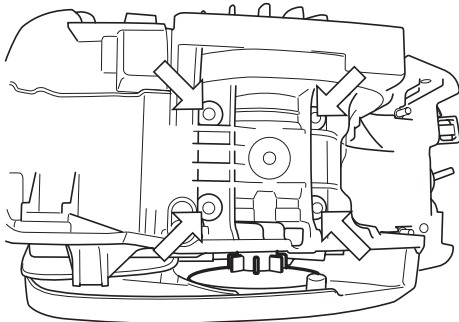

Undo the four cylinder bolts from the underside and lift the cylinder off carefully.

4

Cover the opening in the crankcase.

5

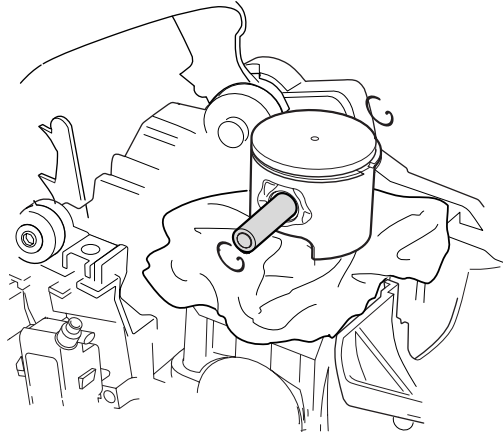

Remove the circlips from the ends of the gudgeon pin and press it out. Then lift off the piston.

6

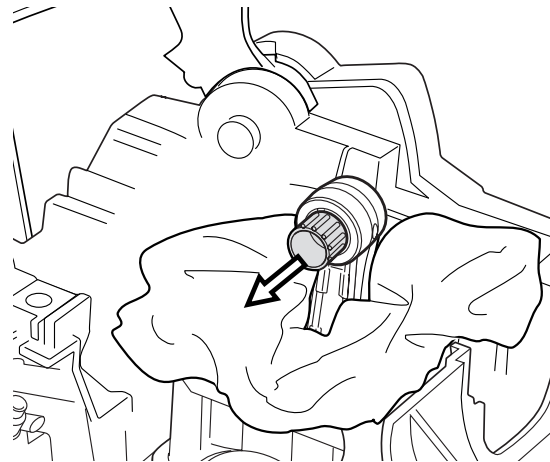

Remove the bearing from the little end of the connecting rod.

7

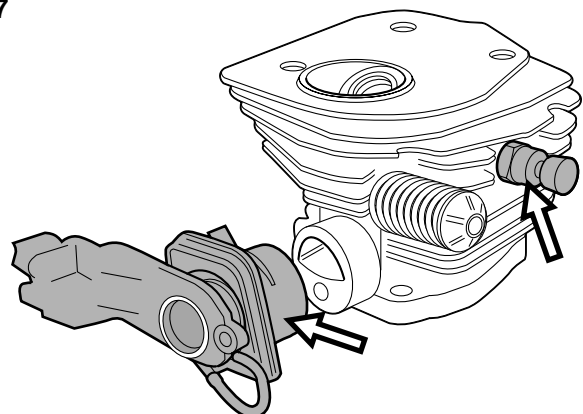

### If replacing the cylinder:

Unscrew the decompression valve. Remove the intake system, see “Air intake system – removal”.

8

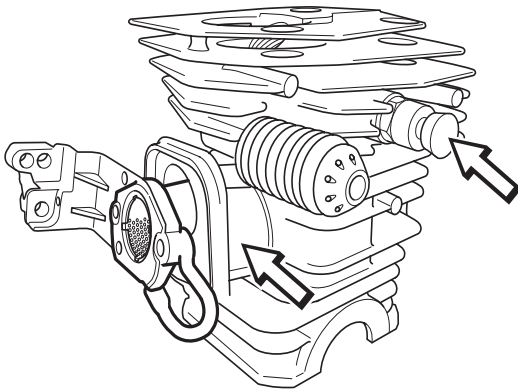
**When replacing the cylinder 340, 345:**

Unscrew the decompression valve. (345)  
Remove the intake system, see "Air intake system – removal".

Model 350 is fitted with a spacer, which is secured using four bolts from the underside. The spacer does not however need to be removed when removing the cylinder.

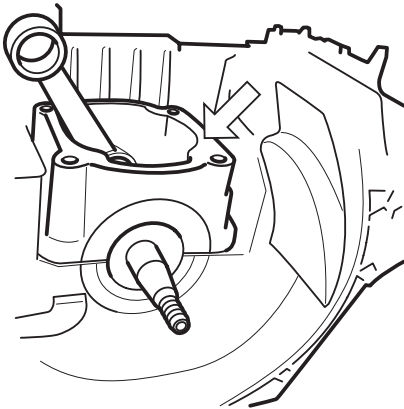
**Cleaning and inspection**

Clean all the components, scraping off all traces of old gasket and carbon from the following places:

- Piston crown
- Top of the cylinder bore
- Cylinder exhaust port
- Decompression valve channel (340, 346XP, 350, 351, 353)
- Cylinder base and/or crankcase

Check the following:

- The surface coating of the cylinder is not worn through, especially in the upper part of the cylinder.
- The cylinder is free from score marks and areas of wear.
- The piston is free from score marks. Small scratches can be polished out with fine emery paper.
- The piston ring is not burnt into its groove.

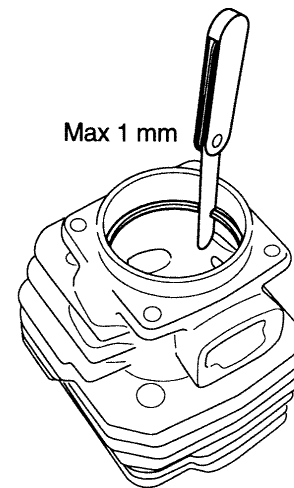

- Measure piston ring wear. This should not exceed 1 mm. Use the piston to push down the piston ring.
- The needle roller bearing is undamaged.
- The inlet manifold is undamaged.
- Pressure test the decompression valve.
- Also refer to Jonsered's Analysis guide for piston failures, art. no. 108 07 01-01.

**Decompression valve – pressure testing**

1

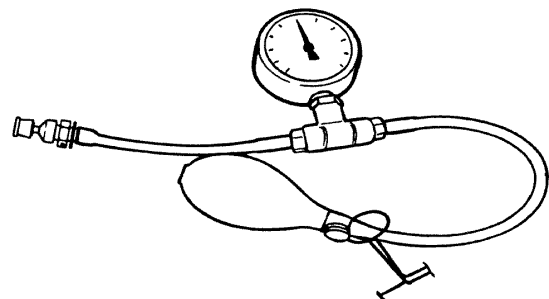

Connect tool 502 50 38-01 to the decompression valve.

2

Pump up the pressure to 80 kPa (0.8 bar).

3

Wait 30 seconds.

4

The pressure should not be less than 60 kPa (0.6 bar).

## Piston and cylinder – refitting 346XP, 350, 351, 353

1

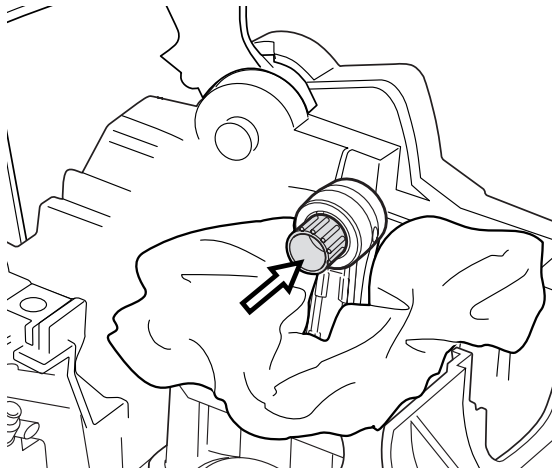

Lubricate the little end bearing with two-stroke oil and insert it in the connecting rod.

2

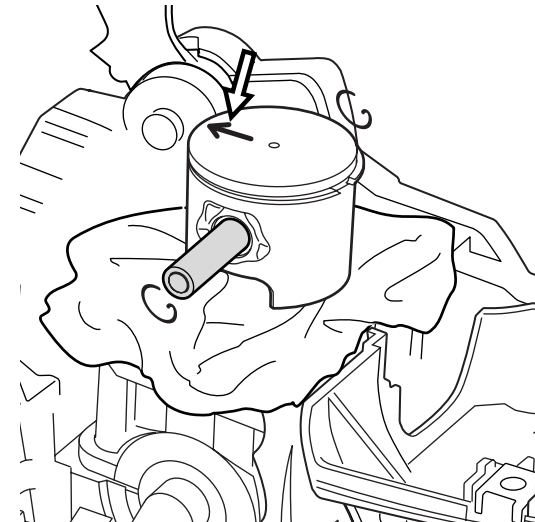

Fit the piston with the arrow pointing towards the exhaust port. Push in the gudgeon pin and fit the circlips. If replacing the cylinder, fit the decompression valve, tightening to a torque of 12–14 Nm.

3

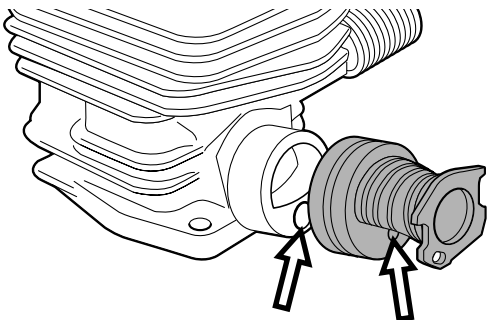

Fit the inlet manifold 503 86 63-01 to the cylinder. Check that the impulse tube is correctly seated in the impulse channel.

### NOTE!

It is very important that there are no leaks in the inlet system, otherwise the engine may seize.

4

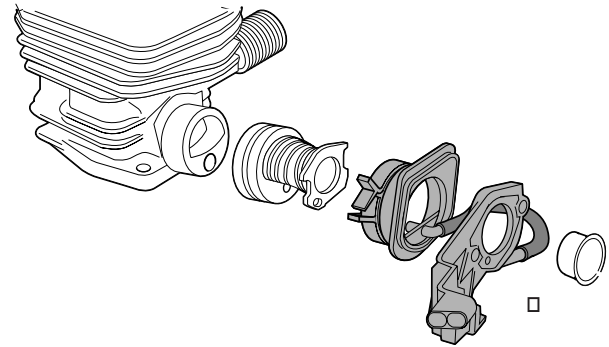

Press the insulating plate 503 86 62-01 onto the cylinder. Check that the impulse tube connected to the insulating plate is seated correctly in the inlet manifold and lock the clamp over the manifold.

5

Lubricate the piston ring and piston with two-stroke oil.

6

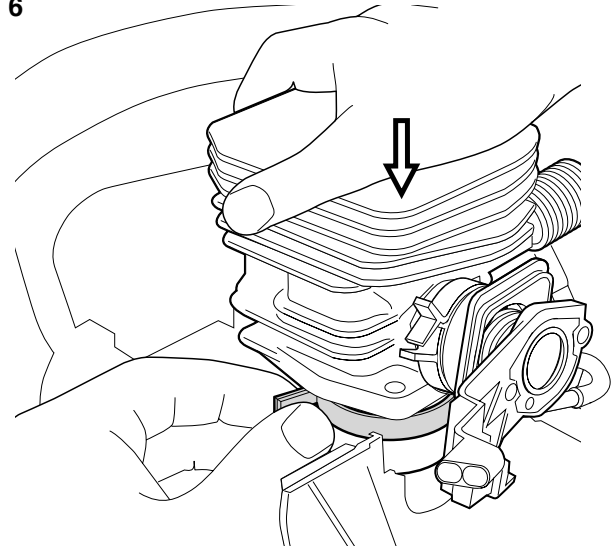

Fit a new cylinder base gasket. Compress the piston ring with tool 502 50 70-01 and lower the cylinder over it carefully.

7

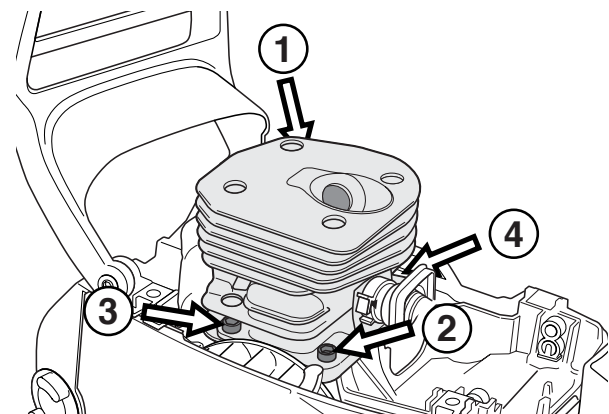

Fit the cylinder bolts, tightening them in diagonal pairs to a torque of 8–10 Nm.

## Piston and cylinder – refitting 340, 345

1-5

See Piston and cylinder 346XP, 350, 351, 353  
–Refitting points 1-5.

6

Apply silicone adhesive/sealing compound (03-7062) to the crankcase's contact surfaces with the cylinder.

Carefully slide the cylinder down over the piston towards the big end bearing.

Note!

Work is facilitated if the crankshaft complete with bearing and piston is released from the crankcase and the piston is pushed into the cylinder. The unit is then refitted in the crankcase.

7

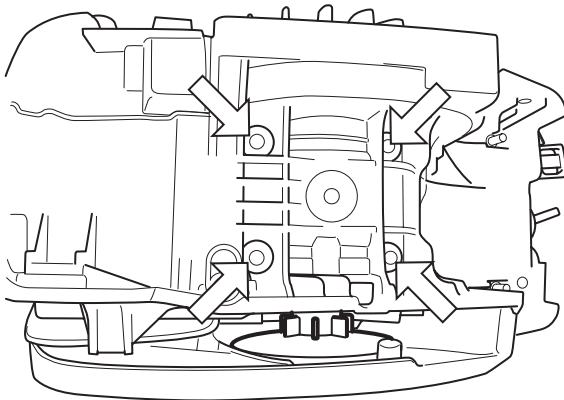

Fit the cylinder bolts, tightening crosswise to a torque of 13–15 Nm.

8

Pressure test the cylinder.

9

Refit:

- spark plug, tighten to a torque of 15 Nm
- carburettor, see "Carburettor – refitting",
- silencer, tighten to a torque of 8–10 Nm
- cylinder cover

### NOTE!

If a new piston or cylinder has been fitted the saw must be run for the first 3–4 hours with carburettor adjusted to the factory settings.

## Cylinder – pressure testing

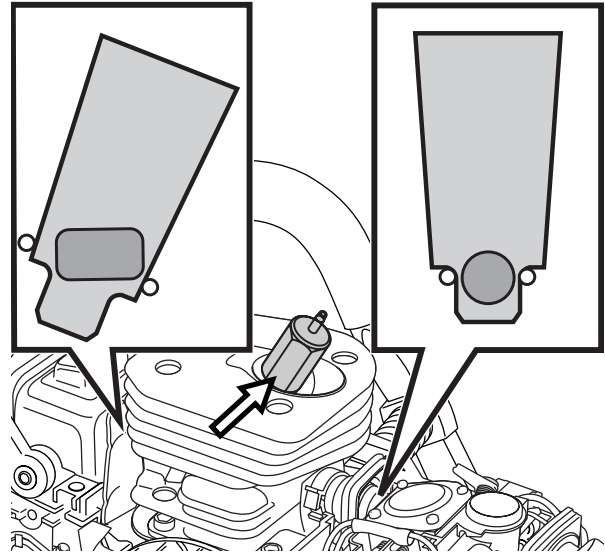

- Loosen the carburettor bolts so that the carburettor can be moved back about 4 mm. Insert cover plate 502 54 11-02 between the carburettor and the carburettor flange. Tighten the carburettor bolts to a torque of 1–1.5 Nm.
- Loosen the silencer bolts so that the silencer can be moved back about 4 mm. Insert cover plate 502 54 11-02 between the silencer and the exhaust flange on the cylinder flange. Tighten the silencer bolts to a torque of 8–10 Nm.
- Unscrew and remove the spark plug. Screw in pressure test nipple 503 84 40-02. Connect tool 502 50 38-01 to the nipple. The decompression valve must be closed. To check the decompression valve itself, see "Decompression valve – pressure testing".
- Pump up the pressure to 80 kPa (0.8 bar).
- Wait 30 seconds.
- The pressure should not be less than 60 kPa (0.6 bar).
- Remove the cover plates from the silencer and carburettor, tighten the bolts to the specified torque. Remove the pressure test nipple 503 84 40-02 and refit the spark plug.



### WARNING!

After pressure testing the cylinder, check that the inlet manifold is seated correctly, otherwise the saw may be damaged.



## Crankcase and crankshaft – dismantling 346XP, 351, 353

1

Remove the following:

- guide bar and chain
- clutch cover
- cylinder cover
- starter assembly\*
- ignition system\*
- generator\*
- centrifugal clutch\*
- oil pump\*
- bark rest
- chain tensioner
- throttle pushrod
- carburettor\*
- carburettor base
- silencer\*
- piston and cylinder\*
- fuel tank\*

\* See special instructions.

### NOTE!

Take care to prevent dirt or foreign particles getting into the bearings.

2

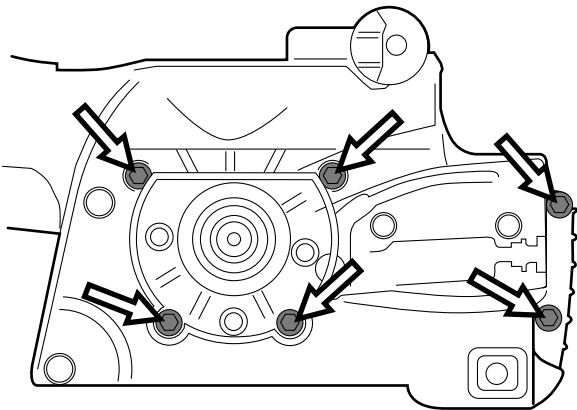

Unscrew the 6 bolts that hold the crankcase together.

3

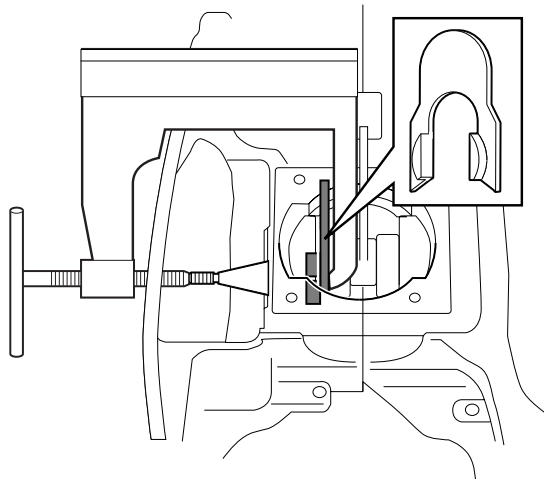

Split the crankcase with the aid of tool 502 51 61-01 (A) and stop plate 502 54 18-01 (B), working from the flywheel side of the saw.

4

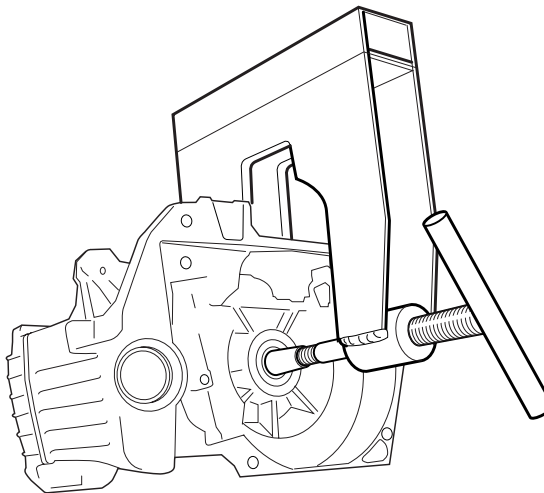

Press the crankshaft out of the flywheel side of the crankcase using tool 502 51 61-01.

5

Do the same on the clutch side **without** using stop plate 502 54 18-01.

## Crankshaft complete - dismantling 340, 345, 350

1

Remove the following:

- chain and bar
- clutch cover
- cylinder cover
- starter assembly\*
- ignition system\*
- generator
- centrifugal clutch\*
- throttle pushrod
- carburettor\*
- silencer\*
- piston and cylinder\*
- fuel tank\*

\* See special instructions.

2

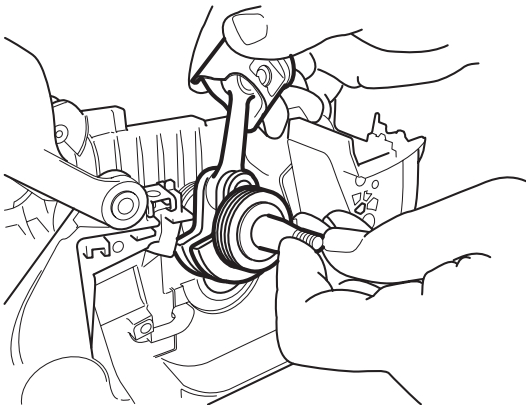

Lift the crankshaft completely out of the crankcase.

**350:**

Unbolt the four bolts from underneath and lift off the spacer.

Lift the crankshaft completely out of the crankcase.

## Crankshaft bearings – replacement 346XP, 351, 353

If the crankshaft bearings are to be replaced, tap them out gently using drift 502 70 84-01.

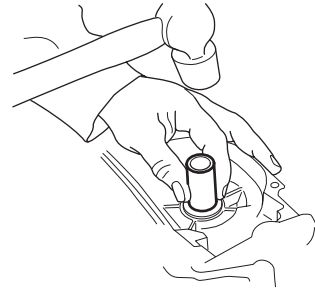

The new bearings must be shrunk-fit into the crankcase using a hot air gun.

### Cleaning and inspection

Clean and inspect all parts carefully.

### Sealing ring – replacement

Remove the sealing ring from the magnet side using tool 502 50 55-01.

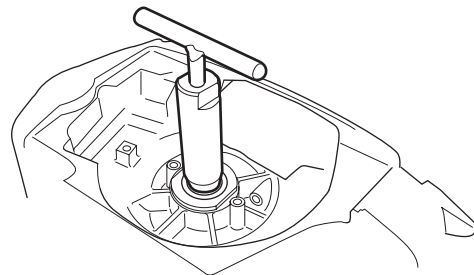

### Sealing ring replacement - drive side

Remove the oil pump.

1

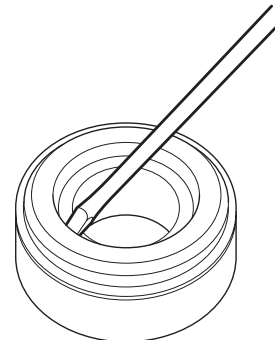

Pry up the sealing ring from the bearing by using a small screwdriver or the like.

Note. The sealing ring can be replaced without the need of removing the bearing.

2

Press the new sealing ring into the bearing.

## Cleaning and inspection

Clean and inspect all parts carefully.

## Sealing ring – replacement

Remove the sealing ring from the crankcase using a small screwdriver.

### NOTE!

Take care to avoid damaging the crankcase.

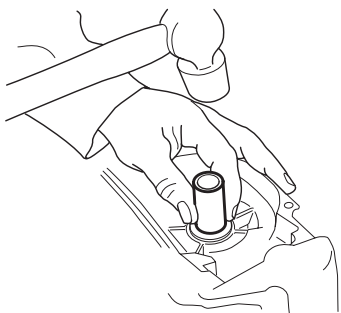

To fit the sealing ring use the sleeve that is supplied with 502 50 30-16.

The end with the half moon is used for the sealing ring on the clutch side, which must be fitted flush with the surface of the crankcase.

The other end of the sleeve is used to fit the sealing ring on the flywheel side and ensures that the sleeve is fitted at the correct depth, 1.8 mm. Lubricate the sealing rings with oil.

## Crankshaft bearings 340, 345, 350 – replacement

Remove:

- The crankshaft complete from the crankcase, see page 47.

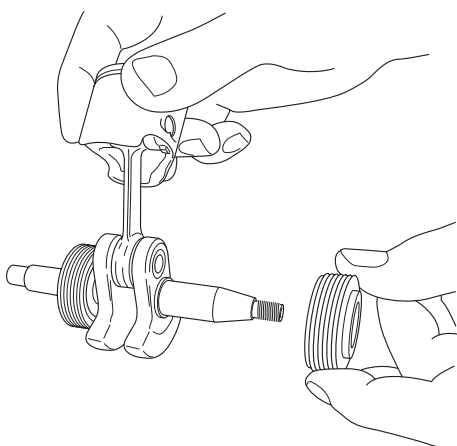

**1**  
Pull off the crankshaft bearing from crankshaft.

**2**  
Fit a new bearing on the crankshaft.

## Crankcase and crankshaft – reassembly 346XP, 351, 353

**1**

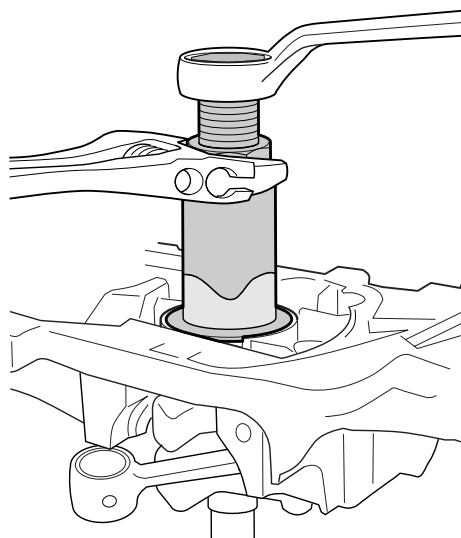

Hold the clutch side of the crankcase in a vice. Pull the crankshaft into its bearing using assembly tools 502 70 84-01 and 502 70 45-07.

**2**

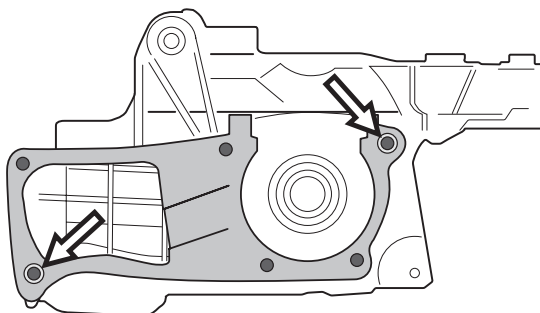

Check that the guide pins are in place. Fit a new gasket to the mating surface of the clutch side of the crankcase.

**3**

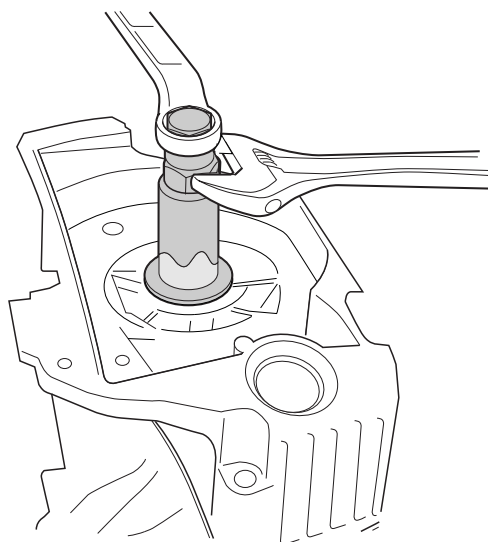

Place the flywheel side of the crankcase over the crankshaft and pull the two crankcase halves together using assembly tools 502 70 84-01 and 502 70 45-06.



4

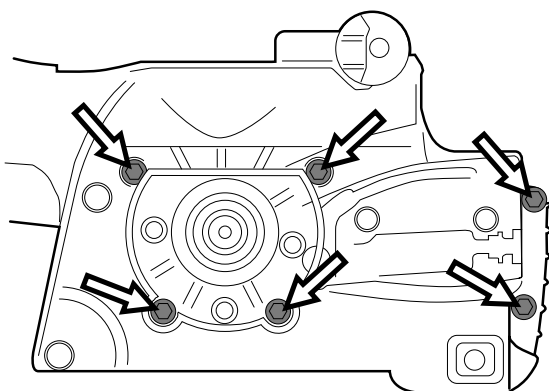

Fit and tighten the six crankcase bolts to a torque of 8–10 Nm. Check that the crankshaft rotates freely.

5

Refit the following parts:

- bark rest
- oil pump\*
- chain tensioner
- centrifugal clutch\*
- fuel tank\*
- piston and cylinder\*
- generator\*
- carburettor base
- carburettor\*
- throttle pushrod
- silencer\*
- ignition system\*
- starter assembly\*
- cylinder cover
- clutch cover
- guide bar and chain

\* See special instructions.

#### NOTE!

If a new crankshaft has been fitted the saw must be run in for 3-4 hours with the carburettor adjusted to the factory settings.

## Crankshaft complete 340, 345, 350 – reassembly

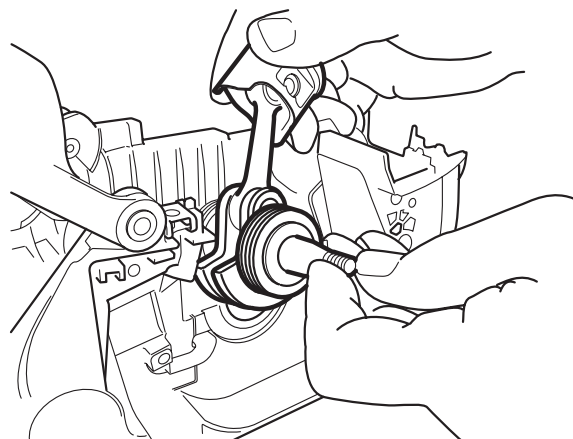

1

Fit the crankshaft complete in the crankcase.

### 350:

Fit and tighten the four bolts holding the spacer from underneath and fit the crankshaft complete in the crankcase.

Refit the following parts:

- piston and cylinder\*
- fuel tank\*
- silencer\*
- carburettor\*
- throttle pushrod
- centrifugal clutch\*
- generator\*
- ignition system\*
- starter assembly\*
- cylinder cover
- clutch cover
- chain and bar

\* See special instructions.

## Repairing damaged threads

A repair kit, 503 27 33-01, is available for repairing damaged threads.

First drill out the hole using:

**6.1 mm** drill bit for magnesium crankcase

Then screw in the thread insert using a suitable bolt and spanner.

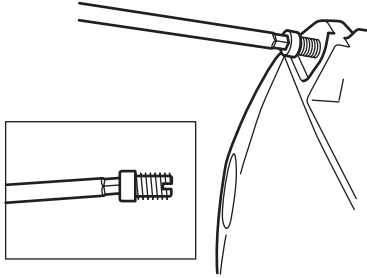

## Thread insert

A damaged thread can be repaired using a thread insert. The slotted part of the thread insert is screwed in first, as this is the cutting part.

To repair a thread that was originally designed for a PL5 screw: first drill out with a 6.1 mm diameter drill bit, then screw in the thread insert using a suitable screw and spanner.

To repair a thread that was originally designed for a MT6 screw: first drill out with a 7.1 mm diameter drill bit, then screw in the thread insert using a suitable screw and spanner.

This type of thread insert is best suited for use in plastic and magnesium, but not for repairing threads in aluminium. In that case use a helicoil insert with metric screw.

New part no.	Description
503 27 39-01	PL5
503 27 40-01	MT6

**PL**

**MT**

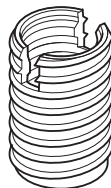
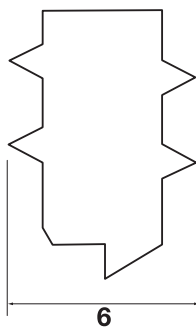
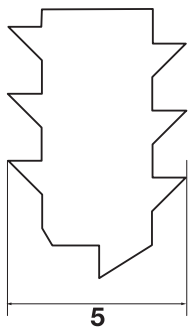

## Guide bar bolts – replacement

**1**

Drain the oil tank.

**2**

Knock through the old guide bar bolt so that it falls into the oil tank.

**3**

Remove the bolt from the oil tank.

**4**

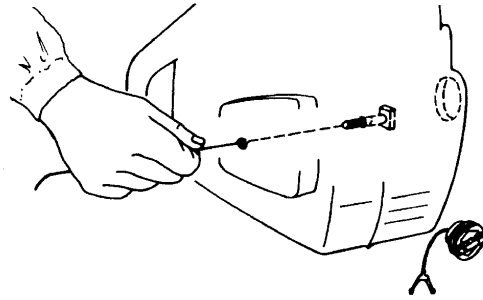

Fasten a steel wire to the thread of the new bolt, feed the steel wire into the oil tank and out through the bolt hole in the crankcase.

**5**

Pull the steel wire until the bolt comes out through its hole.

**6**

Pull through the bolt with its nut. Place a spacer between the nut and crankcase.

**7**

Check that the square shoulder of the bolt is correctly seated in the recess in the crankcase.

**8**

Refill with chain oil.

# Appendix A

## Basic adjustment for EPA II carburetors

After replacing the carburetor or high speed and/or low speed needle on an EPA (The US Environmental Protection Agency) certified product a basic adjustment must be carried out as described below in order to meet the EPA-requirements. This to achieve as low emissions as possible. This instruction is made for USA & Canada only. On EPA carburetors both the H- and L-needles are fitted with caps to prevent the chain saw operator from changing the adjustment above EPA standard. The caps can be removed to achieve richer or leaner adjustments. To set the needles correctly an adjustment sleeve is fitted from the factory over the caps to lock them in maximum allowed settings.

When correctly set the caps must be fixed on the needles. The adjustment sleeve then can be removed. Over the caps on complete sparepart carburetor, there is a plastic sleeve which is intended to lock the caps at the richest position (anticlockwise towards stop) during the time that the needles are adjusted. When the adjustment is complete and the caps have been fixed on the needles, the sleeve is no longer of any function and can be removed.

NOTE! On the complete spare part carburetor, the L-needle is adjusted from the factory.

### NOTE! Before making any adjustments the following must be done!

- Mount, for this model, approved bar & chain combination (See Technical data in the Operator's manual).

Model	
340/345/350	16"
346XP/351	16"

- The chain should not be tensioned more than that it remains ~0,2 inches to the bar.
- Mount a **new** air filter.

### Replacement of the H-needle or complete carburetor

1. Screw the new H-needle to the bottom and turn it counterclockwise "A" turns.

Model	
340/345/350	A = 3/4
346XP/351	A = 3/4

#### 2. Check that:

The H-cap is adjusted to its richest setting. (Turned counterclockwise to stop). The cap is not fixed to the needle, it should rotate independently. Adjust the L-cap to a center position (1/4 turn counterclockwise = minimum, 1/4 turn clockwise = maximum).

3. Start the engine. If necessary, adjust the idling speed with the T-screw until the chain stops.
4. Adjust the H-needle to give a top speed of "B" rpm.

Model	
340/345/350/351	B = 12 000
346XP	B = 13 000

Use a narrow blade screwdriver (Ref.no. 531 00 48-63) and insert it through the hole in the cap (max. blade width 2 mm/0.08 inch).

5. Let the engine run at "B" rpm ~ 1 minute, until warm.

6. Adjust the H-needle to a top speed of "C" rpm.

Model	
340/345/350/351	C = 13 700
346XP	C = 14 300

7. Check that the H-cap is still adjusted to its richest setting. (Turned counterclockwise to stop). **NOTE! The H-needle must not rotate!**
8. Gently knock the H-cap into position. Use a 5 mm/0.2 inch mandrel (for ex. the locking pin for the bevel gear ref.no. 502 02 61-03). This is a basic carburetor adjustment. Further fine adjustments, within the limits the caps allow, may be necessary to achieve optimum performance. See the Operator's manual.

### Replacement of the L-needle

1. Take off the cap from the L-needle using e.g. a pair of cutting pliers and unscrew the needle.
2. Screw the new L-needle to the bottom and then turn it counterclockwise "D" turns.

Model	
340/345/350	D = 1 1/2
346XP/351	D = 1 1/2

3. Press a new L-cap on the L-needle to the first stop, which means that the cap is not fixed to the needle, it should rotate independently.
4. Adjust the L-cap to the richest position (turned counterclockwise to stop) without turning the needle.
5. Let the engine run at ~ "E" app.1 minute until warm and then let it run on idle.

Model	
340/345/350/351	E = 12 000
346XP	E = 13 000

6. Adjust the idle speed to "F" rpm.

Model	
340/345/350	F = 2 700
346XP/351	F = 2 700

7. Adjust the L-needle until the highest possible idling speed is achieved and then turn the L-needle 1/2 turn counterclockwise. Use a narrow blade screwdriver w. ref.no. 531 00 48-63 and insert through the hole in the cap (max. blade width 2 mm/0.08 inch).

### NOTE! If the chain rotates, turn the idling speed screw (T) counterclockwise until the chain stops.

8. Check that the L-cap is still adjusted to its richest position. (Turned counterclockwise to stop).

### NOTE! The L-needle must not rotate!

9. Gently knock the L-cap into position. Use a 5 mm/0.2 inch mandrel (for ex. the locking pin for the bevel gear ref.no. 502 02 61-03).

This is a basic carburetor adjustment. Further fine adjustments, within the limits the caps allow, may be necessary to achieve optimum performance. See the Operator's manual.



[www.husqvarna.com](http://www.husqvarna.com)