

357XP/359

Workshop manual

101 91 17-26

Workshop manual

Husqvarna 357XP/G and 359/G

Contents

Introduction	2
Safety regulations	3
General instructions	3
Special instructions	3
Special tools	4
Technical data	6
Construction and function	8
Carburettor	8
Troubleshooting	10
Repair instructions	12
Chain brake	12
Silencer	14
Chain catcher	14
Stop switch	15
Stop switch – resistance measurement	15
Choke control	16
Throttle trigger	17
Hand grip heater	18
Starter assembly	20
Starter cord	21
Recoil spring	21
Ignition module – testing	22
Ignition module and flywheel	22
Generator	23
Centrifugal clutch	25
Oil pump	27
Carburettor	29
Carburettor – pressure testing	32
Carburettor – adjustment	36
Fuel tank	37
Fuel filter	38
Fuel hose	38
Piston and cylinder	40
Decompression valve – pressure testing	41
Cylinder – pressure testing	43
Crankcase and crankshaft	43
Crankshaft bearings	44
Repairing damaged threads	46
Guide bar bolts	46
Appendix A, Carburettor – EPA models	47

Introduction

Arrangement of the manual

This workshop manual can be used in two different ways.

- To repair a specific sub-assembly on a chainsaw.
- To dismantle and reassemble a complete chainsaw.

Repairing a specific sub-assembly

If a specific sub-assembly on the chainsaw needs to be repaired:

1. Look up the page referring to the relevant sub-assembly.
2. Follow the instructions under the headings:
 - Removal/Dismantling
 - Cleaning and inspection
 - Refitting/Reassembly

Dismantling and reassembling the entire chainsaw

If the entire chainsaw is to be dismantled, follow the instructions under the heading "Removal/Dismantling".

Work through the manual and follow the instructions given in each section under the heading "Removal/Dismantling".

Then follow all the "Cleaning and inspection" instructions in each section.

Working from the back of the manual, follow all the instructions under the headings "Refitting/Reassembly" in reverse order.

Each of the sections covering removal/dismantling and refitting/reassembly include the relevant lubrication instructions and bolt torques for each stage of repair.

Construction and function

This chapter gives a simple description of the chainsaw carburettor and its various parts.

Troubleshooting

These pages describe the most common faults that affect a chainsaw. They are divided into four different groups with the most likely faults described first.

Repair instructions

The section that describes how to repair the chainsaw consists of detailed, step-by-step instructions. It explains in detail the special tools, lubricants and bolt torques that are needed when working on each component.

This workshop manual covers the following chainsaw models:

**357XP/G
359/G**

Safety regulations

General instructions

This workshop manual gives detailed instructions on how to troubleshoot, repair and test a chainsaw. This section also describes the various safety precautions that should be taken when carrying out repairs.

The workshop manual has been written for personnel who are assumed to have general experience of repairing and servicing chainsaws.

Workshops where chainsaws are repaired must be equipped with safety equipment that meets local regulations.

No-one should carry out repairs on a chainsaw until they have read and understood the contents of this workshop manual.

Chainsaws are type-approved to meet the relevant safety legislation, but this only applies when the saw is fitted with the cutting equipment specified in the user's manual. The fitting of any other equipment, or of accessories or parts that are not approved by Jonsered, could mean that the saw no longer meets these safety requirements and the person who carried out the work may be held responsible for its non-conformance.

In this workshop manual the following boxes indicate where caution should be taken.



WARNING!
The warning text warns of the risk of personal injury if the instructions are not followed.

NOTE!

The warning text warns of the risk of material damage if the instructions are not followed.

Special instructions

The fuel that is used in a chainsaw poses the following hazards:

- The fuel and its fumes are toxic.
- May cause irritation to skin or eyes.
- May cause breathing difficulties.
- Highly flammable.

When using compressed air the air jet should never be pointed at the body. Air can be forced into the bloodstream and cause fatal injury.

Wear ear protection when testing saws.

After testing a saw do not touch the silencer until it has cooled down. The silencer gets very hot and you may burn yourself. Wear protective gloves when working on the silencer.

The guide bar, chain and clutch cover (chain brake) must be fitted before the saw is started. If not, the clutch may come loose and cause injury.

Poor chain lubrication can result in failure of the chain, which could cause serious or fatal injury.

Take care to ensure that the spring inside the starter assembly does not fly out and cause injury. Wear eye protection. If the spring is under compression when the pulley is removed it could fly out and cause injury.

Before removing the tensioning spring from the chain brake, ensure that the brake is in the on position, otherwise the spring may fly out and cause injury.

After repair, the chain brake must be checked as described in the section "Chain brake – operating test".

Always consider the fire risk. A chainsaw can produce sparks that could start a fire.

Inspect the chain catcher and replace it if it is damaged.

Special tools

1

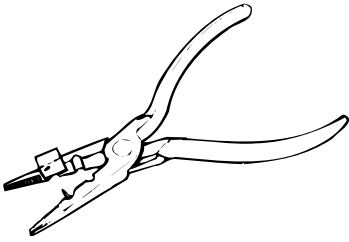

2

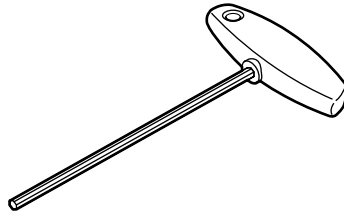

3

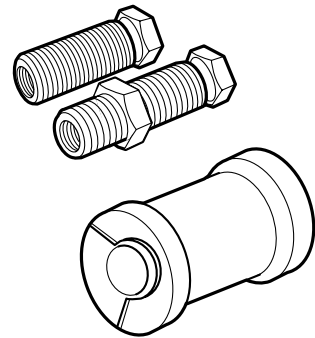

4

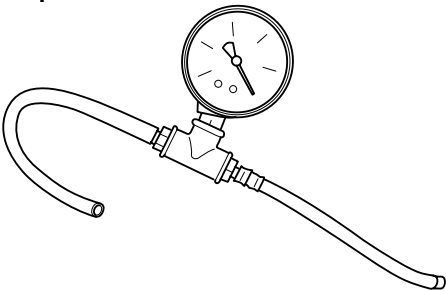

5

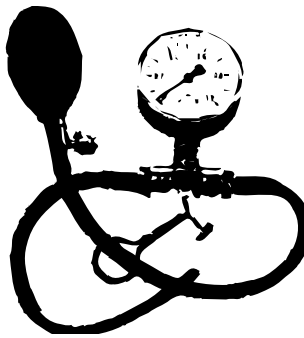

6

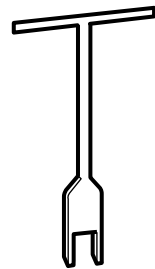

7

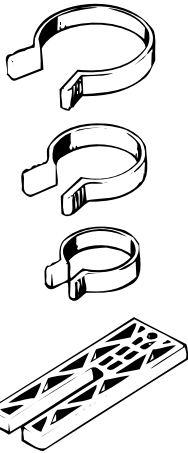

8

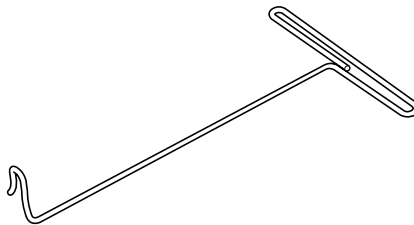

9

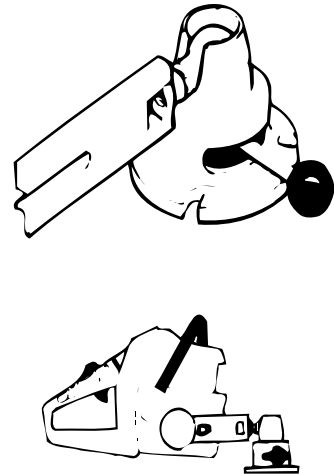

10

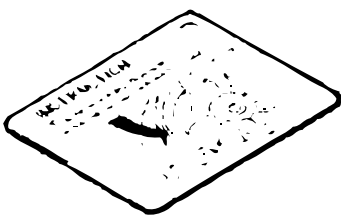

11

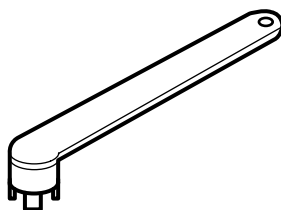

12

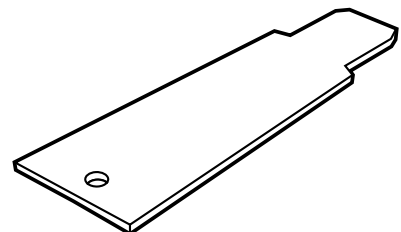

13

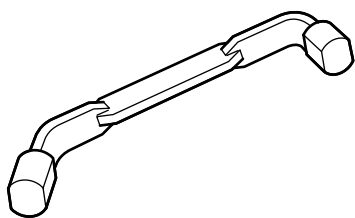

14

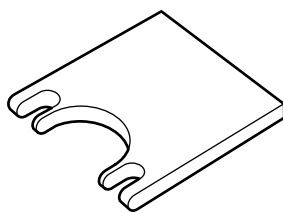

15

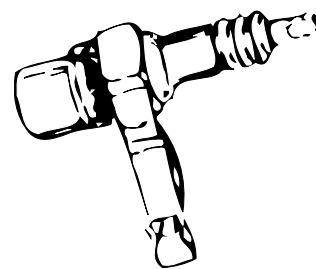

16

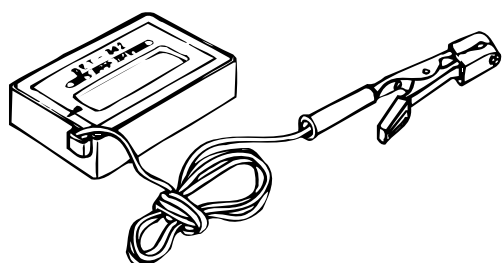

17

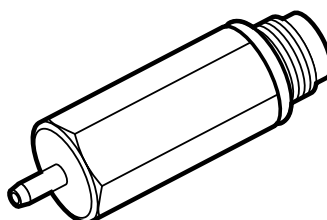

18

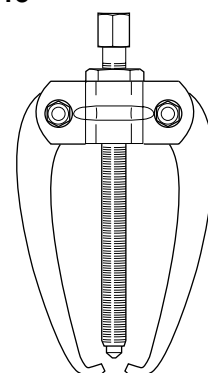

Item	Description	Used for	Order no.
1	Assembly pliers	Fitting spark plug guard	502 50 06-01
2	Allen key	For M5 bolts	502 50 18-01
3	Crankshaft tool	Fitting crankshaft seal	502 50 30-16
4	Vacuum gauge	Vacuum test	502 50 37-01
5	Pressure gauge	Pressurisation during testing	502 50 38-01
6	Fork	Fitting clutch spring	502 50 67-01
7	Piston fitting kit	Fitting piston	502 50 70-01
8	Fuel filter hook	Withdrawing the fuel	502 50 83-01
9	Clamp stand	Clamping the saw	502 51 02-01
10	Feeler gauge	Adjusting ignition module	502 51 34-02
11	Clutch tool	Centrifugal clutch	502 52 22-02
12	Cover plate	Sealing during pressure testing	502 54 11-02
13	Piston stop	Locking crankshaft	502 54 15-01
14	Stop plate	Locating intake gaiter	502 54 17-01
15	Test plug	Checking ignition module	502 71 13-01
16	Rev counter	Adjusting carburettor	502 71 14-01
17	Pressure tester	Connection to cylinder	503 84 40-02
18	Puller	Frame bearing	504 90 90-02

Technical data



Displacement
cm³/cubic inches

357XP:
359:

57 / 3,5
59 / 3,6

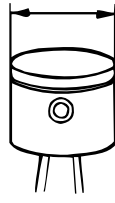

Cylinder bore
Ø mm/Ø inches

46,0 / 1,81
47,0 / 1,85

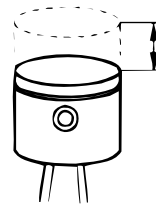

Stroke
mm/inches

34,0 / 1,34
34,0 / 1,34

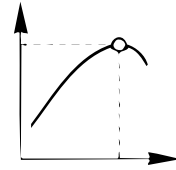

Max power/speed
kW/hp/rpm

3,2 / 9 600
2,9 / 9 000

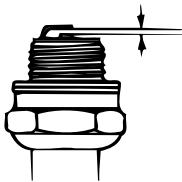

Spark plug gap
mm/inches

357XP:
359:

0,5 / 0,02
0,5 / 0,02

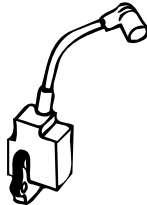

Ignition system

FHP ET
FHP ET

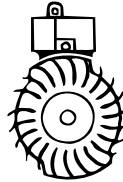

Air gap
mm/inches

0,3 / 0,012
0,3 / 0,012



Carburettor type

Walbro HDA 174
(EPA) Walbro HDA 175
Walbro HDA 174
(EPA) Walbro HDA 175

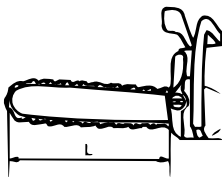

Effective cutting length
cm/inches

357XP:
359:

33-61 / 13-24
31-58 / 13-24



Chain speed at
max power – revs
m/s – rpm

21,4 / 9 600
20,1 / 9 000

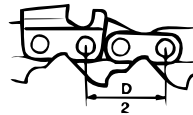

Chain pitch
mm/inches

8,25 / 0,325/ 9,52/3/8
8,25 / 0,325/ 9,52/3/8

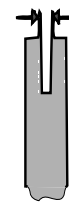

Drive link
mm/inches

1,5 / 0,058
1,5 / 0,058

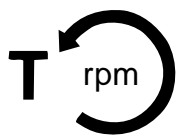

Idling speed
rpm

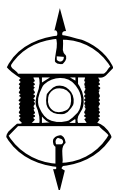

Engagement speed
rpm

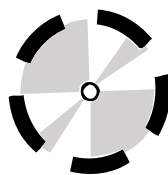

Max. speed
rpm



Spark plug

357XP:	2 700	3 800	14 000	Bosch RCJ 7Y, NGK BPMR 7A
359:	2 700	3 800	13 500	Bosch RCJ 7Y, NGK BPMR 7A



Fuel tank capacity
Litres/US pints

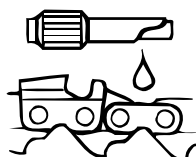

Oil pump capacity at
8,500 rpm,
ml/min



Oil tank capacity
Litres/US pints

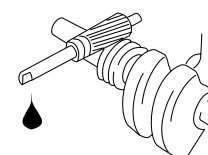

Automatic oil pump

357XP:	0,68 / 1,44	5 - 15	0,38 / 0,80	Yes
359:	0,68 / 1,44	5 - 15	0,38 / 0,80	Yes

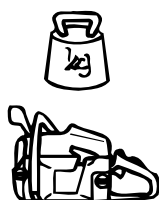

Weight without bar and chain
kg / lbs



Weight with bar and chain
kg / lbs



Heated hand grips

357XP:	5,5 / 12,1	6,3 / 13,9	-
357XPG:	5,6 / 12,4	6,4 / 14,1	Yes
359:	5,5 / 12,1	6,3 / 13,9	-
359G:	5,6 / 12,4	6,4 / 14,1	Yes

Construction and function

Carburettor

The carburettor consists of three sub-systems:

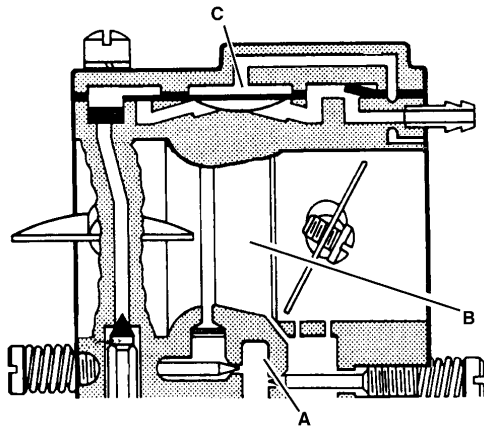

- The **metering unit** (A) which contains the jets and the fuel control mechanism. This measures out the right amount of fuel to suit the speed of the saw and the power demand.
- The **mixing unit** (B) consists of the choke, diffuser jets and throttle valve. This is where the air and fuel are mixed to create a flammable mixture.
- The **pump unit** (C) pumps fuel from the tank to the metering system inside the carburettor. One side of the pump diaphragm is connected to the crankcase and pulses as a result of pressure changes in the crankcase. The other side of the diaphragm sucks in the fuel.

The carburettor works in different ways depending on the setting:

- Cold start mode
- Idling mode
- Part throttle mode
- Full throttle mode

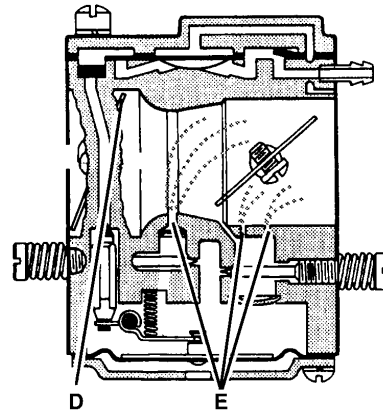

In the cold start mode the choke valve (D) is completely closed. This increases the vacuum in the carburettor so that fuel is sucked through the diffuser jets faster (E).

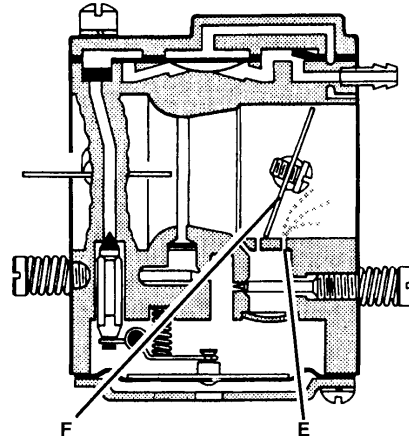

In idling mode the throttle valve (F) is closed. Air is sucked through an aperture in the throttle valve and a small amount of fuel is supplied through the diffuser jet (E).

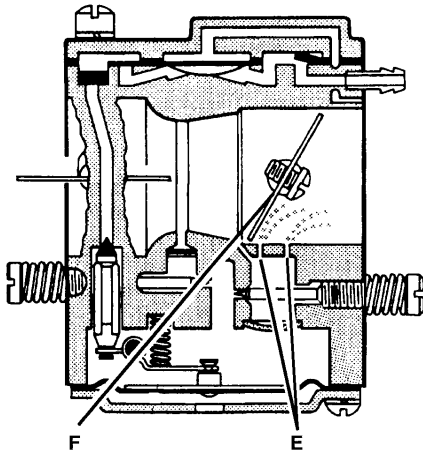

In part throttle mode the throttle valve (F) is partially open. Fuel is supplied through the diffuser jets (E).

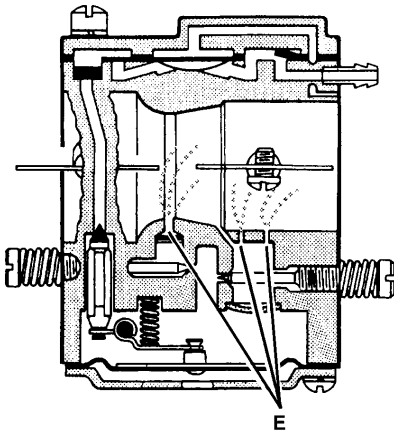

In full throttle mode both valves are open and fuel is supplied through all the diffuser jets (E).

Troubleshooting

The various faults that can affect a chainsaw are divided into four groups. In each group the likely symptoms are given on the left and possible causes are listed on the right. The most likely faults are given first, and so on.

Starting

Difficulty starting	Adjust L screw Air filter blocked Choke not working Worn choke pivot Worn choke valve Fuel filter blocked Fuel line blocked Piston ring seized Blocked impulse channel
Carburettor leaking fuel	Loose or faulty fuel pipe Hole in diaphragm Worn needle valve Needle valve assembly sticking Needle valve set too high Leak in metering system (air or fuel) Loose cover on carburettor pump side
Flooding when engine not running	Worn needle valve Needle valve set too high Needle valve assembly sticking

Idling (low rpm)

Will not idle	Adjust L screw Leaking air intake hose (rubber) Loose carburettor mounting bolts Loose or faulty fuel hose Fuel filter blocked Fuel line blocked Fuel tank vent blocked Throttle valve pivot stiff Throttle pushrod sticking Defective throttle return spring Bent throttle stop Faulty diffuser jet
Idling too rich	Adjust L screw Worn needle valve Needle valve set too high Worn needle valve lever Leaking control diaphragm/cover plate Needle valve assembly sticking

Idling (low rpm) (cont.)

Idles when L screw closed	Worn needle valve Leaking control diaphragm/cover plate Needle valve assembly sticking Worn needle valve lever Faulty diffuser jet
Idling uneven	Fuel filter blocked Fuel line blocked Leaking air intake hose (rubber) Loose carburettor mounting bolts Worn throttle valve pivot Loose throttle valve screw Worn throttle valve Needle valve assembly sticking Leak in metering system (air or fuel) Metering system centre knob is worn Hole in diaphragm Leaking control diaphragm/cover plate Crankcase leaking
L screw requires constant adjustment	Fuel line blocked Needle valve set too high Needle valve assembly sticking Leak in metering system (air or fuel) Leaking control diaphragm/cover plate Faulty diffuser jets Crankcase leaking
Too much fuel at idling	Needle valve set too high Needle valve assembly sticking Metering system damaged Worn needle valve Leaking control diaphragm/cover plate Metering system incorrectly assembled

High rpm

Will not run at full throttle	Adjust H screw Blocked air filter Blocked fuel tank vent Blocked fuel filter Fuel line blocked Loose or damaged fuel hose Impulse channel leaking Impulse channel blocked Loose cover on carburettor pump side Faulty pump diaphragm Leaking air intake hose (rubber) Loose carburettor mounting bolts Needle valve set too low Metering system damaged Metering system incorrectly assembled Leaking control diaphragm/cover plate Needle valve assembly sticking Blocked silencer
Low power	Adjust H screw Blocked fuel tank vent Blocked fuel filter Impulse channel leaking Impulse channel blocked Loose cover on carburettor pump side Faulty pump diaphragm Blocked air filter Needle valve assembly sticking Leak in metering system (air or fuel) Metering system incorrectly assembled Loose diaphragm rivet Hole in diaphragm Leaking control diaphragm/cover plate
Will not "four-stroke"	Blocked fuel tank vent Blocked fuel filter Fuel line blocked Loose or damaged fuel hose Impulse channel leaking Impulse channel blocked Loose cover on carburettor pump side Faulty pump diaphragm Leaking air intake hose (rubber) Loose carburettor mounting bolts Needle valve set too low Leak in metering system (air or fuel) Metering unit incorrectly assembled Loose diaphragm rivet Hole in diaphragm Leaking control diaphragm/cover plate

Acceleration and retardation

Does not accelerate	Adjust L screw Adjust H screw Blocked air filter Blocked fuel tank vent Blocked fuel filter Fuel line blocked Loose or damaged fuel hose Impulse channel blocked Loose cover on carburettor pump side Faulty pump diaphragm Leaking air intake hose (rubber) Loose carburettor mounting bolts Needle valve set too low Metering system incorrectly assembled Needle valve assembly sticking Faulty diffuser jets Blocked silencer
Engine stalls when throttle released	Adjust L screw Adjust H screw Faulty pump diaphragm Needle valve set too high Needle valve assembly sticking Faulty diffuser jets
Over rich acceleration	Adjust L screw Adjust H screw Blocked air filter Faulty pump diaphragm Faulty diffuser jets

Troubleshooting methods

In addition to the faults described in the above table, trouble shooting can be carried out on specific components or sub-systems of the chainsaw. The various procedures are described in the relevant sections, as follows:

- Checking the operation of the chain brake Page 13
- Measuring the resistance of the stop plate Page 15
- Pressure testing the carburettor Page 32
- Pressure testing the decompression valve Page 41
- Pressure testing the cylinder Page 43

Repair instructions

Chain brake – dismantling

1

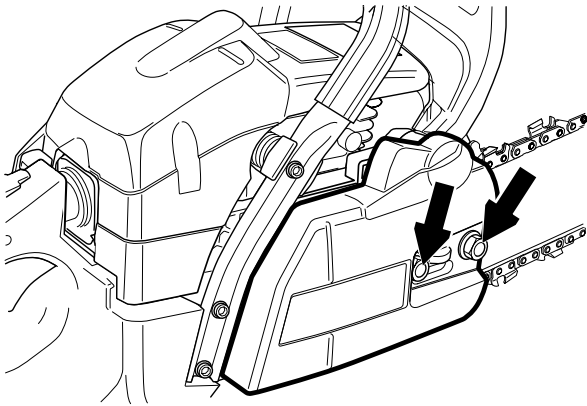

Disengage the brake by pushing the kickback guard backwards. Unscrew the guide bar bolts and remove the clutch cover, chain and guide bar.

2

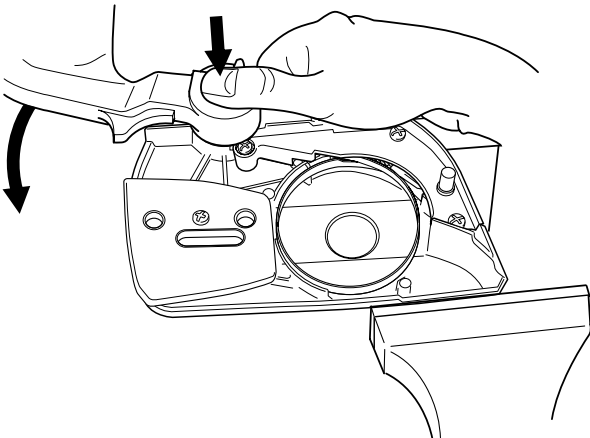

Grip the clutch cover carefully in a vice. Release the brake spring by using the kickback guard from the saw as a tool. Engage it with the brake mechanism and turn anticlockwise to activate the brake.

3



WARNING!
Make sure the spring does not fly out and cause injury. Wear eye protection.

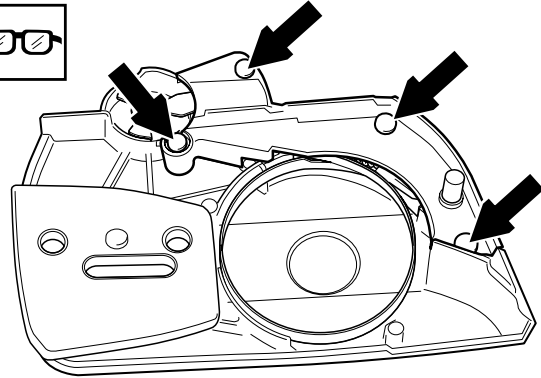

Remove the screws and carefully remove the cover from the chain brake spring.

4

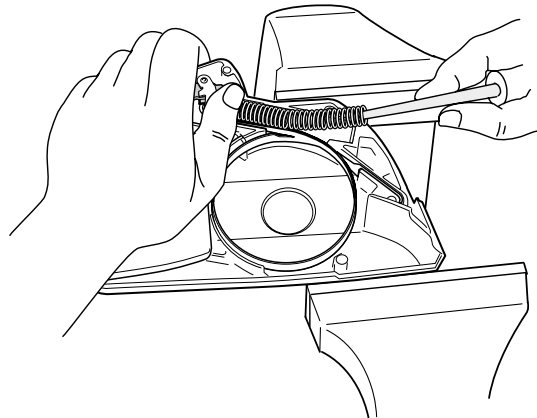

Place one hand over the brake spring and insert a small screwdriver between the rear end of the spring and the clutch cover. Carefully prise the spring upwards to release it and slide it onto the screwdriver shaft. Release the locking washer from the elbow joint and lift it off.

Cleaning and inspection

- Clean and inspect all parts carefully. If there are any cracks or other defects replace the damaged parts with new ones. Always use original parts.
- Measure the thickness of the chain brake band. It must be no less than 0.6 mm at any point.
- Lubricate the elbow joint with grease.

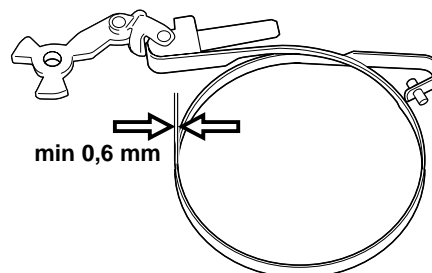

Chain brake – reassembly

1

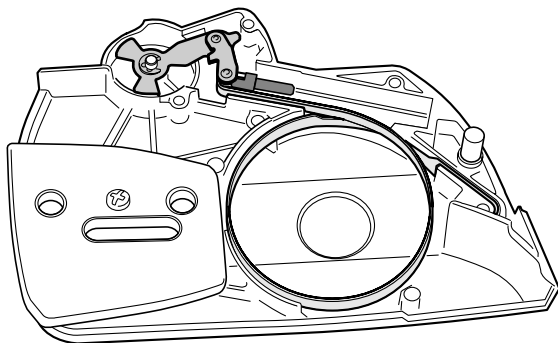

Bolt the elbow joint to the brake band and tighten to a torque of 1–1.5 Nm. Locate the elbow joint and connected brake band in their recesses in the clutch cover. Lubricate the recess for the spring with grease.

2



WARNING!
Make sure the spring does not fly out and cause injury. Wear eye protection.

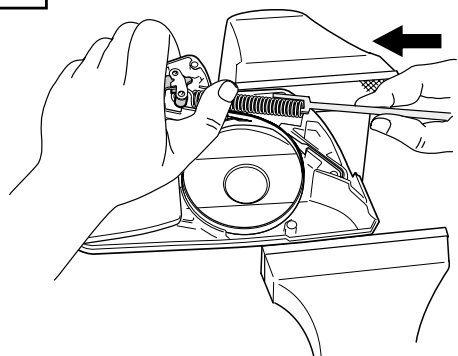

Grip the clutch cover in a vice. Compress the spring with special tool 502 50 67-01 and push it down with your thumb.

3

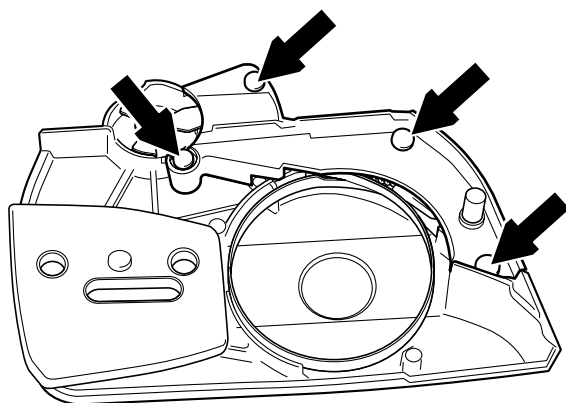

Fit the cover over the chain brake spring, tightening the screws to a torque of 1–1.5 Nm.

4

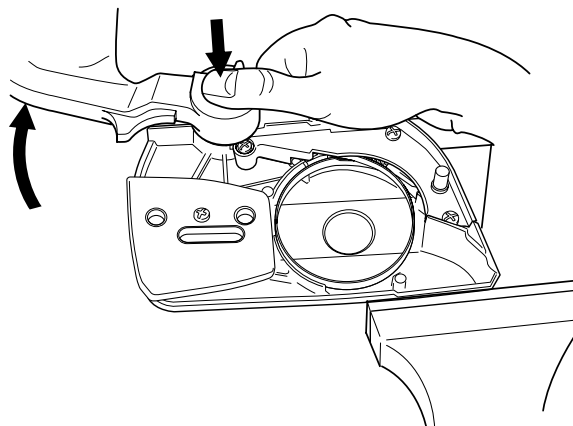

Tension the brake spring by using the kickback guard from the saw as a tool. Engage it with the brake mechanism and turn clockwise to release the brake.

5

Turn the chain tensioner anticlockwise as far as it will go.

Refit:

- guide bar
- chain
- clutch cover

NOTE!

After completing the repair the chain brake must be tested as described below.

Operating test:

The engine must not be running during the test.

Guide bar length	Height
38cm/15"	50 cm/20"

- Hold the chainsaw over a firm surface. The height of the guide bar above the surface is given in the table above.
- Let go of the front handle and let the chainsaw fall towards the surface.
- When the guide bar hits the surface the chain brake must engage.

Silencer – removal



WARNING!
Do not touch the silencer until it has cooled down, otherwise you may burn yourself.

1

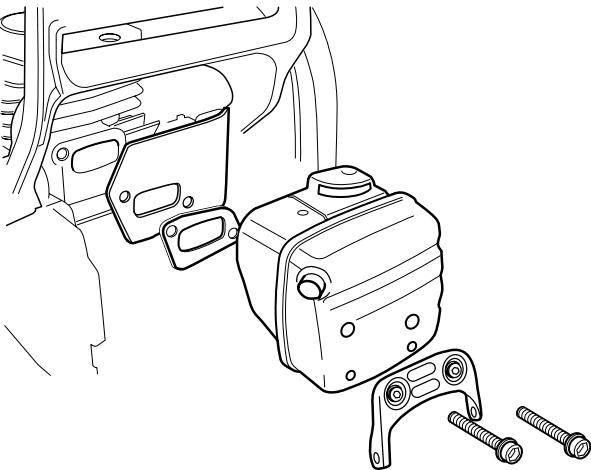

Remove the cylinder cover, silencer support, silencer, gasket and cooling plate.

In order to remove the silencer support you must first remove the top screw from the bark rest and partially undo the bottom screw.

2

If the saw is fitted with a spark arrestor mesh this must also be removed.

Cleaning and inspection

Clean and inspect all parts carefully. If there are any cracks or other defects replace the damaged parts with new ones.

The spark arrestor mesh is best cleaned with a wire brush. If the mesh is damaged it must be replaced.

If the mesh is blocked the saw will overheat and this will cause damage to cylinder and piston. Never use the saw with a silencer that is in poor condition. Always use original parts.

Silencer – refitting

1

If the saw is equipped with a spark arrestor mesh this should be fitted first.

2

Refit

- cooling plate
- gasket
- silencer, tighten bolts to a torque of 12–14 Nm
- silencer support, tighten bolts to a torque of 8–10 Nm
- bark rest, tighten bolts to a torque of 8–10 Nm
- cylinder cover

3

Run the saw for at least 1 minute, then retighten the silencer bolts to 8–10 Nm.

Chain catcher – replacement

If the chain catcher is worn it must be replaced with a new one.

1

Release the brake by pushing the kickback guard backwards. Undo the guide bar bolts and remove the clutch cover, chain and guide bar.

2

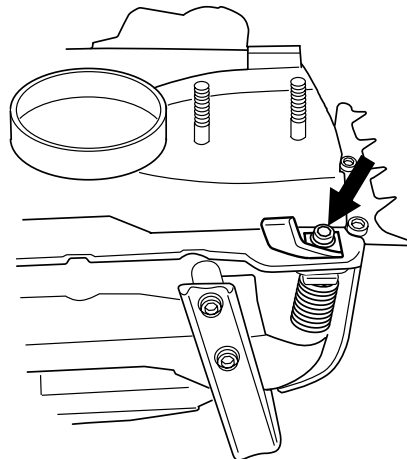

Remove the chain catcher and replace it with a new one, tightening the bolts to 4–5 Nm. Check that the vibration damping spring locates correctly against the crankcase when you bolt the new chain catcher in position.

3

Turn the chain tensioner anticlockwise as far as it will go.

Refit:

- guide bar
- chain
- clutch cover

Stop switch – removal

1
Remove the cylinder cover.

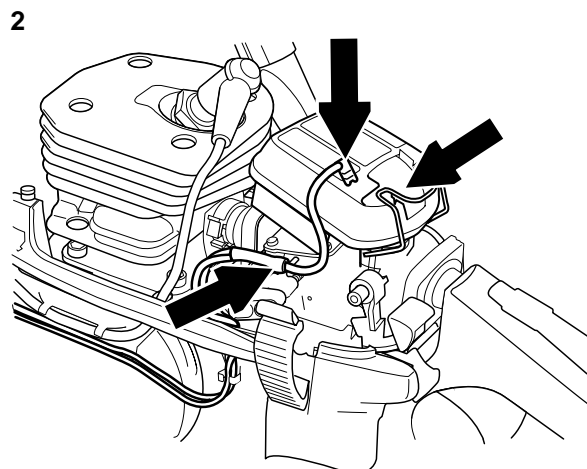

Release the clip and remove the air filter. Disconnect both leads from the stop plate and stop switch.

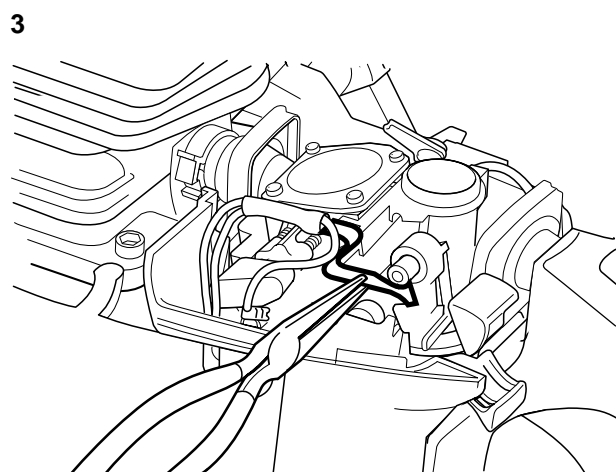

Remove the stop plate by carefully sliding it over the lug on the front mounting.

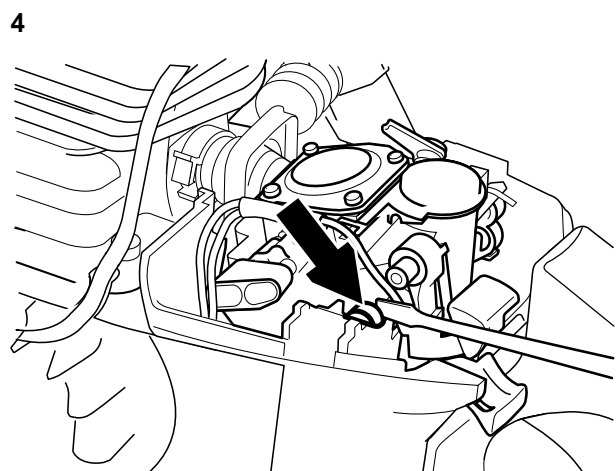

Carefully prise the carburettor assembly off the left-hand rubber mounting using a small screwdriver.

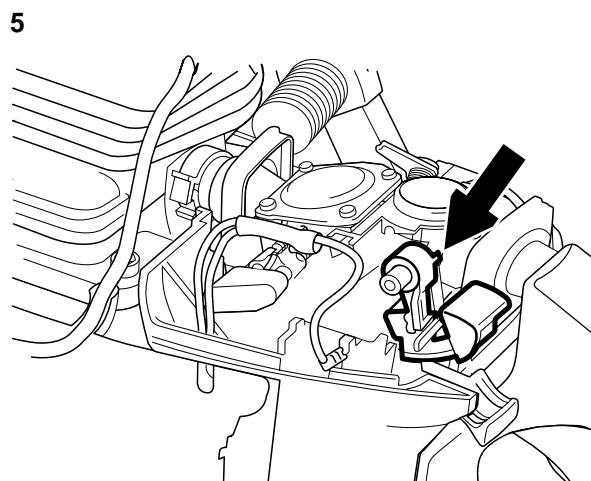

Carefully prise the stop switch's upper mounting off the air filter holder while lifting the switch to release it from the lower mounting.

Cleaning and inspection

Clean and inspect all parts carefully. If there are any cracks or other defects replace the damaged parts with new ones. Always use original parts.

Stop switch – resistance measurement

Remove the cylinder cover and starter assembly. Clean the mating surfaces and check the resistance as follows:

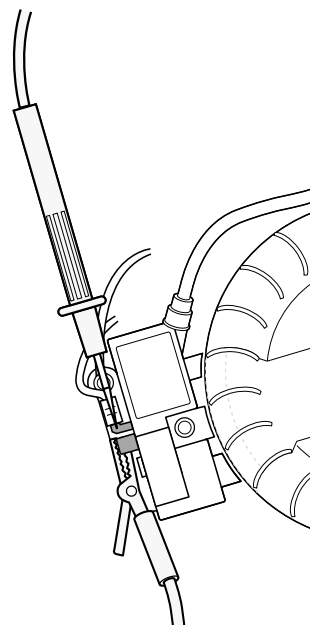

Measure the resistance by connecting a multimeter to the ignition coil. **NOTE!** The switch must be in the "on" position to give the correct reading.

The resistance must not be higher than 0.2 ohm when the switch is in the on position.

Stop switch – refitting

1

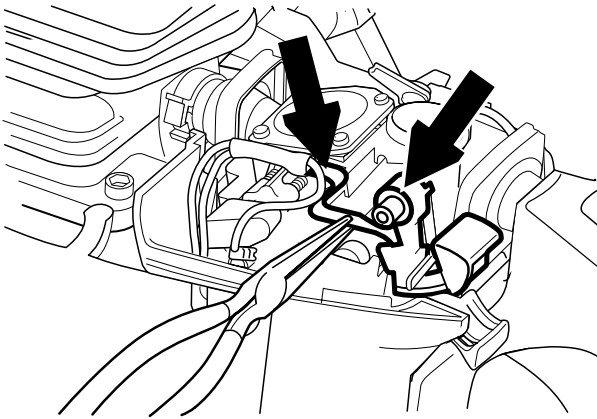

Carefully press the new stop switch into place. Check that the switch's upper mounting clips over the air filter holder.

2

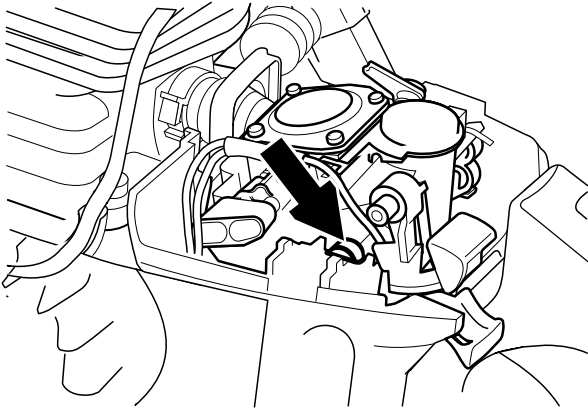

Push the carburettor gently back into the left-hand rubber mounting.

3

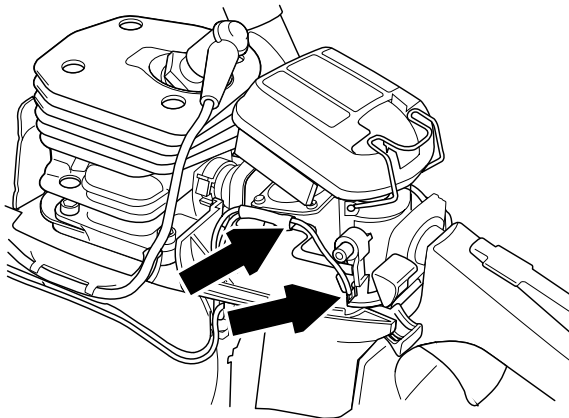

Reconnect the lead to the stop plate and stop switch. Refit the air filter and secure it with the clip.

4

Refit the cylinder cover.

Choke control – removal

1

Remove the cylinder cover, air filter and stop switch. Disconnect the fuel hose from the carburettor.

NOTE!

Do not use knurled pliers to disconnect or reconnect the fuel hose. This could damage the hose and lead to leakage or fracture.

2

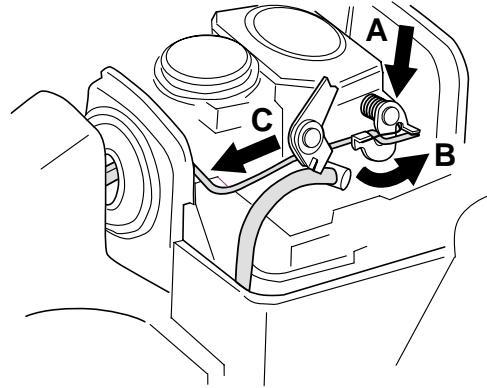

Disconnect the pushrod from the carburettor by first carefully prising up the spring over the end of the rod, where it connects to the throttle lever (A). Then press the throttle lever forwards (B) while pressing the throttle pushrod backwards (C) and lifting it off the lever. Withdraw the throttle pushrod from the tank and lift it upwards without pulling it through the rubber inlet manifold. Carefully release the carburettor assembly from the right-hand rubber mounting and lift it upwards.

3

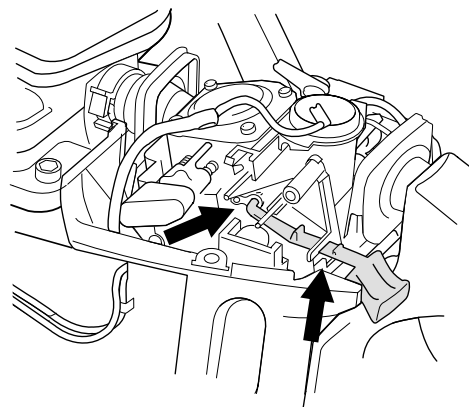

Compress the clip that holds the choke control to the carburettor while pulling it out at the same time. Disconnect the choke control from the air filter holder.

Choke control – refitting

First reattach the choke control to the air filter, then press it onto the carburettor so that the clips engage.

Then refit:

- stop switch
- carburettor into its rubber mountings
- throttle pushrod into the fuel tank and connect to throttle lever.
- lift the spring arm over the throttle pushrod
- fuel hose to the carburettor
- air filter and cylinder cover

Throttle lock, throttle trigger and return spring – removal

1

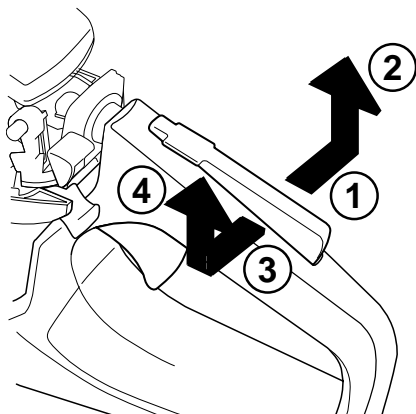

Remove the throttle lock by pressing it to the right and pulling upwards at the same time until you hear a click. Then repeat by pressing it to the left (3) and pulling upwards (4). When both of the lugs on the lock have cleared the tank pull the lock backwards.

2

Drive out the steel pin using a 2.5 mm/0.1" diameter drift. Push it out from the flywheel side of the saw.

3

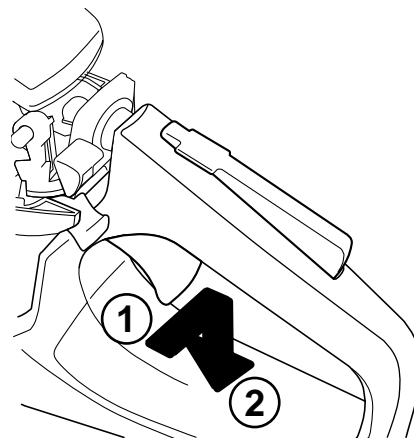

Remove the throttle trigger by first pressing it towards the clutch side of the saw until it clicks, then towards the flywheel side until it clicks again. Remove it from the tank and lift out the return spring.

Cleaning and inspection

- Clean and inspect all parts carefully. If there are any cracks or other defects replace the damaged parts with new ones. Always use original parts.
- Lubricate the throttle lock with oil.
- Check that the spring is not broken and has not lost its tension.

Throttle lock, throttle trigger and return spring – refitting

1

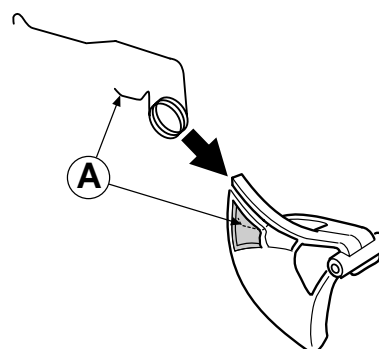

Refit the return spring to the throttle trigger as shown. Make sure the spring is correctly positioned by engaging one end in the slot in the throttle trigger (A).

Press the coil of the return spring into the handle and press the short end of the spring (A) into the recess in the throttle trigger.

2

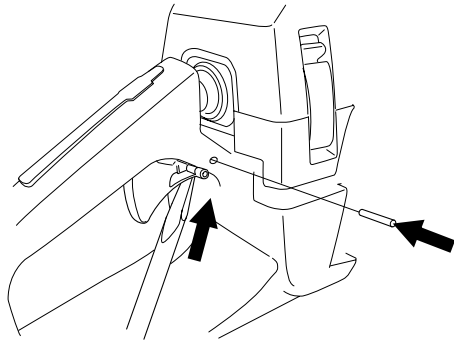

First insert the rear edge of the throttle trigger into the tank. Then push/clip the front edge into the two clips on the tank with the aid of a combination tool, for example. Drive in the steel pin from the clutch side. Use a 2.5 mm/0.1" diameter drift.

3

Then press down the return spring while pressing the throttle lock forwards/upwards into the retaining clip in the fuel tank until you hear a click. Release the return spring in the throttle lock, then press the lock down onto the tank.

4

Check the operation of the throttle lock by trying to press the throttle trigger without pressing down the throttle lock. Also check that the throttle lock and throttle trigger return freely to their original positions when released.

Hand grip heater on model 357XP/G and 359/G – removal

No heating or heating only in front hand grip

• Front hand grip – troubleshooting

1

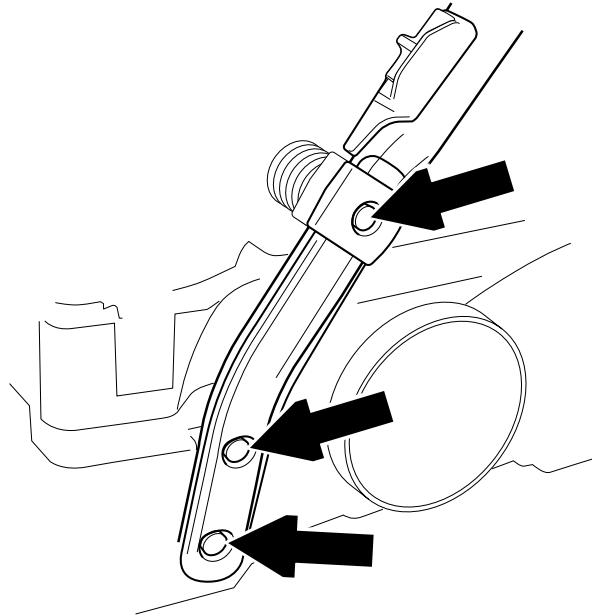

Remove the three bolts that secure the cover over the front hand grip. Disconnect the leads from the switch and generator and measure the resistance of the hand grip heater, which should be 3–4 ohm. Replace the front hand grip if the resistance is higher.

2

Reconnect the leads and secure the cover back in place over the front hand grip.

• Generator – troubleshooting

1

Remove the cylinder cover and cover from the front hand grip. Disconnect the black lead from the generator and connect a multimeter between it and a clean area on the cylinder. The multimeter should show a resistance of 0.9–1.3 ohm. If higher or lower, replace the generator, see "Replacing the generator".

2

Reconnect the lead and refit the hand grip cover and cylinder cover.

• Switch – troubleshooting

1

Carefully free the switch and frame from the front hand grip using a screwdriver.

2

Disconnect the leads from the switch and connect a multimeter to it. The meter should read over 1000 ohm when the switch is in the "0" position. The meter should read no higher than 0.1 ohm with the switch in the "1" position. Replace the meter if the readings are outside these limits.

Rear hand grip heater not working

• Rear hand grip heater – troubleshooting

1

Remove the cylinder cover, air filter and cover from the rear hand grip.

2

Remove the throttle pushrod, see "Carburettor – removal".

3

Remove the bolt from the plate at the base of the carburettor to release the lead for the heater element.

4

Disconnect the red lead from the heater element and connect a multimeter between it and the black earth lead that is bolted to the bottom of the carburettor on the clutch side of the saw. The meter should read 0.7–1.2 ohm. If the reading is higher replace the heater element.

Heater element and rear hand grip – removal

1

Remove the cylinder cover, hand grip cover, hand grip and right-hand stop.

Then remove:

- throttle lock, throttle trigger and return spring, see "Throttle lock, throttle trigger and return spring - removal"
- fuel hose and throttle pushrod from the carburettor

Unbolt the rear tank mounting from the crankcase, i.e. the rear vibration damping spring, and both stops. Lower the tank as far as it will go to allow access to the heater lead where it is secured to the tank.

Refit:

- fuel tank with both stops (3-4Nm) and the rear vibration damping spring (4-5Nm)
- throttle lock, throttle trigger and return spring, see "Throttle lock, throttle trigger and return spring - removal".
- fuel hose and throttle pushrod to the carburettor (check that the hose is not trapped between the tank and crankcase, measurement 43 mm (1.69 inches))
- hand grip cover, air filter and cylinder cover

Heater element and rear hand grip – removal

1

Screw the heater element into place using the two screws and feed the leads through the rear hand grip. Secure the red lead in the clip on the tank and connect it. Feed the black lead through crankcase and secure/earth it to the base of the carburettor using the bolt at the front on the clutch side of the saw. Tighten to a torque of 3–4 Nm.

2

Refit:

- fuel tank with both stops (3-4Nm) and the rear vibration damping spring (4-5Nm)
- throttle lock, throttle trigger and return spring, see "Throttle lock, throttle trigger and return spring - removal".
- fuel hose and throttle pushrod to the carburettor (check that the hose is not trapped between the tank and crankcase, measurement 43 mm (1.69 inches))
- hand grip cover, air filter and cylinder cover

Hand grip heater on model 357XP/G and 359/G – refitting

1

Feed the leads into the rear hand grip and insert the heater element in the hand grip. Screw in the two bolts through the right side of the hand grip to secure the heater.

2

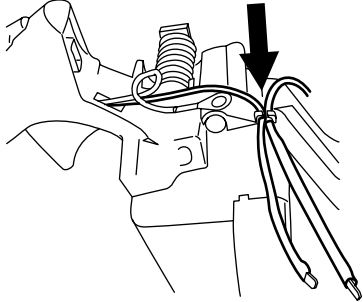

Press the black lead into the base of the carburettor and connect it with the bolt. Tighten to a torque of 3–4 Nm.

3

Run the red lead to the front hand grip and connect it.

4

Refit the throttle trigger and throttle lock and check that they work correctly, see "Throttle lock, throttle trigger and return spring - removal".

5

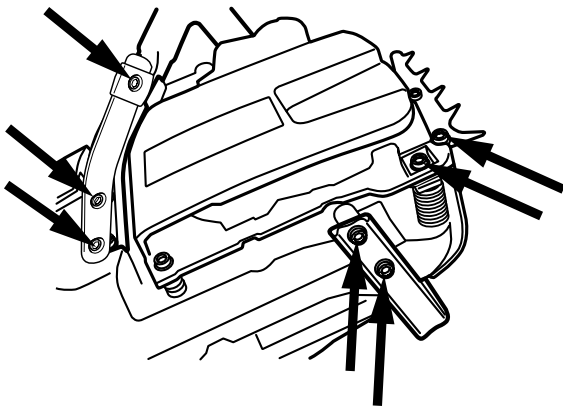

Bolt the vibration damping springs that hold the tank unit back in place and refit the cover over the front hand grip. Tighten to a torque of 4–5 Nm.

Starter assembly – removal

1

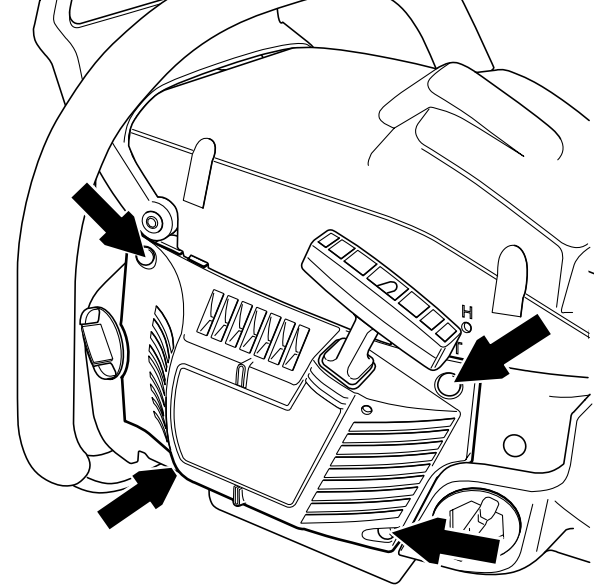

Undo the four bolts that fasten the starter assembly to the crankcase and lift off the starter assembly.

2

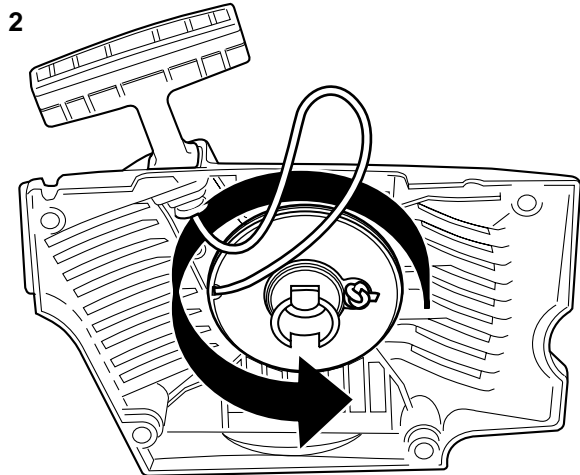

Pull out about 30 cm of the cord and fasten it in the notch in the pulley rim. Release the tension in the return spring by letting the pulley wind backwards slowly.

3



WARNING!

If the recoil spring is still under tension when the pulley is removed it can fly out and cause injury. Wear eye protection.



Remove the bolt from the centre of the pulley and lift off the pulley.

Cleaning and inspection

Clean the parts and check the following:

- The starter cord.
- The teeth on the pulley, lubricate with oil.
- That the pawls on the flywheel are undamaged, i.e. that they spring back towards the centre and move freely.
- Lubricate the return spring with light oil.

Replacing a broken or worn starter cord

1

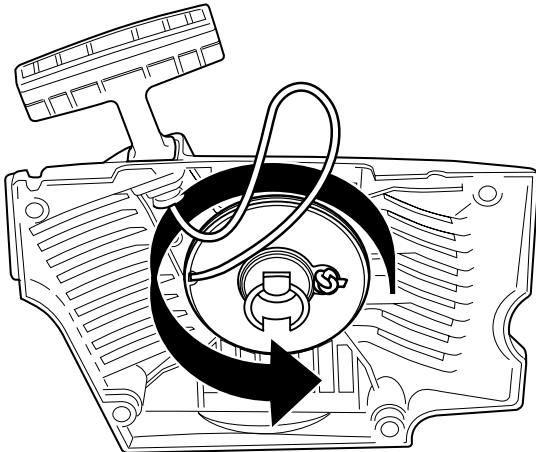

Before replacing a worn starter cord the tension in the recoil spring must be released. Pull the starter cord out through the notch in the pulley rim and wind the pulley anti-clockwise to release the tension in the spring.

2

Remove the bolt from the centre of the pulley and lift off the pulley.

3

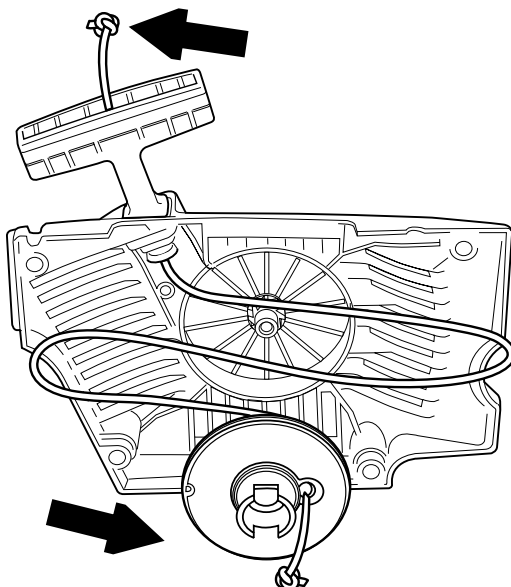

Fit a new cord through the hole in the pulley and tie a knot to secure it. Feed the other end of the cord through the hole in the starter housing and through the starter handle, then tie a double knot in the end. Wind about 3 turns of the starter cord onto the pulley. Fit the bolt through the centre of the pulley and tighten to a torque of 2–3 Nm.

Cleaning and inspection:

- Clean and inspect all parts carefully. If there are any cracks or other defects replace the damaged parts with new ones. Lubricate the return spring with light oil.

Tensioning the recoil spring

1

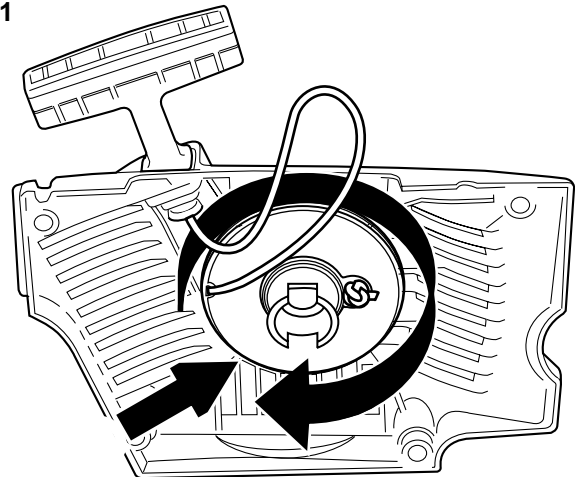

Fasten the starter cord in the notch in the pulley rim and wind the pulley about 2 turns clockwise. Check that the pulley is free to rotate at least another half turn when the starter cord is fully extended.

Replacing a worn recoil spring



WARNING!
Make sure the recoil spring does not fly out and cause injury. Wear eye protection.



1

Remove the bolt from the centre of the pulley and lift off the pulley and spring.

2

Remove the broken recoil spring.

3

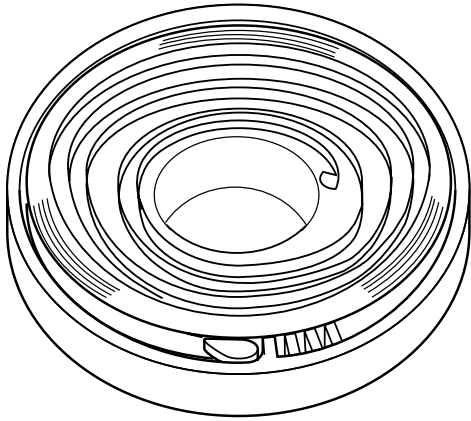

Fit a new recoil spring. Lubricate the recoil spring with light oil.

4

Fit the bolt through the centre of the pulley and tighten to a torque of 2–3 Nm.
Tension the recoil spring, see "Tensioning the recoil spring".

Starter assembly – refitting

1

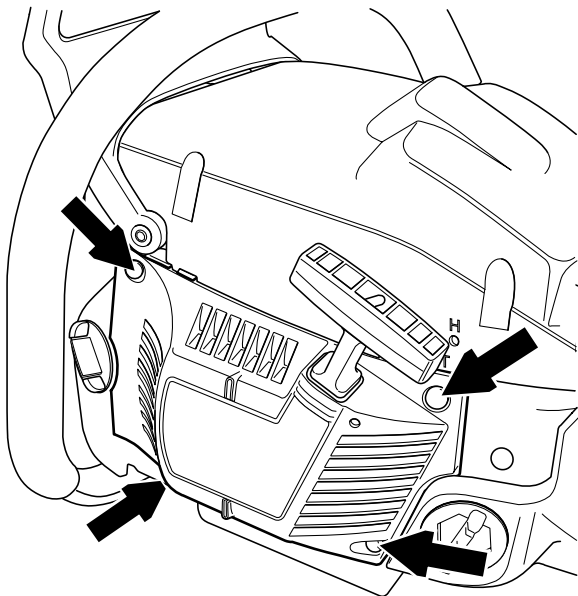

Position the starter assembly on the crankcase and tighten the bolts to a torque of 2.5–3.5 Nm.

Ignition module – testing

If there is a fault in the ignition system the ignition module must be tested before the ignition system is removed.

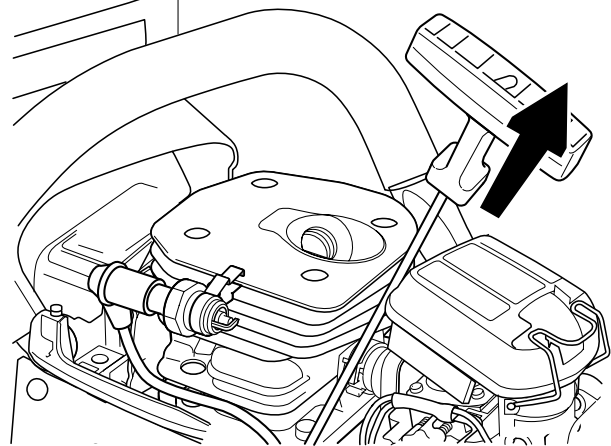

Test the ignition module as follows:

- Connect a test spark plug 502 71 13-01 to the ignition lead and clip the test spark plug onto the cylinder.
- Turn the engine over using the starter cord.
- If the test spark plug produces a spark the ignition module is OK.

Ignition module/flywheel – removal

1

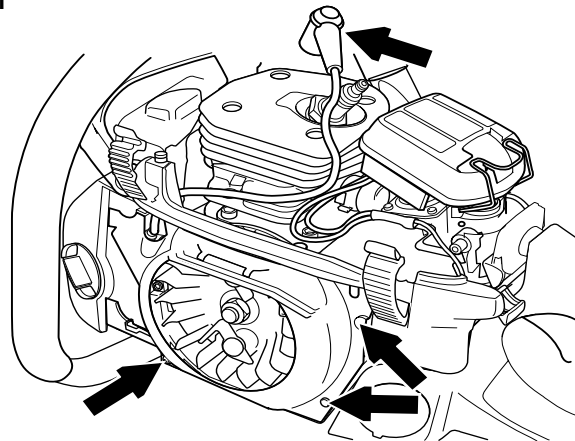

Remove the cylinder cover. Disconnect the HT lead, remove the spark plug and fit piston stop 502 54 15-01 in its place. Take off the starter assembly, release the leads from the cable guide and remove it.

2

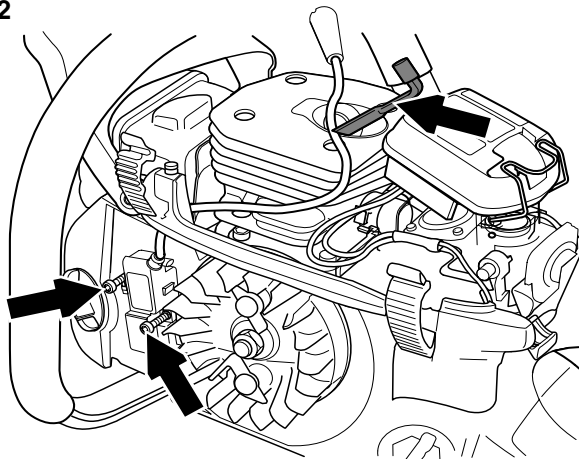

If replacing the ignition module, disconnect its leads and unscrew it. The ignition module can be left in place if you are simply removing the flywheel.

3

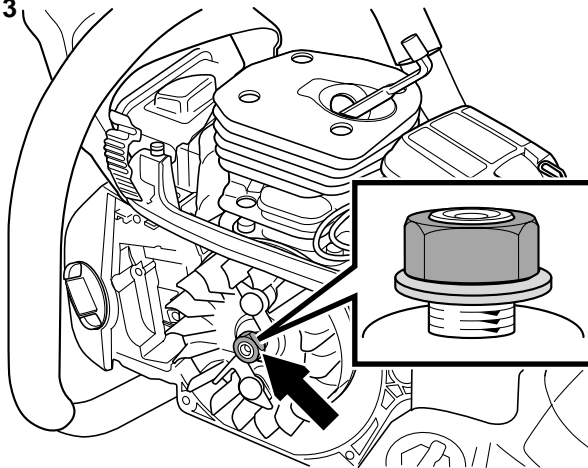

Loosen the flywheel nut using a suitable socket and unscrew it until it is flush with the end of the shaft.

4

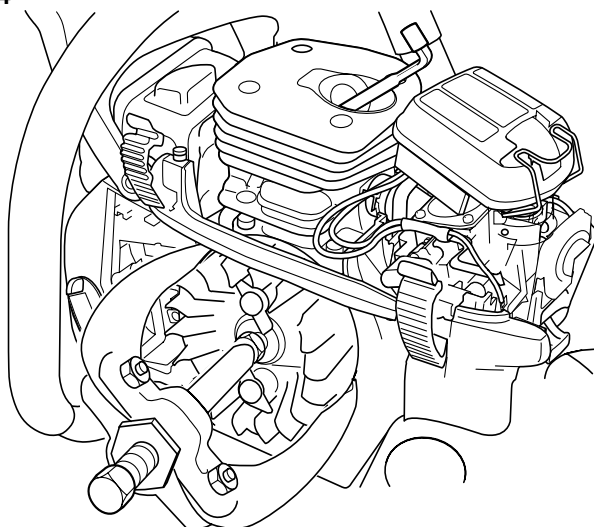

Position puller 504 90 90-02 over the magnets and counterweight on the flywheel. Tighten 2–3 turns and tap the head of the puller with a metal mallet to release the flywheel. Remove the puller, nut and washer. Lift off the flywheel.

Cleaning and inspection

- Clean all parts, especially the tapers on the flywheel and shaft.
- Check that the flywheel is not cracked or damaged in any other way.

Replacing the generator, model 357XP/G and 359/G

1

Remove the cylinder cover. Disconnect the HT lead, remove the spark plug and fit piston stop 502 54 15-01 in its place. Take off the starter assembly, release the leads from the cable guide and remove it. Remove the cover from the hand grip.

2

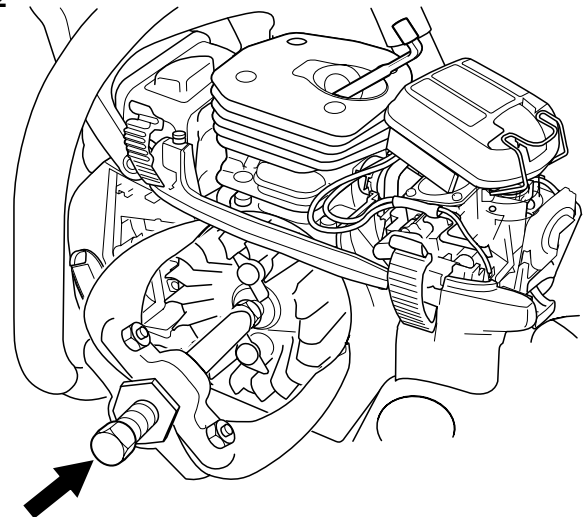

Loosen the flywheel nut using a suitable socket and unscrew it until it is flush with the end of the shaft.

Position puller 504 90 90-02 over the magnets and counterweight on the flywheel. Tighten 2–3 turns and tap the head of the puller with a metal mallet to release the flywheel. Remove the puller, nut and washer. Lift off the flywheel.

3

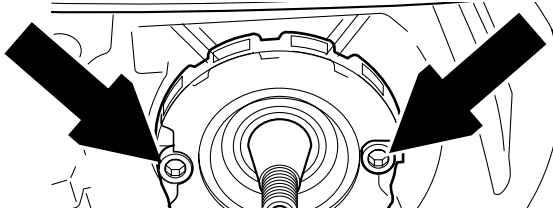

Unscrew the two bolts from the generator but leave the generator in place.

4

Remove the fuel hose and throttle pushrod from the carburettor. Unbolt the rear tank mounting from the crankcase, i.e. the rear vibration damping spring, and both stops. Lower the tank as far as it will go to allow access to the heater lead where it is connected to the tank.

5

Disconnect the generator lead from the hand grip and unclip it from the tank. Remove the generator and lead.

Generator – refitting

1

Feed the generator lead through the holes in the crankcase and hand grip. Bolt the generator in position, tightening the bolts to a torque of 5 Nm. Clip the lead to the tank.
NOTE! The lead connector must be positioned to the right of the clip. Connect the lead to the connector on the hand grip and refit the cover.

2

Refit:

- fuel tank with both stops and rear vibration damping spring
- fuel hose to carburettor, hose length between tank and crankcase: 43 mm (1.69 inches) and between crankcase and carburettor: 53 mm (2.09 inches)
- throttle pushrod to carburettor
- flywheel with nut and washer
- cable guide, leads and starter assembly

Remove the piston stop and reconnect the HT lead and cylinder cover.

Ignition module and flywheel – refitting

1

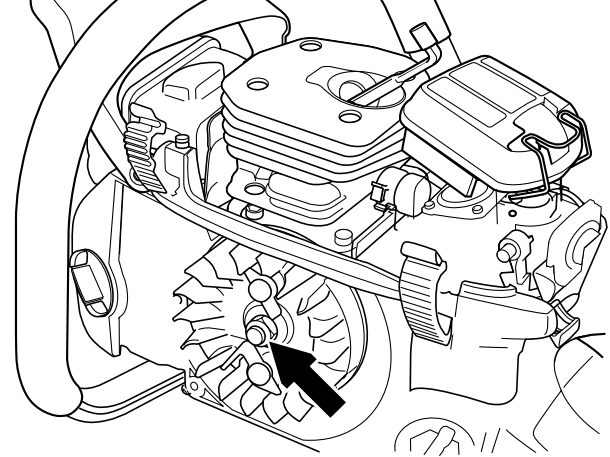

Place the flywheel on the crankshaft. Turn the flywheel so that the key lines up with the keyway in the shaft.

Fit the washer and nut on the shaft and tighten to a torque of 25-30 Nm.

2

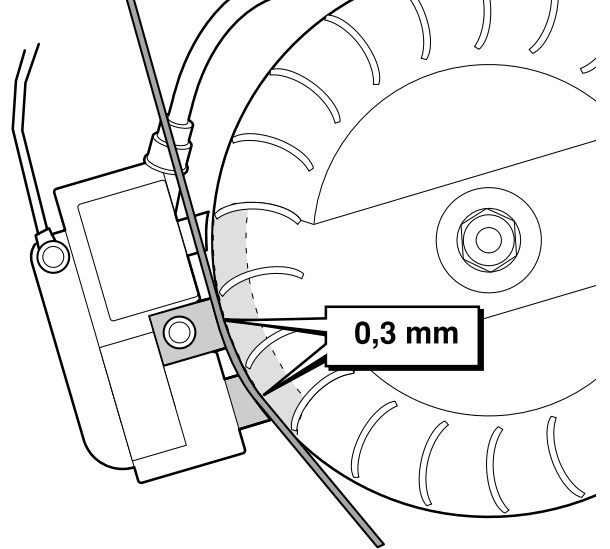

To refit the ignition module proceed as follows:

Turn the flywheel so that the magnets are in line with the ignition module. Fit the ignition module with the plastic feeler gauge (502 51 34-01) held in position at the same time, without tightening the bolts. Connect the black earth lead to the front screw on the ignition module. Adjust the gap between the ignition module and magnet to 0.3 +/- 0.1 mm. The gap must be measured at either of the two lowest pegs on the ignition module. Tighten the bolts to 8-10 Nm. Connect the blue lead to the ignition module.

3

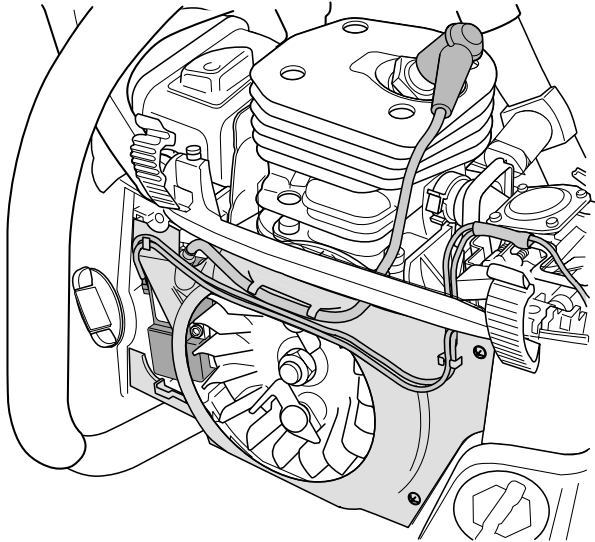

Then refit:

- cable guide and press the leads into position
- HT lead
- starter assembly, tighten to a torque of 2.5–3.5 Nm
- cylinder cover

Centrifugal clutch – removal

1

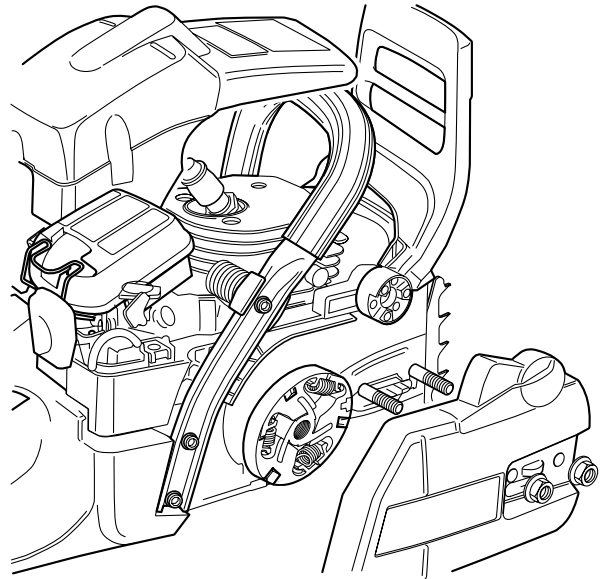

Remove the cylinder cover. Disengage the chain brake by pushing the kickback guard backwards. Undo the guide bar bolts and remove the clutch cover, chain and guide bar.

2

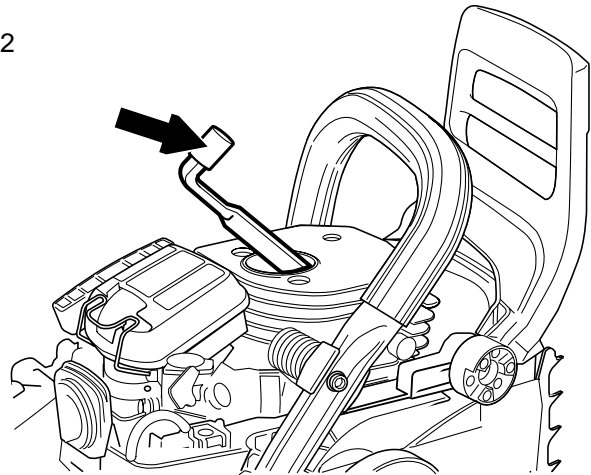

Disconnect the HT lead. Remove the spark plug and fit piston stop 502 54 15-01 in its place.

3

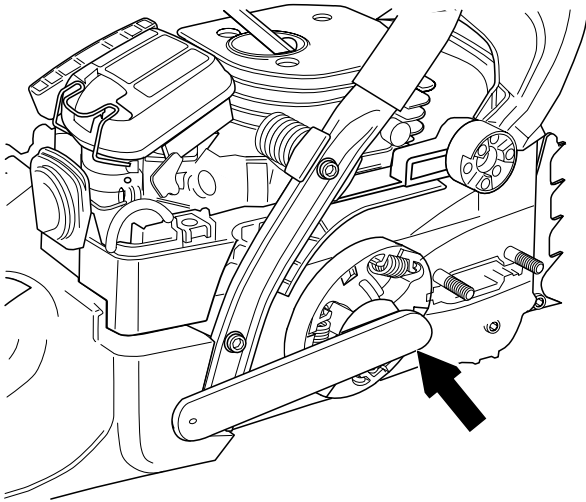

Unbolt the clutch by turning the nut clockwise using tool 502 52 22-02.

4

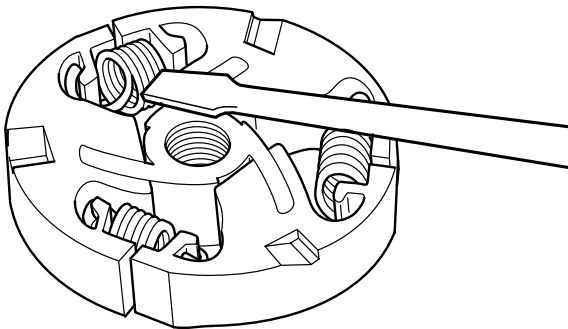

Carefully prise out the clutch springs with a screwdriver.

Inspection and cleaning

- Clean and inspect all parts carefully. If there are any cracks or other defects replace the damaged parts with new ones. Always use original parts.

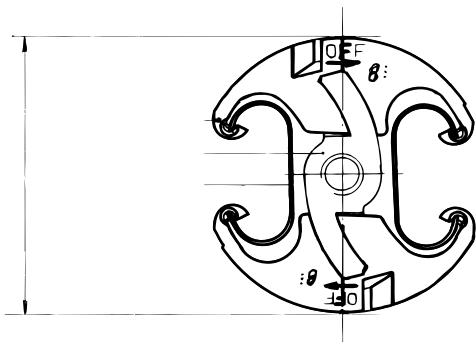

- Check the thickness of the clutch shoes by using vernier callipers to measure the diameter of the clutch. If the diameter is less than 65 mm the clutch assembly must be replaced.

Centrifugal clutch – refitting

1

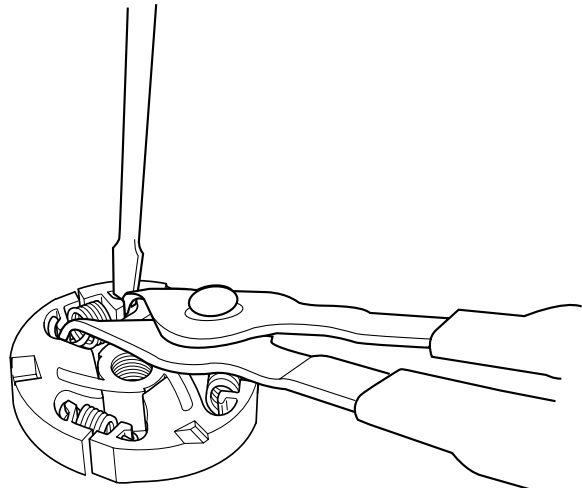

NOTE!

Handle the clutch springs carefully. If they are opened up too much they could damage the saw.

Insert the clutch springs in the shoes using circlip pliers and a screwdriver.

2

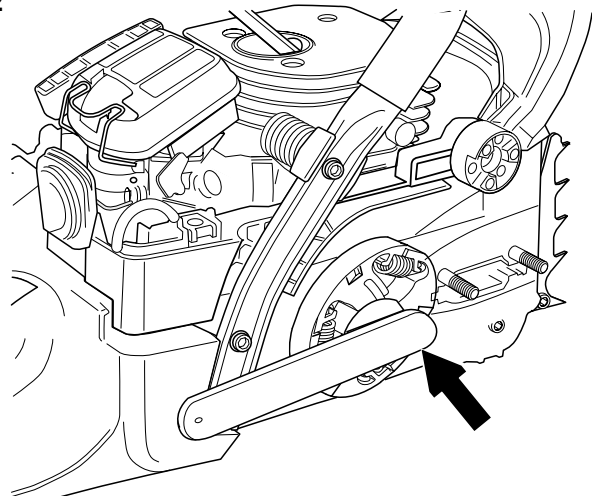

Fit the clutch and tighten anticlockwise as far as it will go. Then tighten to a torque of at least 20 Nm using tool 502 52 22-02.

3

Remove the piston stop. Fit the spark plug, tightening it to a torque of 15 Nm, then connect the HT lead.

Then refit:

- cylinder cover
- guide bar
- chain
- clutch cover

Oil pump – removal

1
Empty and clean the oil tank.

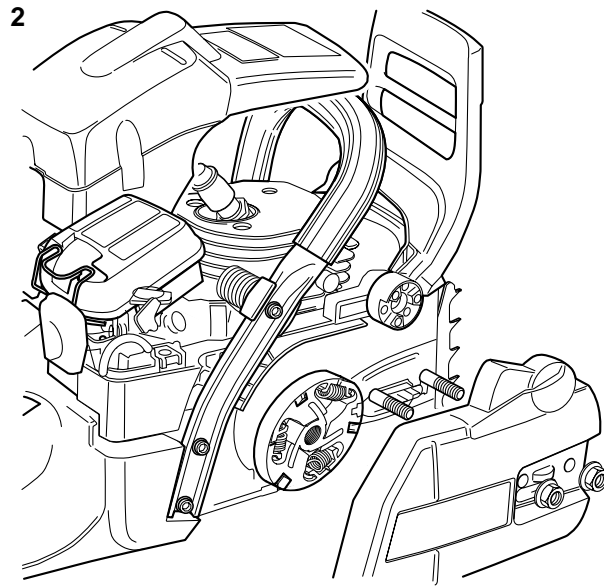

Remove the cylinder cover. Disengage the chain brake by pushing the kickback guard backwards. Undo the guide bar bolts and remove the clutch cover, chain and guide bar. Disconnect the HT lead. Remove the spark plug and fit piston stop 502 54 15-01 in its place. Unbolt the clutch using tool 502 52 22-02 and a suitable socket or combination spanner. Turn the nut clockwise to remove it.

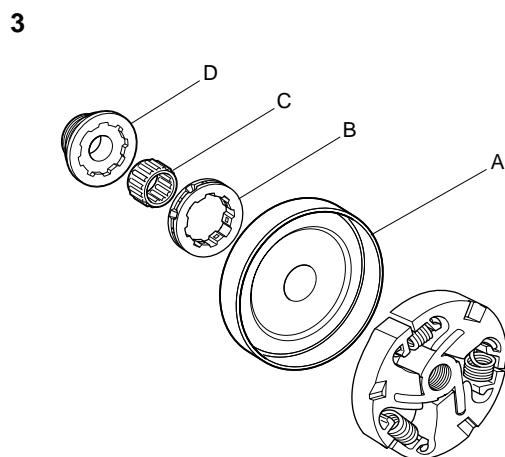

Unbolt and remove the clutch drum (A), chain sprocket (B), needle bearing (C) and pump drive wheel (D).

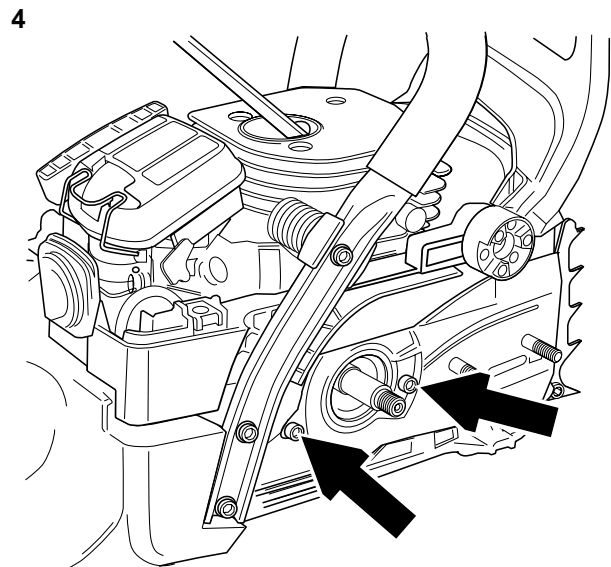

Remove the chain guide plate.

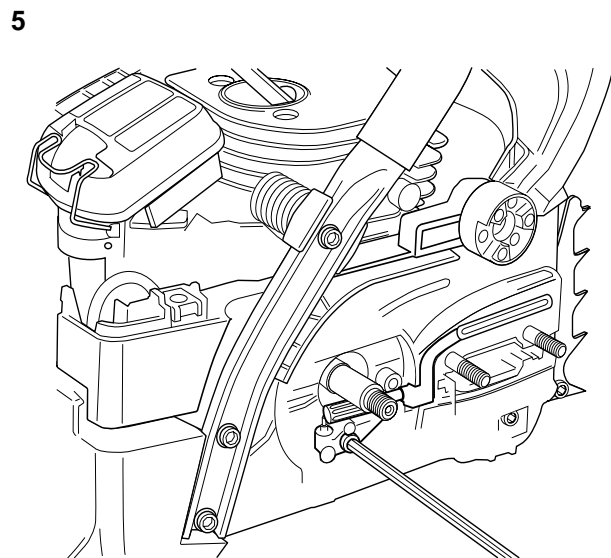

Unbolt the oil pump from the crankcase.

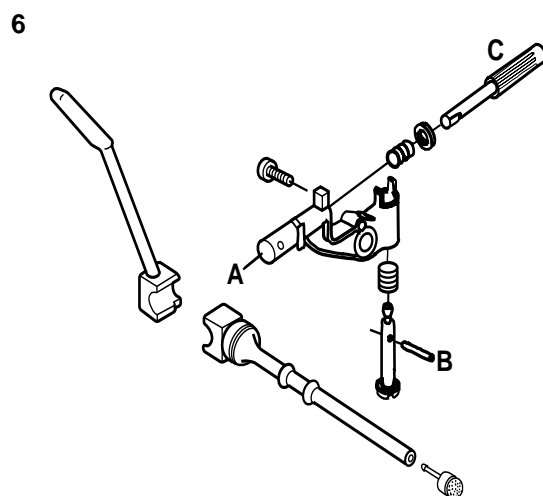

Remove the oil hose and filter (A).

7

Remove the pin (B) from the adjuster screw, using a small drift to press it out.

8

Press in the pump piston (C) so that the adjuster screw (D) can be removed. Remove the pump piston.

Cleaning and inspection

- Clean and inspect all parts carefully. If there are any cracks or other defects replace the damaged parts with new ones. Always use original parts.
- Lubricate all moving parts with grease

Oil pump –refitting

1

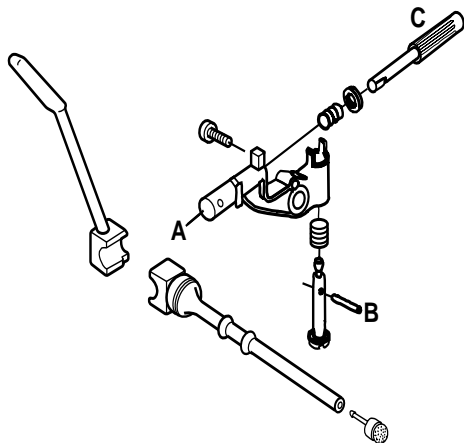

Lubricate the pump piston (C) with grease and fit the pump piston and washers.

2

Press down the pump piston (C). Fit the adjuster screw and spring so that the pin (B) can be pressed into position.

3

Reconnect the oil hose and filter (A).



WARNING!
Poor chain lubrication can result in failure of the chain, which could cause serious or fatal injury.

4

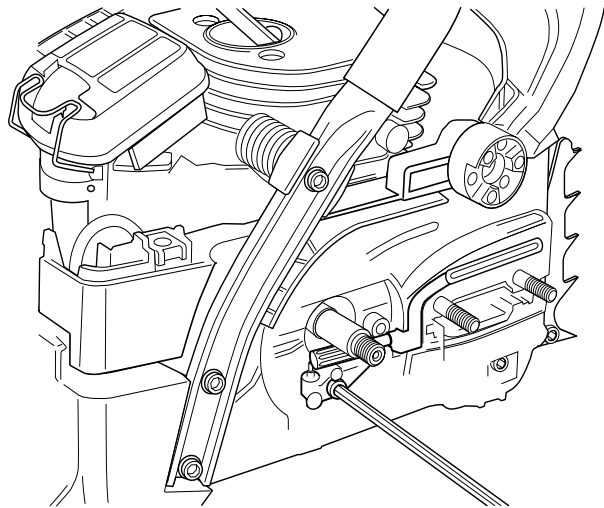

Refit the oil pump, tightening the bolts to a torque of 3–4 Nm.

5

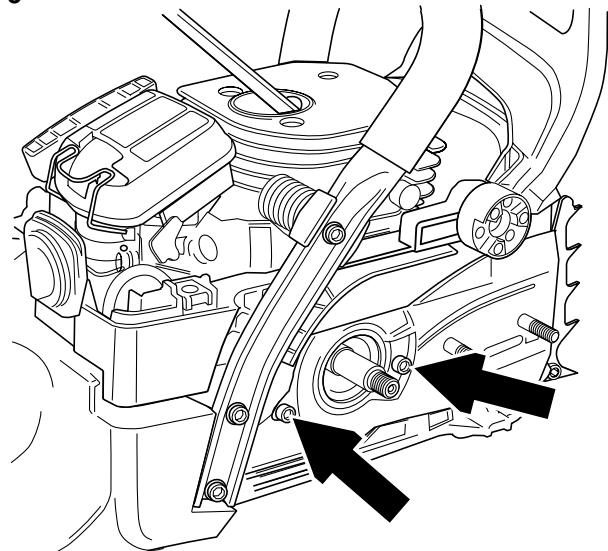

Fit the chain guard plate, tightening the bolts to a torque of 2–3 Nm.

6

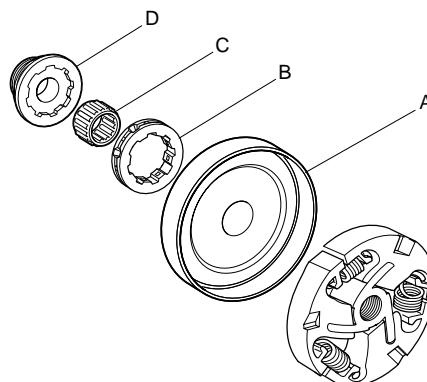

Lubricate the needle bearing with grease. Fit the pump drive wheel (D), needle bearing (C), chain sprocket (B), if fitted, and clutch drum (A).

7

Fit the clutch and tighten anticlockwise as far as it will go. Then tighten to a torque of at least 20 Nm using tool 502 52 22-02.

8

Remove the piston stop. Fit the spark plug, tightening it to a torque of 15 Nm, then connect the HT lead. Then refit the cylinder cover, guide bar, chain and clutch cover.

9

Refill the tank with oil. For more information see the user instructions for this model for the recommended grade of oil.

Adjustable oil pump – adjustment

Use a screwdriver or adjustable spanner to turn the adjuster screw on the pump. Turning the screw clockwise decreases the oil flow and turning it anticlockwise increases the oil flow.

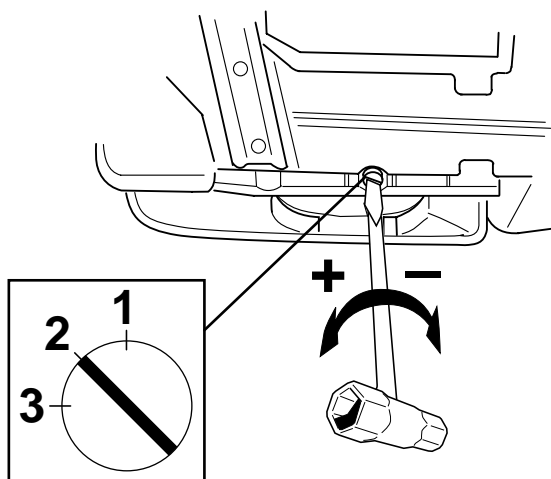

Recommended setting:

13–15" bar Min. setting
 15–18" bar Midway setting
 18–20" bar Max. setting

Carburettor – removal

1

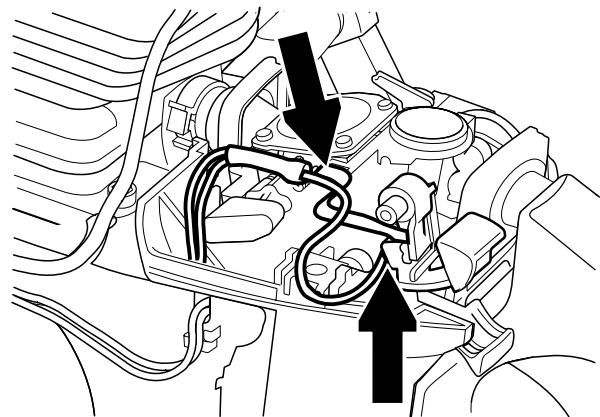

Remove the cylinder cover and air filter. Disconnect the leads from the stop switch.

2

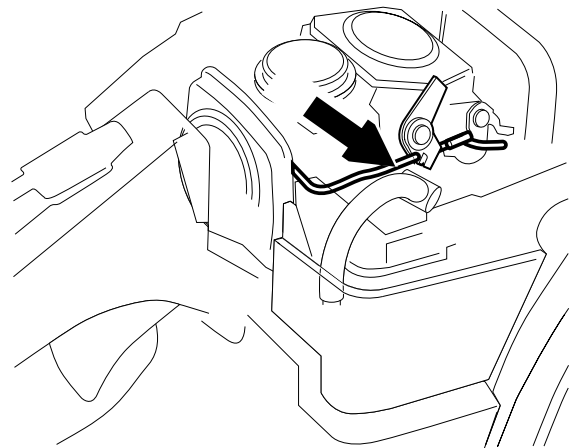

Disconnect the throttle pushrod from the carburettor by first carefully prising up the spring over the end of the rod where it connects to the throttle lever. Then press the throttle lever forwards while pressing the throttle pushrod backwards and lifting it off the lever. Withdraw the throttle pushrod from the tank and lift it upwards without pulling it through the rubber inlet manifold. Carefully release the carburettor assembly from its rubber mountings.

3

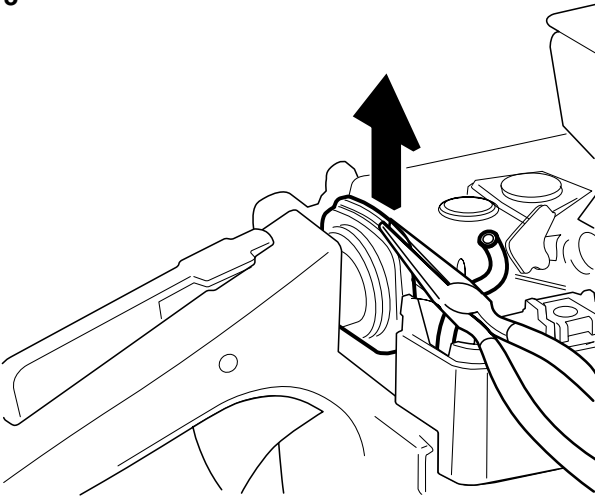

NOTE!

Do not use knurled pliers to disconnect or reconnect the fuel hose. This could damage the hose and lead to leakage or fracture.

Disconnect the fuel hose from the carburettor. Remove the rubber inlet manifold, using pliers to lift it upwards.

4

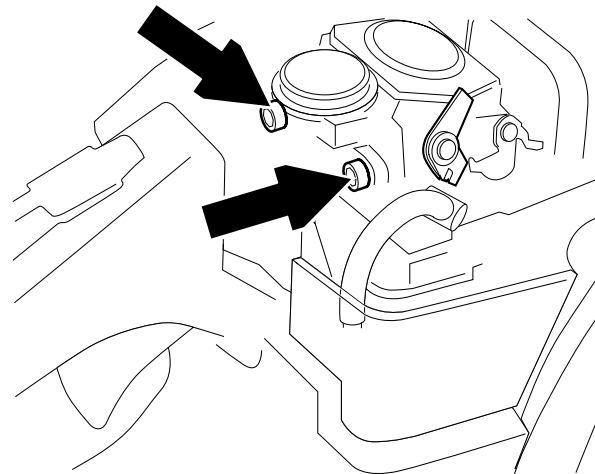

Undo and remove the carburettor bolts. Lift off the carburettor.

Carburettor – dismantling

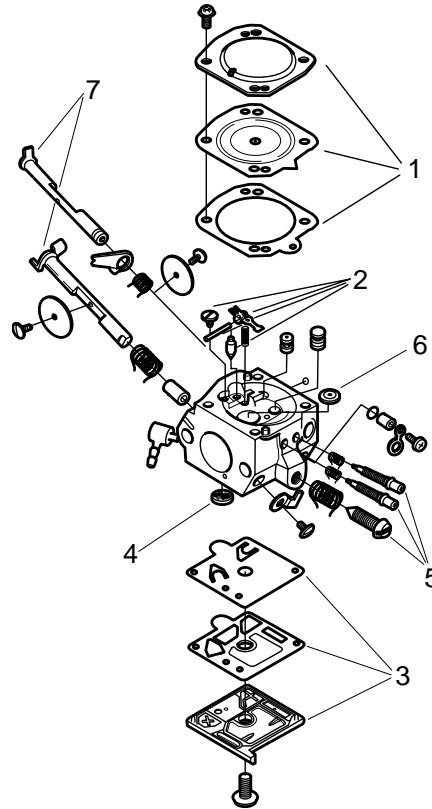

The item numbers in the diagram refer to the steps below (1–7).

- 1** Remove the cover from the metering unit and carefully remove the metering diaphragm and gasket.
- 2** Undo the screw and take out the needle valve, together with the lever arm, spindle and spring.
- 3** Remove the cover from the pump unit and carefully remove the gasket and pump diaphragm.
- 4** Remove the fuel filter.
- 5** Remove the high, low and idling jet screws. (HDA 159A high and low jet screws are protected by plastic caps which can be prised off with a screwdriver. Only on EPA, see appendix A.)
- 6** Remove the plug by first drilling a hole in it and then prising it out with a screwdriver or the like.
- 7** If necessary remove the throttle and choke valves, and remove the spindles together with the lever arms and springs.

Cleaning and inspection

Clean all the carburettor components in petrol. Use an airline to dry off the petrol from all components. Blow through all the channels in the carburettor body and check that they are not blocked.

Check that:

- The gasket, pump diaphragm and metering diaphragm are undamaged.
- There is no play in the throttle and choke valves.

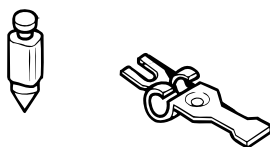

- The needle valve and its lever arm are not worn.
- The fuel filter is undamaged.
- The tips of the high and low speed jet screws are not damaged.
- The air intake duct is not cracked.

Carburettor – reassembly

NOTE!

Cleanliness is very important when reassembling the carburettor. Tiny particles of dirt can cause operating problems.

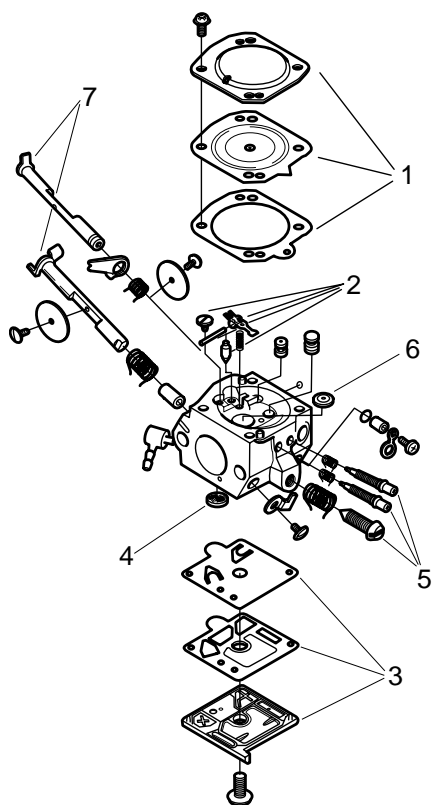

The item numbers in the diagram refer to the steps below (1–8).

1

If the throttle and choke butterflies and their spindles were removed, these must be refitted. Lubricate the spindle bearings with light oil.

2

Insert the plug in the hole with the convex side upwards and expand it by pressing downwards with a drift.

3

Refit the high and low speed jet screws and springs, plus the idling screw. Fit the plastic caps over the high and low speed screws.

4

Fit the fuel filter, using the handle of a small screwdriver.

5

Fit the pump diaphragm, gasket and cover to the pump unit.

6

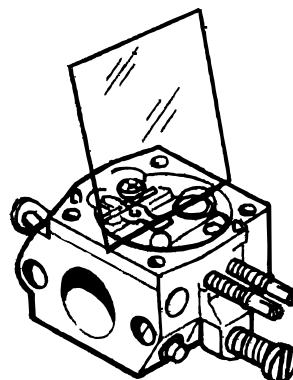

Fit the needle valve with lever arm, spindle and spring and tighten the screw. Use a rule to check that the lever arm is level with the cover face. If necessary, the lever arm can be bent slightly.

7

Fit the metering diaphragm with its gasket and refit the cover to the metering unit.

8

Carry out pressure testing.

Carburettor – pressure testing

Pressure testing should be carried out with the carburettor fully assembled. Testing should always be carried out after the carburettor has been repaired, but can also be performed for troubleshooting before dismantling.

Carry out the test as follows:

- Screw in the high and low speed jet screws and back them off one turn.
- Connect pressure tester 502 50 38-01 to the carburettor fuel inlet.

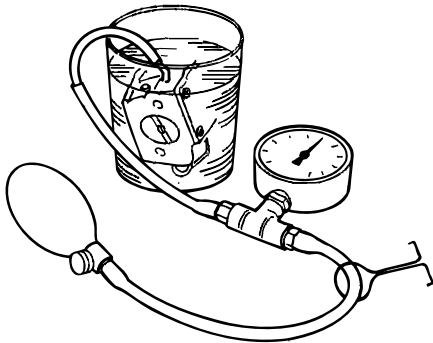

- Lower the carburettor into a beaker of water.
- Pump up the pressure to 50 kPa (0.5 bar) and clamp the pump tube.
- There should be no leakage. If leakage occurs, refer to the table below.

Leakage	Fault lies in
Diffuser jets	Needle valve
In impulse tube	Pump diaphragm
Ventilation hole above metering unit	Control diaphragm

Carburettor – refitting

NOTE!

Cleanliness is very important when reassembling the carburettor. Tiny particles of dirt can cause operating problems.

1

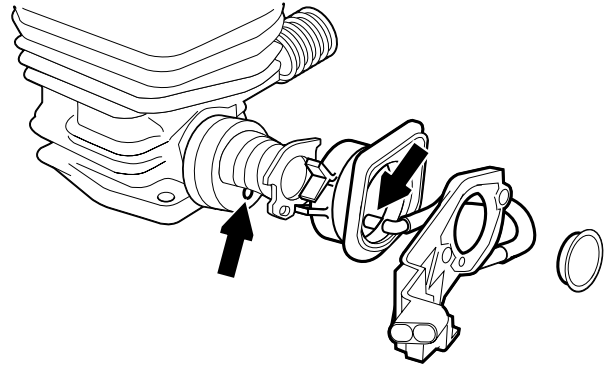

Align the inlet manifold with the cut-out in the carburettor flange and make sure the inlet manifold is correctly seated. It is especially important to ensure that the impulse tube is correctly seated in the impulse channel on the cylinder. In order to check this the cylinder must be removed, see "Piston and cylinder – removal and fitting". Fit the support ring in the inlet manifold.

2

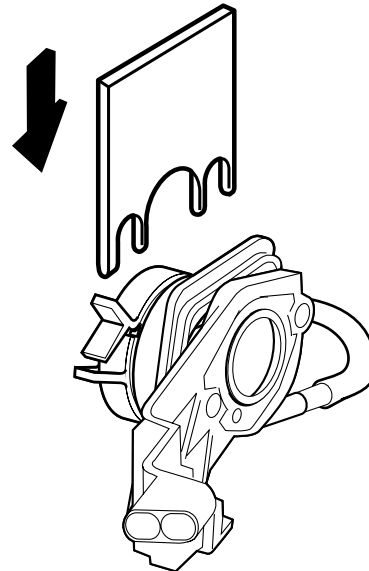

Fit stop plate 502 54 17-01 between the carburettor flange and the insulating plate.

3

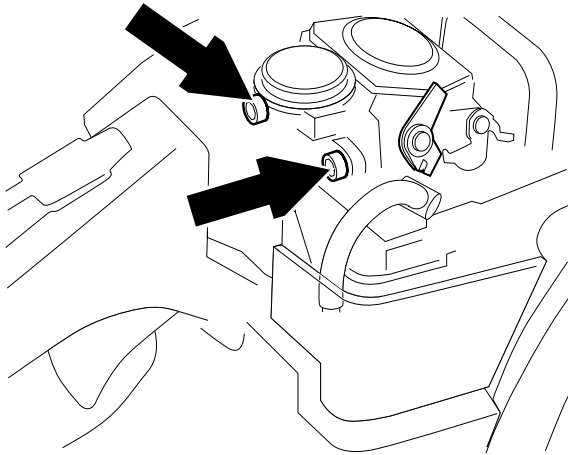

Fit the carburettor. Screw in the carburettor bolts directly from behind, without lifting the carburettor assembly. Tighten to a torque of 1–1.5 Nm. It is important to hold the carburettor flange while tightening the bolts to prevent the inlet manifold from moving.

4

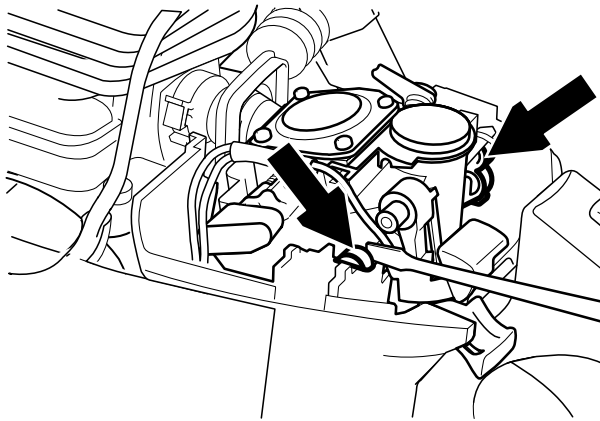

Push the rear carburettor mounting into its rubber bushing using a small screwdriver. Remove stop plate 502 54 17-01.

5

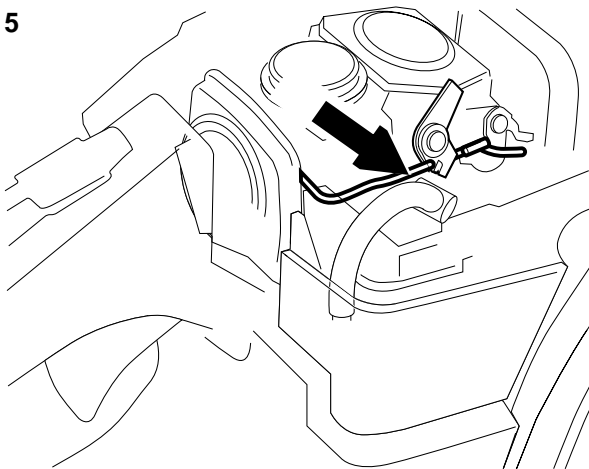

Connect the fuel hose to the carburettor. Refit the throttle pushrod at the same time as the rubber inlet manifold, press in the throttle pushrod so that it engages in the carburettor and fit the spring.

6

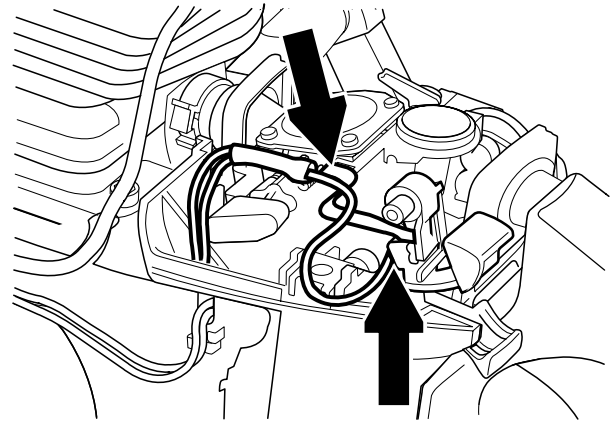

Connect the leads to the stop switch.

7

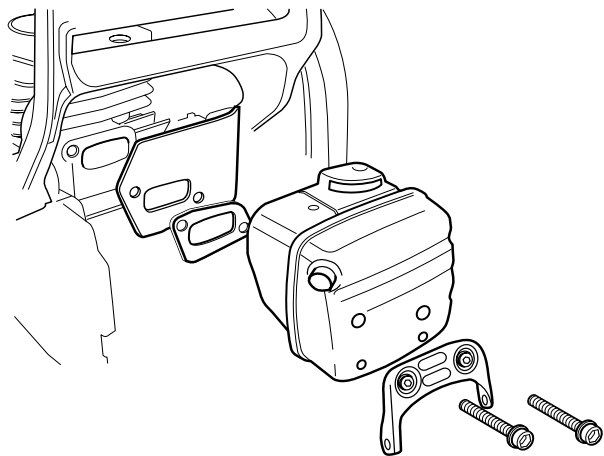

Then refit:

- cooling plate
- gasket
- silencer, tighten bolts to a torque of 12–14 Nm
- silencer support, tighten bolts to a torque of 8–10 Nm
- bark rest, tighten bolts to a torque of 8–10 Nm
- HT lead
- air filter
- cylinder cover

8

After pressure testing, re-tighten the silencer bolts to a torque of 8–10 Nm.

Air intake system – removal

The air intake system comprises:

- inlet manifold
- insulating plate with clip
- carburettor flange
- impulse hose
- support ring

1

Remove:

- cylinder cover
- air filter
- carburettor
- HT lead

2

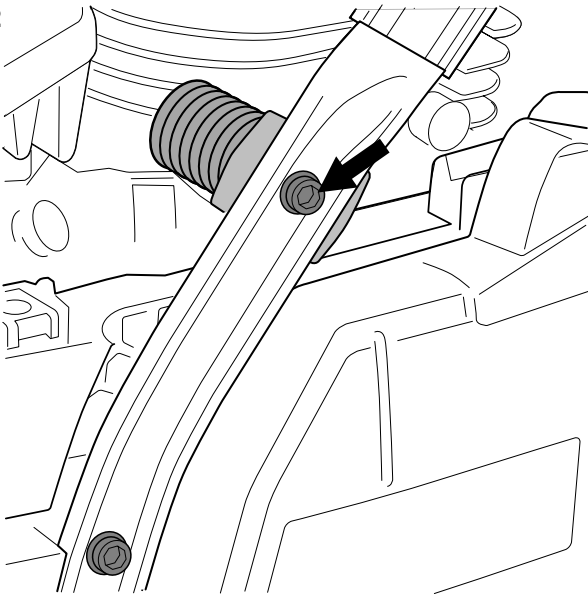

Unbolt the vibration damping spring between the cylinder and hand grip.

3

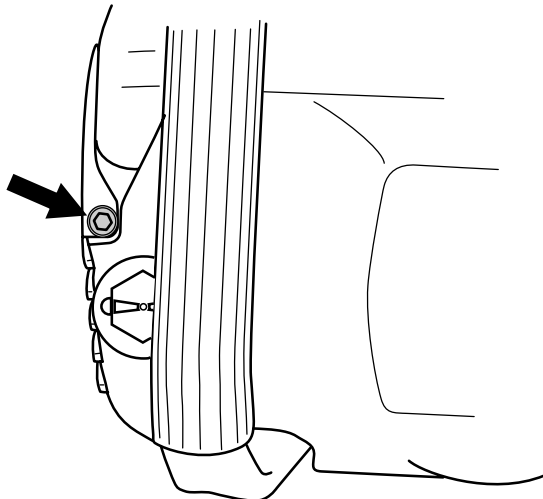

Unscrew and remove the bolts from the silencer support.

4

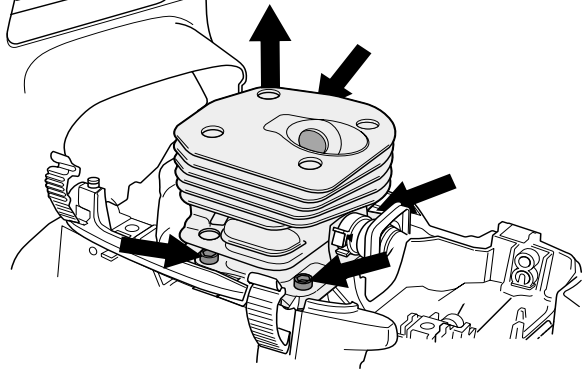

Unscrew the four cylinder bolts. Lift up the cylinder so that the intake system insulating plate is free of the crankcase.

5

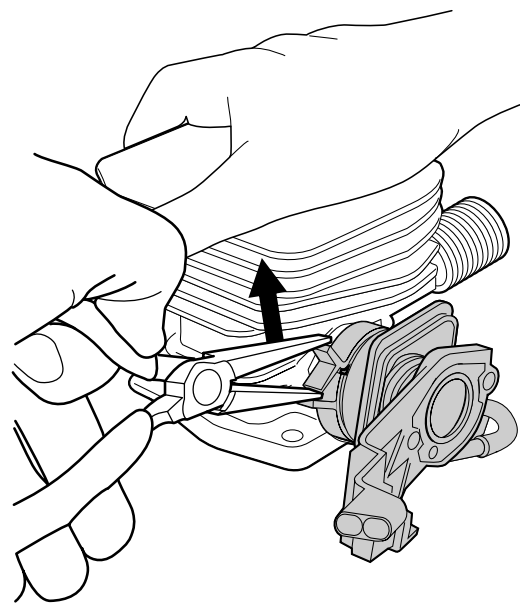

Free the insulating plate from the cylinder by releasing the clamp using pliers. Remove the complete air intake system.

6

Remove:

- support ring
- carburettor flange from the inlet manifold
- insulating plate

Cleaning and inspection

Clean and inspect all parts carefully. If there are any cracks or other defects replace the damaged parts with new ones. Always use original parts. NOTE! When replacing the impulse hose it must not be lubricated with oil or grease.

NOTE!

When you replace the impulse hose do not lubricate it with grease or oil.

Air intake system – refitting

1

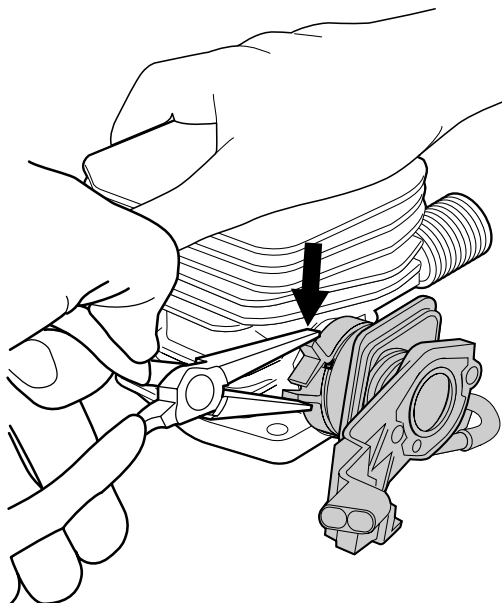

First fit the inlet manifold onto the cylinder. Then fit the insulating plate and secure it to the cylinder with the clamp. Check carefully that the impulse tube is correctly seated in the impulse channel. Fit the carburettor flange to the inlet manifold.

2

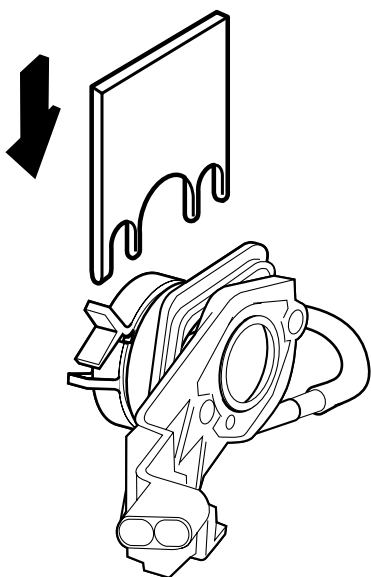

Position tool 502 54 17-01 between the carburettor flange and the insulating plate.

3

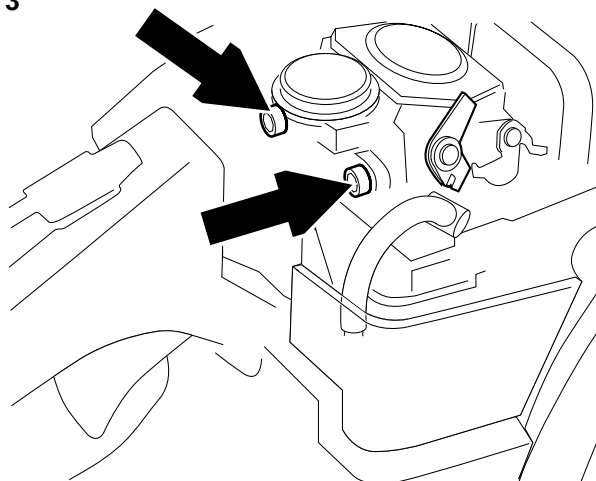

Refit the carburettor. Screw in the carburettor bolts directly from behind without lifting the carburettor assembly, tightening to a torque of 1–1.5 Nm. It is important to hold the carburettor flange securely when tightening the bolts to prevent the inlet manifold from moving.

4

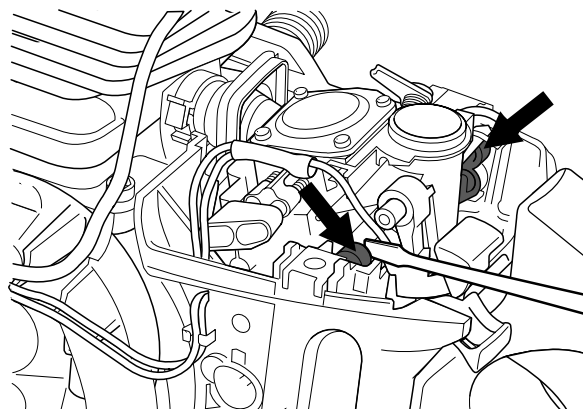

Push down the rear carburettor mounting into the rubber bushings using a small screwdriver. Remove tool 502 54 17-01.

5

Refit:

- cylinder, see "Piston and cylinder - refitting"
- silencer support, tighten bolts to a torque of 8–10 Nm
- bark rest, tighten bolts to a torque of 8–10 Nm
- air filter
- HT lead
- cylinder cover

6

After the test run retighten the silencer bolts to a torque of 8–10 Nm

Carburettor – adjustment

For instructions on adjusting the EPA carburettor see appendix A.

Adjusting the carburettor involves adjusting the engine to the local conditions e.g. climate, altitude, fuel and type of two-stroke oil.

The carburettor is equipped with three adjustment options.

- L = Low speed jet
- H = High speed jet
- T = Idling adjustment screw

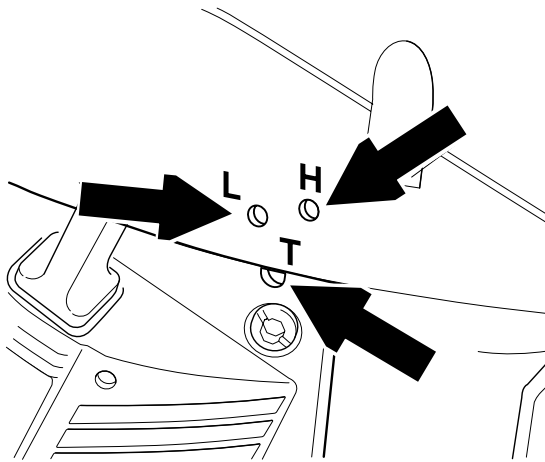

The L and H jets adjust the fuel flow to match the airflow that the throttle valve opening allows. Turning them clockwise makes the fuel/air mixture weaker (less fuel in relation to the amount of air) and turning them anti-clockwise makes the fuel/air mixture richer. A weak mixture increases the engine speed and a rich mixture decreases the engine speed.

The T screw controls the throttle position when idling. Turning the T screw clockwise gives faster idling; turning it anti-clockwise lowers idling speed.



WARNING!
The guide bar, chain and clutch cover must be fitted before the saw is started, otherwise the clutch may fly off and cause injury.

Basic settings and running in

During testing at the factory the carburettor is adjusted to the basic factory settings.

The factory settings are H = 1 turn and L = 1 turn.

To ensure that engine components receive adequate lubrication (running in) the carburettor should be set to a somewhat richer fuel mixture for the chainsaw's first 3-4 running hours. This is done by adjusting the maximum speed to 6-700 rpm less than the recommended maximum speed.

If it is not possible to check the maximum speed with a tachometer then the H jet should not be set to a weaker mixture than the basic factory setting.

The recommended maximum speed must not be exceeded.

NOTE!

If the chain turns at idling speed, the T screw should be turned anti-clockwise until the chain stops.

Fine adjustment

Once the chainsaw is "run in" the carburettor should be readjusted. First adjust the L jet screw, then the idling screw T and finally the H jet screw.

The recommended engine speeds are as follows:

Model	Max revs	Idle revs
357XP/G	14 000 rpm	2 700 rpm
359/G	13 500 rpm	2 700 rpm

Basic requirements

- Before making any adjustments the air filter should be clean and the cylinder cover should be in place. If the carburettor is adjusted with a dirty air filter, the mixture will be too weak next time the air filter is cleaned. This can cause serious engine damage.
- Carefully screw in the L and H jets fully, then back them off 1 turn. The carburettor now has the settings H = 1 and L = 1.
- Start the chainsaw and allow it to warm up for 10 minutes.
- Place the saw on a flat surface so that the guide bar is pointing away from you and the guide bar and chain are not touching the surface.

Low speed jet L

- Find the highest idling speed by slowly screwing the L screw in and then out again.
- When the highest speed has been found, screw out the L screw 1/8 - 1/4 turn.

Fine adjustment of idling speed T

- The idling speed is adjusted using the screw marked T.
- If adjustment is necessary, screw in the idling screw T until the chain starts to turn. Then screw it out until the chain stops moving.
- The idling speed is correctly set when the engine runs smoothly in all positions and there is a clear margin to the speed at which the chain starts to move.

High speed jet H

- The high speed jet H influences the saw power output and engine speed. If the H jet is set too weak the saw will over-rev, which could cause engine damage.
- Run the saw at full throttle for about 10 seconds. H=1.
- Then screw out the H screw 1/4 turn. H=1 1/4.
- Run the saw again at full throttle for about 10 seconds and listen to the difference in the engine note. Repeat this procedure again with the H screw screwed out another 1/4 turn. H=1 1/2.
- You have now run the saw at settings $H \pm 0$, $H = +1/4$ and $H = +1/2$ from the factory setting. At full throttle the engine will sound different at each setting.
- The H screw is correctly adjusted when the saw "bubbles" a little at full throttle without any load.
- If there is a lot of smoke from the silencer and the saw does not run smoothly then the setting is too rich.
- Screw in the H screw to the setting that sounds right.

NOTE!

For optimum adjustment, a tachometer should be used. The recommended maximum speed should not be exceeded.

Carburettor – correct adjustment

- When the carburettor is correctly adjusted the saw should accelerate without hesitation and the engine will burble a little at full throttle without any load.
- The chain must not turn when idling.
- If the L screw is set too weak this can make the saw difficult to start and cause poor acceleration.
- If the H screw is set too weak the saw will produce less power, poor acceleration and there is a risk of engine damage.
- If either the L or H screws are set too rich it will cause acceleration problems or too low working speed.

Fuel tank – removal



WARNING!

The fuel used in chainsaws is harmful if inhaled, may cause skin irritation and is highly flammable.

1
Empty the fuel tank.

2
Remove the following:

- cylinder cover
- air filter
- clutch cover
- chain and guide bar
- starter assembly
- cable guide

3
Disconnect the fuel hose from the carburettor.

4

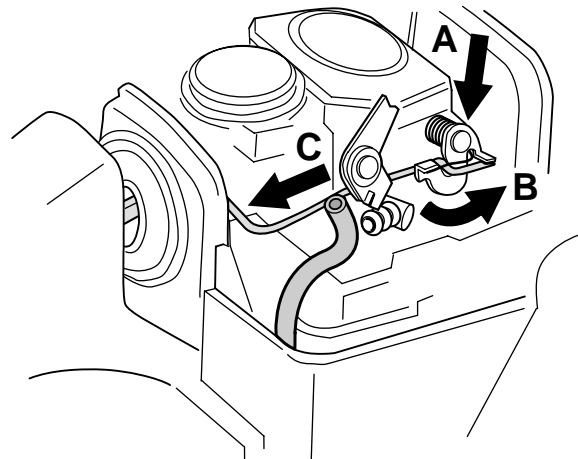

Disconnect the pushrod from the carburettor by first carefully prising up the spring over the end of the rod, where it connects to the throttle lever (A). Then press the throttle lever forwards (B) while pressing the throttle pushrod backwards (C) and lifting it off the lever. Withdraw the throttle pushrod from the tank and lift it upwards without pulling it through the rubber inlet manifold.

5

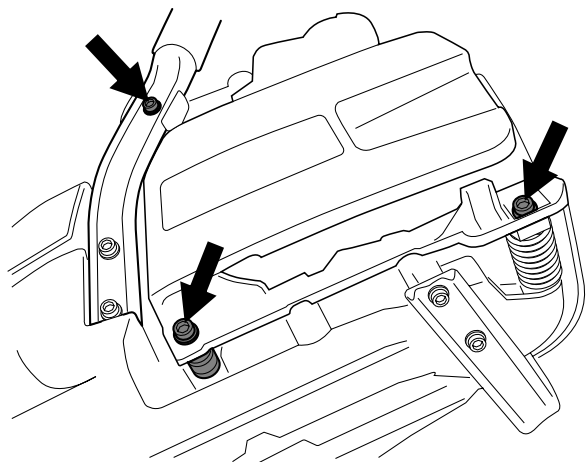
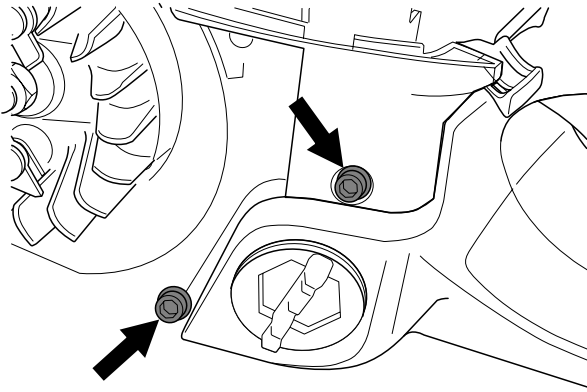

Unscrew the two stops and three vibration damping springs from the sides of the saw.

6

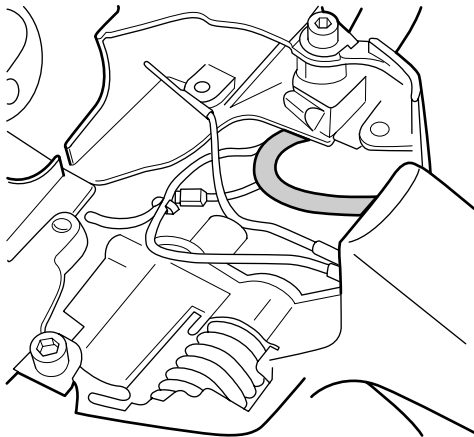

Disconnect and remove the fuel hose from the crankcase.

Cleaning and inspection

Carefully check that:

- there are no leaks from the fuel tank
- there are no leaks from the tank filler cap
- the fuel hose is undamaged and free from wear
- the fuel filter is not clogged
- the tank vent is not blocked or leaking
- the vibration damping springs and stops are not damaged

Replacing the fuel filter

NOTE!

Do not use knurled pliers to disconnect or reconnect the fuel hose. This could damage the hose and lead to leakage or fracture.

1

First remove the old fuel filter from the tank unit using special tool 502 50 83-01.

2

Pull the fuel hose out of the tank and pull off the filter.

3

Fit the new fuel filter and feed the fuel hose back into position.

Replacing the fuel hose

NOTE!

Do not use knurled pliers to disconnect or reconnect the fuel hose. This could damage the hose.

1

Before replacing the fuel hose, measure the length of hose between the crankcase and carburettor and between the tank and crankcase. The correct hose length between the tank and crankcase is 43 mm (1.69 inches). The correct hose length between the crankcase and carburettor is 53 mm (2.09 inches).

2

Remove the fuel hose from the fuel tank using tool 502 50 83-01. Trim off 5 mm (0.20 inches) from the mitred end of the hose. Fit the fuel filter and reinsert the hose in the tank.

Tank vent – testing

1

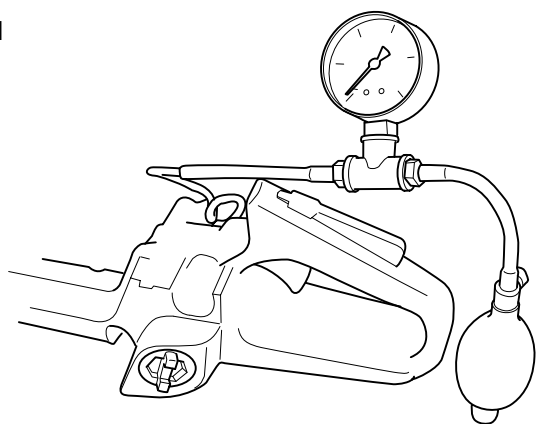

Connect pressure gauge 502 50 38-01 to the fuel hose. Pump the pressure up to 50 kPa (0.5 bar). The pressure should drop to 20 kPa (0.2 bar) within 60 seconds.

2

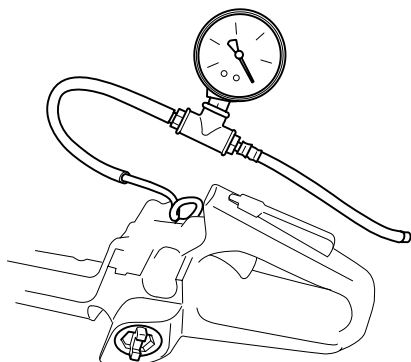

Use gauge 502 50 37-01 to measure vacuum. Readings should be as follows: the vacuum should increase from 30 to 15 within 30 seconds. If readings are outside this range the vyon plugs must be replaced.

Fuel tank – refitting

1

Insert the fuel hose into the carburettor chamber. Refit the fuel tank.

2

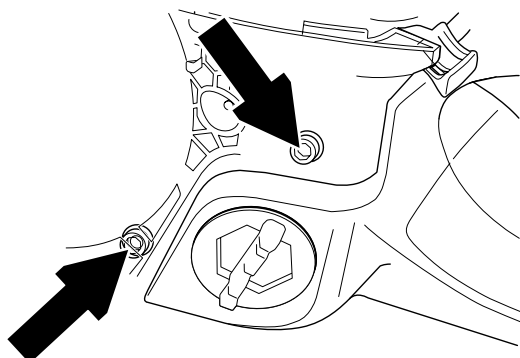

Bolt the front vibration damping spring into position, followed by both stops and the remaining two vibration damping springs. Tighten to a torque of 2–3 Nm. Check that both vibration damping springs and the stops are correctly seated on the crankcase. Incorrect fitting may result in higher vibration levels.

3

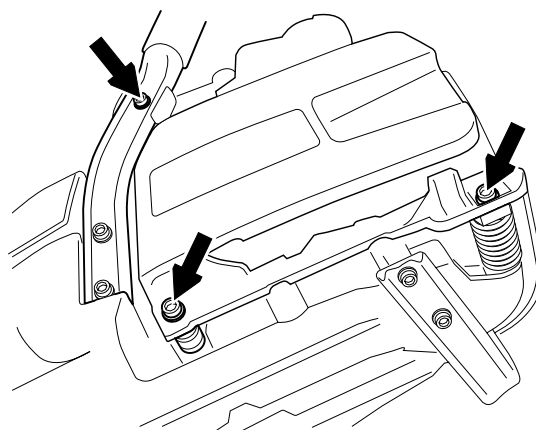

Fit the throttle pushrod in the tank and connect it to the carburettor. Refit the spring.

4

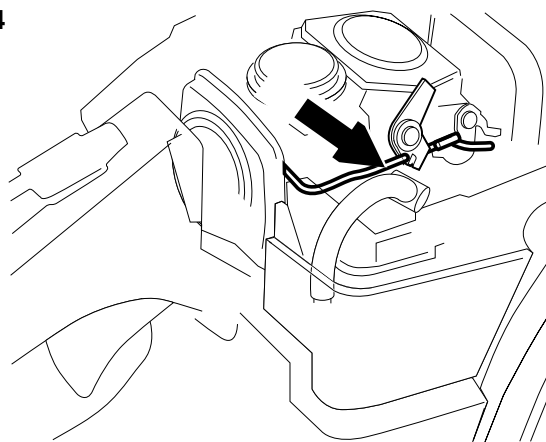

Connect the fuel hose to the carburettor. Check that the hose is not twisted and is not too long so that it gets trapped between the crankcase and tank. The correct hose length between the tank and crankcase is 43 mm (1.69 inches). The correct hose length between the crankcase and carburettor is 53 mm (2.09 inches) excluding the mitred section.

5

Connect the fuel hose to the carburettor.

6

Then refit:

- cable guide
- starter assembly (2.5–3 Nm)
- chain and guide bar
- clutch cover
- air filter
- cylinder cover

Piston and cylinder – removal

1

Remove:

- cylinder cover
- carburettor, see "Carburettor - removal"
- silencer
- spark plug.

2

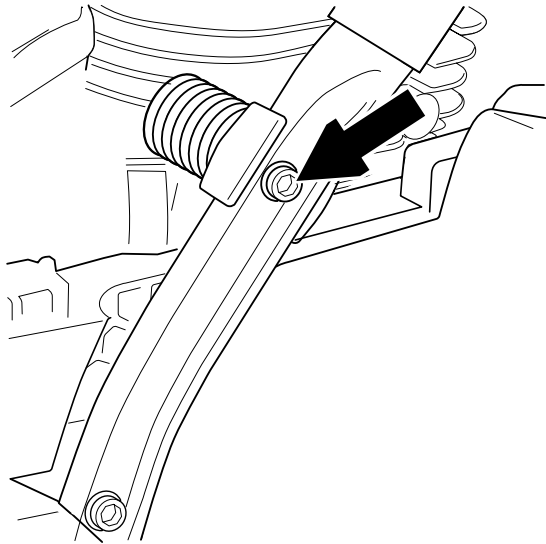

Unbolt the vibration damping spring from the hand grip.

3

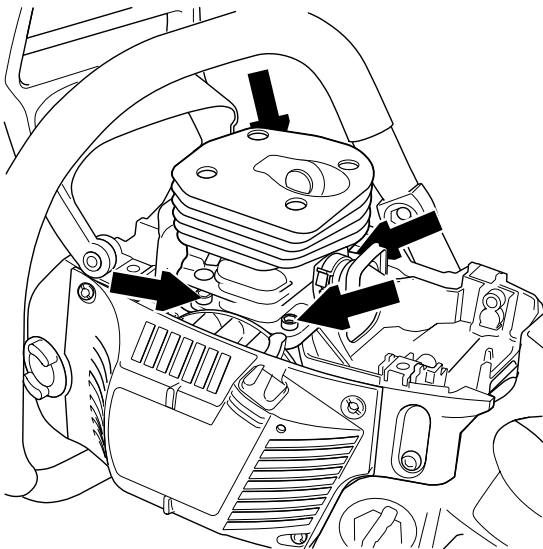

Undo the four cylinder bolts and lift the cylinder off carefully.

4

Cover the opening in the crankcase.

5

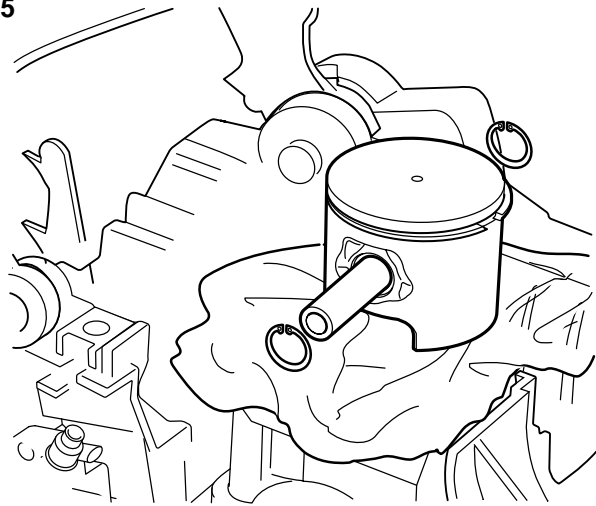

Remove the circlips from the ends of the gudgeon pin and press it out. Then lift off the piston.

6

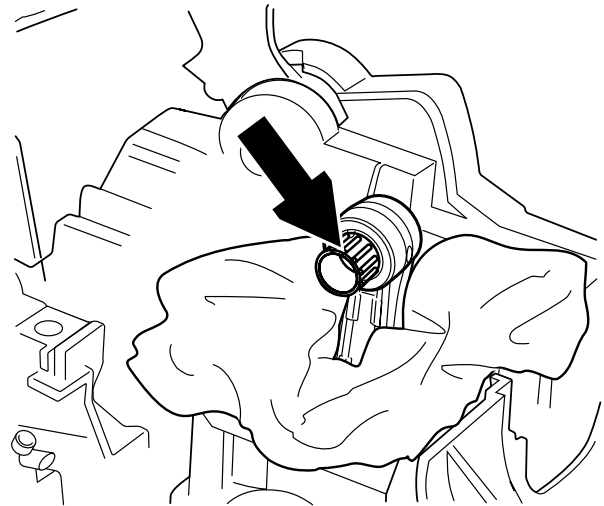

Remove the bearing from the little end of the connecting rod.

7

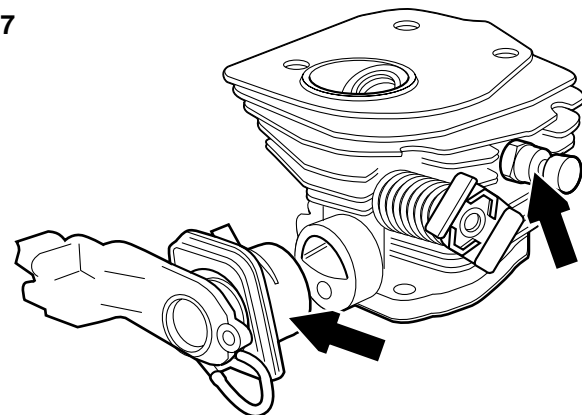

If replacing the cylinder:
Unscrew the decompression valve. Remove the air intake system, see "Air intake system - removal".

Cleaning and inspection

Clean all the components, scraping off all traces of old gasket and carbon from the following places:

- Piston crown
- Top of the cylinder bore
- Cylinder exhaust port
- Decompression valve channel
- Cylinder base and/or crankcase

Check the following:

- The surface coating of the cylinder is not worn through, especially in the upper part of the cylinder.
- The cylinder is free from score marks and areas of wear.
- The piston is free from score marks. Small scratches can be polished out with fine emery paper.
- The piston ring is not burnt into its groove.

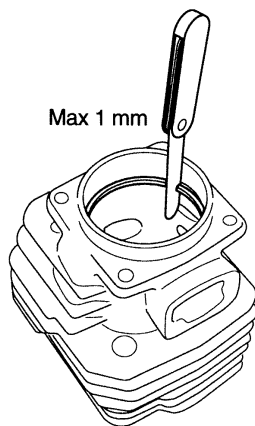

- Measure piston ring wear. This should not exceed 1 mm. Use the piston to push down the piston ring.
- The needle roller bearing is undamaged.
- The inlet manifold is undamaged.
- Pressure test the decompression valve.
- Also refer to Jonsered's Analysis guide for piston failures, art. no. 108 07 01-01.

Decompression valve – pressure testing

1

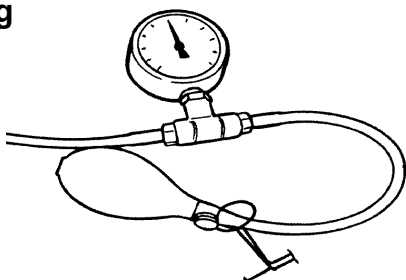

Connect tool 502 50 38-01 to the decompression valve.

2

Pump up the pressure to 80 kPa (0.8 bar).

3

Wait 30 seconds.

4

The pressure should not be less than 60 kPa (0.6 bar).

Piston and cylinder – refitting

1

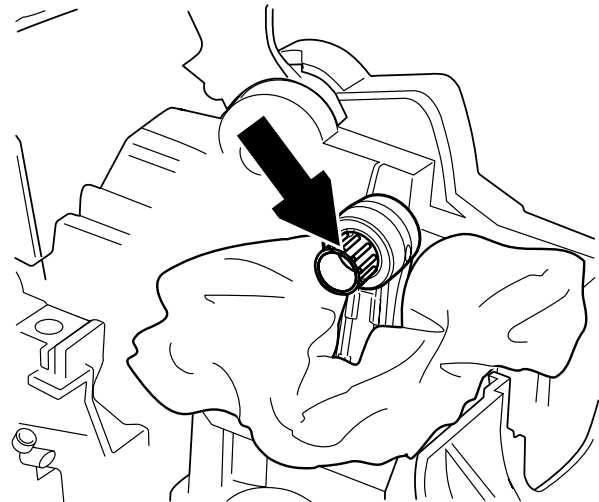

Lubricate the little end bearing with two-stroke oil and insert it in the connecting rod.

2

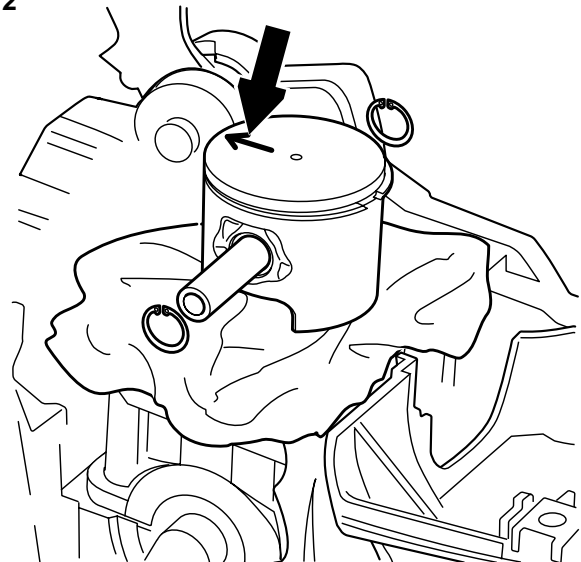

Fit the piston with the arrow pointing towards the exhaust port. Push in the gudgeon pin and fit the circlips. If replacing the cylinder, fit the decompression valve, tightening to a torque of 12–14 Nm.

3

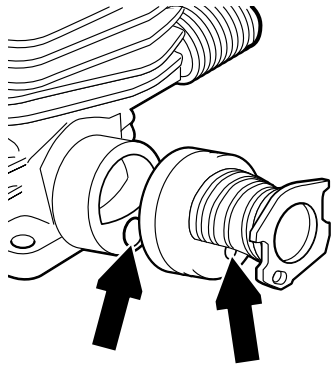

Fit the inlet manifold 503 86 63-01 to the cylinder. Check that the impulse tube is correctly seated in the impulse channel.

NOTE!

It is very important that there are no leaks in the inlet system, otherwise the engine may seize.

4

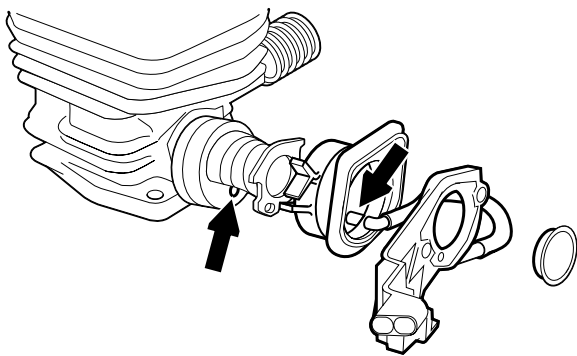

Press the insulating plate 503 86 62-01 onto the cylinder. Check that the impulse tube connected to the insulating plate is seated correctly in the inlet manifold and lock the clamp over the manifold.

5

Lubricate the piston ring and piston with two-stroke oil.

6

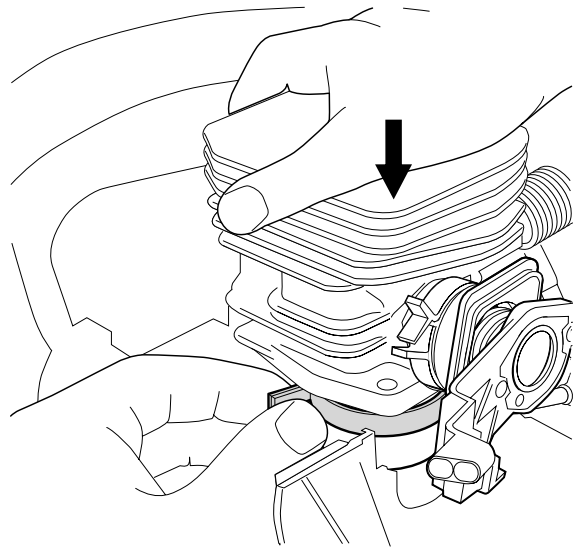

Fit a new cylinder base gasket. Compress the piston ring with tool 502 50 70-01 and lower the cylinder over it carefully.

7

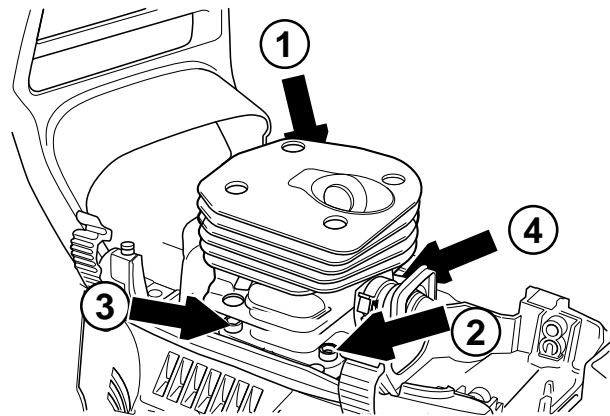

Fit the cylinder bolts, tightening them in diagonal pairs to a torque of 8–10 Nm.

8

Pressure test the cylinder.

9

Refit:

- spark plug, tighten to a torque of 15 Nm
- carburettor, see "Carburettor - refitting".
- silencer, tighten to a torque of 8–10 Nm
- cylinder cover

NOTE!

If a new piston or cylinder has been fitted the saw must be run for the first 3–4 hours with carburettor adjusted to the factory settings.

Cylinder – pressure testing

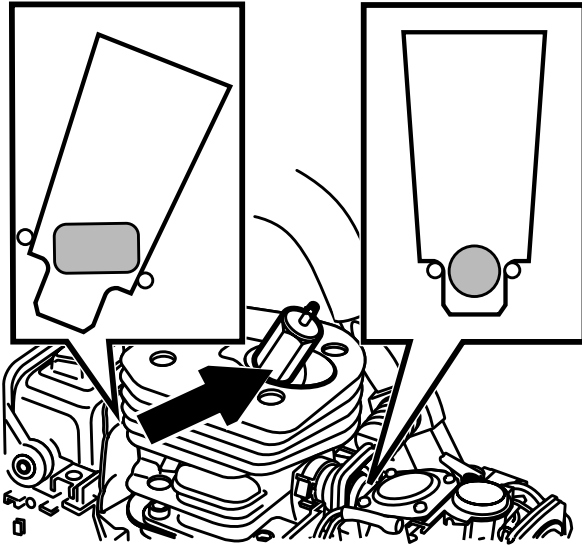

- Loosen the carburettor bolts so that the carburettor can be moved back about 4 mm. Insert cover plate 502 54 11-02 between the carburettor and the carburettor flange. Tighten the carburettor bolts to a torque of 1–1.5 Nm.
- Loosen the silencer bolts so that the silencer can be moved back about 4 mm. Insert cover plate 502 54 11-02 between the silencer and the exhaust flange on the cylinder flange. Tighten the silencer bolts to a torque of 8–10 Nm.
- Unscrew and remove the spark plug. Screw in pressure test nipple 503 84 40-02. Connect tool 502 50 38-01 to the nipple. The decompression valve must be closed. For instructions on testing the decompression valve see "Decompression valve - pressure testing".
- Pump up the pressure to 80 kPa (0.8 bar).
- Wait 30 seconds.
- The pressure should not be less than 60 kPa (0.6 bar).
- Remove the cover plates from the silencer and carburettor, tighten the bolts to the specified torque. Remove the pressure test nipple 503 84 40-02 and refit the spark plug.



WARNING!
After pressure testing the cylinder, check that the inlet manifold is seated correctly, otherwise the saw may be damaged.

Crankcase and crankshaft – dismantling

1

Remove the following:

- guide bar and chain
- clutch cover
- cylinder cover
- starter assembly, see "Starter assembly - removal"
- ignition system, see "Ignition module/flywheel - removal"
- generator, see "Replacing the generator"
- centrifugal clutch, see "Centrifugal clutch - removal"
- oil pump, see "Oil pump - removal"
- bark rest
- chain tensioner
- throttle pushrod
- carburettor, see "Carburettor - removal"
- carburettor base
- silencer, see "Silencer - removal"
- piston and cylinder, see "Piston and cylinder - removal"
- fuel tank, see "Fuel tank - removal"

NOTE!

Take care to prevent dirt or foreign particles getting into the bearings.

2

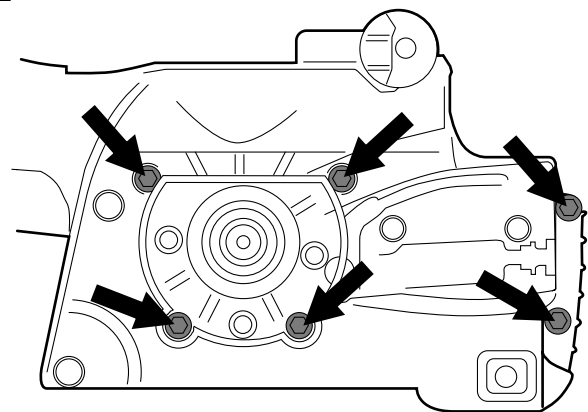

Unscrew the 6 bolts that hold the crankcase together.

3



WARNING!
Take care not to burn yourself when the crankcase is hot. Wear protective gloves.

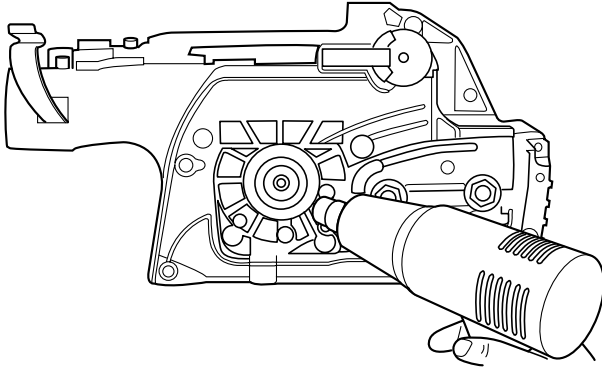

Split the crankcase by heating the flywheel side of the crankcase with a hot air gun and tapping gently on the crankshaft. Avoid heating the frame bearing and crankshaft.

4

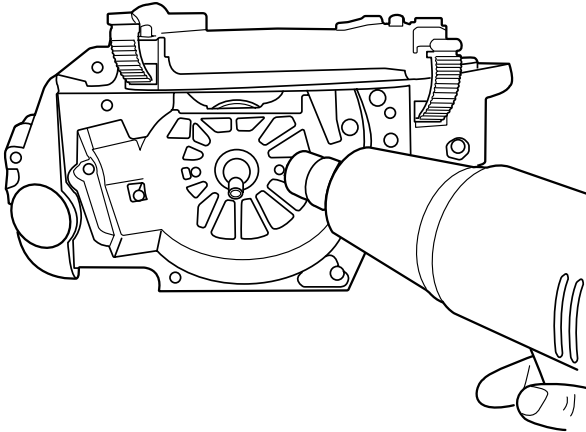

Free the crankshaft by heating the clutch side of the crankcase.

Crankshaft bearings – replacement

If the crankshaft bearings are to be replaced they must be pulled off the crankshaft using puller 504 90 90-02. The new bearings must be shrunk-fit into the crankcase using a hot air gun. Heat the crankcase half to around 130°C and fit the new bearing.

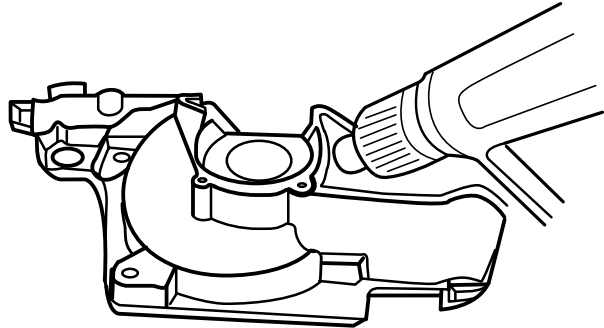

The new bearings must be shrunk-fit into the crankcase using a hot air gun.

Cleaning and inspection

Clean and inspect all parts carefully.

Sealing ring – replacement

Remove the sealing ring from the crankcase using a small screwdriver.

NOTE!

Take care to avoid damaging the crankcase.

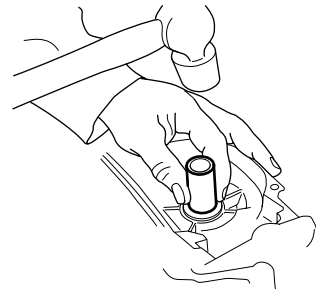

To fit the sealing ring use the sleeve that is supplied with 502 50 30-16.

The end with the half moon is used for the sealing ring on the clutch side, which must be fitted flush with the surface of the crankcase.

The other end of the sleeve is used to fit the sealing ring on the flywheel side and ensures that the sleeve is fitted at the correct depth, 1.8 mm. Lubricate the sealing rings with oil.

Crankcase and crankshaft – reassembly

1

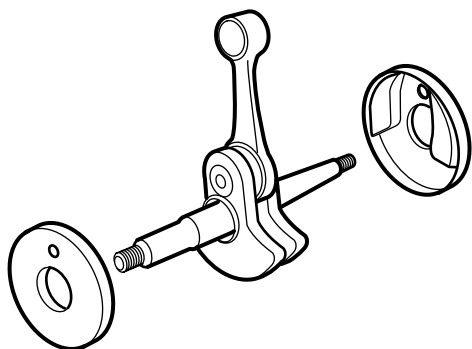

357 only:

Fit the cups on the crankshaft.

NOTE!

It is important that the cups are fitted over the counterweights.

2

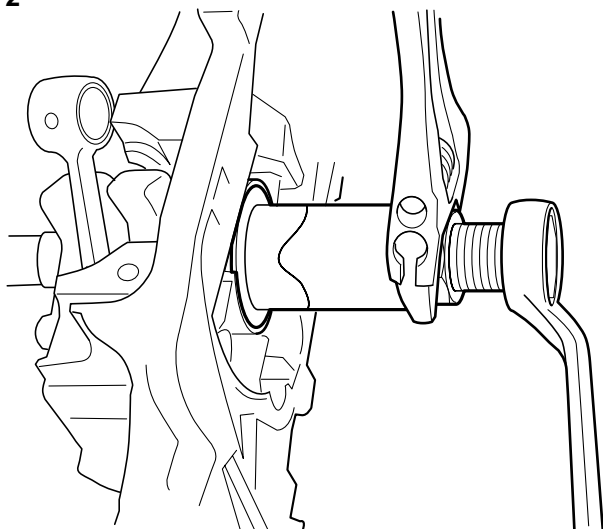

Hold the clutch side of the crankcase in a vice. Pull the crankshaft into its bearing using assembly tools 502 50 30-16.

3

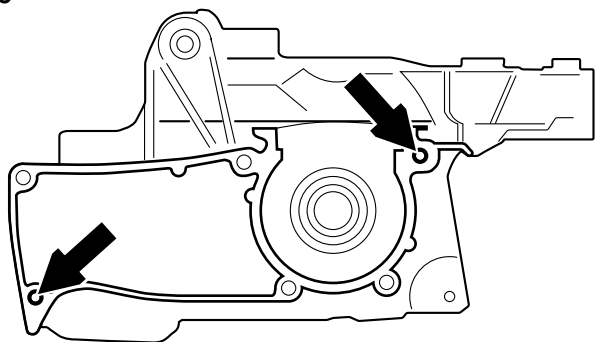

Check that the guide pins are in place. Fit a new gasket to the mating surface of the clutch side of the crankcase.

4

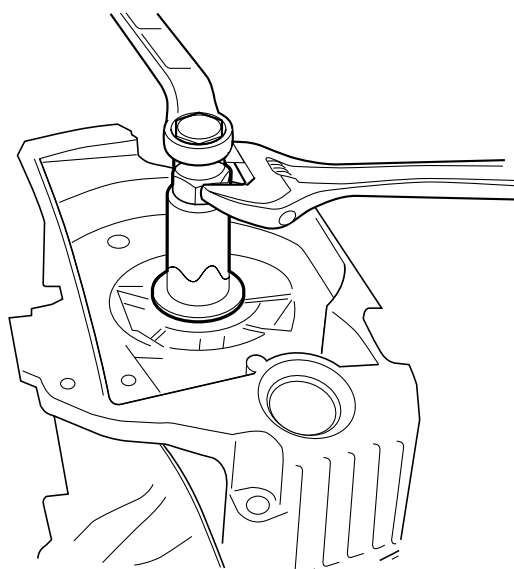

Place the flywheel side of the crankcase over the crankshaft and pull the two crankcase halves together using assembly tools 502 70 84-01 and 502 50 30-16.

5

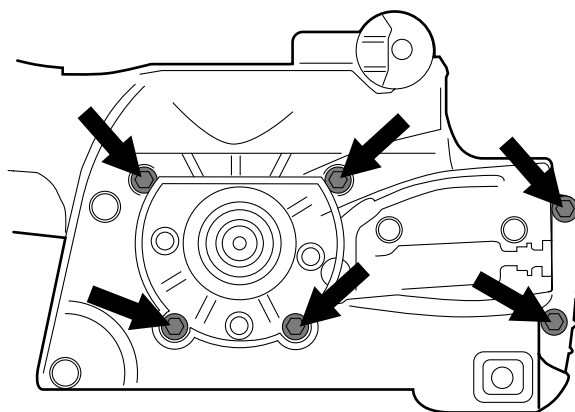

Fit and tighten the six crankcase bolts to a torque of 8–10 Nm. Check that the crankshaft rotates freely.

Refit the following parts:

- bark rest, 8-10 Nm
- oil pump, 3-4 Nm, see "Oil pump - refitting"
- chain tensioner
- centrifugal clutch, min 20 Nm, see "Centrifugal clutch - refitting"
- fuel tank, see "Fuel tank - refitting"
- piston and cylinder, see "Piston and cylinder - refitting"
- generator, see "Replacing the generator"
- carburettor base, 3-4 Nm
- carburettor, 1-1,5 Nm, see "Carburettor - refitting"
- throttle pushrod
- silencer, 12-14 Nm, see "Silencer - refitting"
- ignition system, 8-10 Nm, see "Ignition module and flywheel - refitting"
- starter assembly, 2,5-3,5 Nm, see "Starter assembly - refitting"
- cylinder cover
- clutch cover
- guide bar and chain

NOTE!

If a new crankshaft has been fitted the saw must be run in for 3-4 hours with the carburettor adjusted to the factory settings.

Repairing damaged threads

A repair kit, 503 27 33-01, is available for repairing damaged threads.

First drill out the hole using:

6.1 mm drill bit for magnesium crankcase

Then screw in the thread insert using a suitable bolt and spanner.

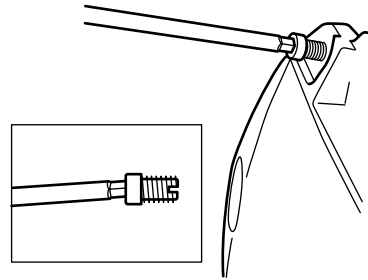

Guide bar bolts – replacement

1

Drain the oil tank.

2

Knock through the old guide bar bolt so that it falls into the oil tank.

3

Remove the bolt from the oil tank.

4

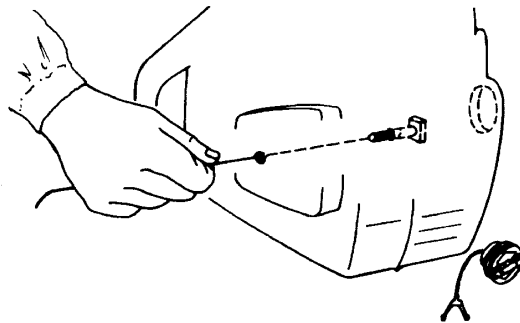

Fasten a steel wire to the thread of the new bolt, feed the steel wire into the oil tank and out through the bolt hole in the crankcase.

5

Pull the steel wire until the bolt comes out through its hole.

6

Pull through the bolt with its nut. Place a spacer between the nut and crankcase.

7

Check that the square shoulder of the bolt is correctly seated in the recess in the crankcase.

8

Refill with chain oil.

Appendix A

Carburettor – EPA models

Basic adjustment for EPA carburettors

After replacing the carburettor or high speed and/or low speed needle on an EPA (The US Environmental Protection Agency) certified product a basic adjustment must be carried out as described below in order to meet the EPA-requirements. This to achieve as low emissions as possible. This instruction is made for USA only.

On EPA carburettors both the H and L-needles are fitted with caps to prevent the chain saw operator from changing the adjustment above EPA standard. The caps can be removed to achieve richer or leaner adjustments. To set the needles correctly an *adjustment sleeve* is fitted over the caps to lock them in maximum allowed setting. When correctly set the caps must be fixed on the needles. The adjustment sleeve then can be removed.

NOTE! Before making any adjustments the following must be done.

- Mount, for this model, approved bar & chain combination for a 16" bar (see Technical data in the Operator's manual).
- The chain should not be tensioned more than that it remains ~0.2 inches to the bar.
- Mount a **new** air filter.

Replacement of the H-needle or complete carburettor

1. Screw the new H-needle to the bottom and turn it counterclockwise "3/4" turns.

2. Check that:

- The H-cap is adjusted to its richest setting. (Turned counterclockwise to stop.)
- The cap is not fixed to the needle, it should rotate independently. Adjust the L-cap to a center position (1/4 turn counterclockwise = minimum, 1/4 turn clockwise = maximum).

3. Start the engine. If necessary, adjust the idling speed with the T-screw until the chain stops.

4. Adjust the H-needle to give a top speed of "A" rpm.

Model 357XP A= 13 500

Model 359 A= 12 500

Use a narrow blade screwdriver (Ref.no. 531 00 48-63) and insert it through the hole in the cap. (max. blade width 2 mm/0.08 inch).

5. Let the engine run at 13 000 rpm ~1 minute, until warm.

6. Adjust the H-needle to a top speed of "B" rpm.

Model 357XP B= 14 500

Model 359 B= 13 000

7. Check that the H-cap is still adjusted to its richest setting. (Turned counterclockwise to stop). **NOTE! The H-needle must not rotate!**

8. Gently knock the H-cap into position. Use a 5 mm/0.2 inch mandrel (for ex. the locking pin for the bevel gear ref.no. 502 02 61-03).

This is a basic carburettor adjustment. Further fine adjustments, within the limits the caps allow, may be necessary to achieve optimum performance. See the Operator's manual.

Replacement of the L-needle

1. Take off the cap from the L-needle e.g. a pair of cutting pliers and unscrew the needle.

2. Screw the new L-needle to the bottom and then turn it counterclockwise 1 1/2 turns.

3. Press a new L-cap on the L-needle to the first stop, which means that the cap is not fixed to the needle, it should rotate independently.

4. Adjust the L-cap to the richest position (turned counterclockwise to stop) without turning the needle.

5. Let the engine run at ~"C" rpm app. 1 minute until warm and then let it run on idle.

Model 357XP C= 13 500

Model 359 C= 12 500

6. Adjust the idle speed to 2 700 rpm.

7. Adjust the L-needle until the highest possible idling speed is achieved and then run the L-needle 1/2 turn counterclockwise. Use a narrow blade screw-driver w. ref.no. 531 00 48-63 and insert through the hole in the cap (max. blade width 2 mm/0.08 inch).

NOTE! If the chain rotates, turn the idling speed screw (T) counterclockwise until the chain stops.

8. Check that the L-cap is still adjusted to its richest position. (Turned counterclockwise to stop). **NOTE! The L-needle must not rotate!**

9. Gently knock the L-cap into position. Use a 5 mm/0.2 inch mandrel (for ex. the locking pin for the bevel gear ref.no. 502 02 61-03).

This is a basic carburettor adjustment. Further fine adjustments, within the limits the caps allow, may be necessary to achieve optimum performance. See the Operator's manual.