Workshop manual

Husqvarna 435 II, 435e II, 440 II, 440e II and 440e II TrioBrake

Contents

Index	4
Introduction and safety instructions	6
Technical data	10
Service tools	12
Service data	14
Safety equipment	16
Repair instructions	24
Carburettor	33
Troubleshooting	53

Husqvarna AB has a policy of continuous product development and therefore reserves the right to modify the design and appearance of products without prior notice.

Index

B

Bar bolt 52

Replacing the bar bolt 52

C

Carburettor 33

Assemble on the saw 40
 Assembly 38
 Carburettor adjustment 41
 Cleaning and inspection 37
 Design 33
 Dismantling 35
 Function 34
 Pressure testing the carburettor 39

Centrifugal clutch 30

Centrifugal clutch - refitting 31
 Centrifugal clutch - removal 30
 Inspection and cleaning 30

Chain brake 17

Chaine brake - reassembly 18
 Cleaning and inspection 17
 Dismantling the chaine brake 17

Chain catcher 20

Chain catcher - replacement 20

Crankcase and crankshaft 50

Crankshaft bearings - replacement 50
 Crankshaft complete - dismantling 50
 Crankshaft complete - reassembly 51

F

Fuel system 44

Replacing the fuel filter 44
 Replacing the fuel hose/return hose 44
 Replacing the air-purge 44
 Venting the fuel tank 42

I

Ignition module and flywheel 28

Cleaning and inspection 28
 Ignition module - testing 27
 Ignition module and flywheel - refitting 29
 Ignition module and flywheel - removal 28

Intake system 32

Air intake system removal 32
 Assembling the intake system 32, 48
 Cleaning and inspection 32

Introduction and safety instructions 7

Changes 7
 General 7
 General Instructions 8
 Numbering 7
 Safety 7
 Special Instructions 8

Symbols in the Workshop Manual 9

Symbols on the saw 9

Structure 7

Target group 7

Tools 7

O

Oil pump and screen 31

Assembling the oil pump and screen 32
 Cleaning and inspection 31
 Dismantling the oil pump and screen 31

P

Piston and cylinder 45

Cleaning and inspection 45
 Cylinder - pressure testing 49
 Faults and causes 47
 Piston and cylinder - refitting 47
 Piston and cylinder - removal 45

S

Service data 14

Special tools 12

Silencer 19

Cleaning and inspection 19
 Silencer - refitting 19
 Silencer - removal 19

Starter 25, 26

Changing a broken or worn starter cord 26
 Cleaning and inspection 25, 26
 Replacing a worn recoil spring 27
 Starter assembly - refitting 27
 Starter assembly - removal 25
 Tensioning the recoil spring 26

Start/Stop switch 20

Assembling the start/stop control 21
 Cleaning and inspection 20
 Dismantling the start/stop control 20

Stopping function 21

Stop switch - resistance measurement 21

T

Tank unit 42

Assembly 43
 Dismantling 42

Technical Data 10

Threads 51

Repairing damaged threads 51

Throttle lock, throttle trigger and return spring 22

Cleaning and inspection 23
 Throttle lock, throttle trigger and return spring - refitting 23
 Throttle lock, throttle trigger and return spring - removal 22

Trouble shooting 54

Trouble-shooting methods 55

V**Vibration damping system 43**

Assembly 43

Cleaning and inspection 43

Dismantling 43

2 Introduction and safety instructions

Contents

2.1	General	7
2.2	Safety	7
2.3	Target group	7
2.4	Changes	7
2.5	Tools	7
2.6	Structure	7
2.7	Numbering	7
2.8	General instructions	8
2.9	Special instructions	8
2.10	Symbols on the saw	9
2.11	Symbols in the Workshop Manual	9

2 Introduction and safety instructions

2.1 General

This Workshop Manual describes in detail how the chain saw is to be fault traced, repaired and tested. A description of different safety measures that should be taken during repair work is also given.

2.2 Safety

Note! The section dealing with safety must be read and understood by all those carrying out repair work or service on the chain saw.

Warning symbols can be found in this Workshop Manual and on the chain saw. See "Symbols on the saw" and "Symbols in the Workshop Manual". A new decal must be applied as soon as possible if a warning symbol on the chain saw has been damaged or is missing so that the greatest possible safety can be obtained when using the chain saw.

2.3 Target group

This Workshop Manual is written for personnel with general knowledge about the repair and service of chain saws.

The Workshop Manual must be read and understood by personnel who will carry out repair work and service on the chain saw. The Manual is also suitable for use when training new employees.

2.4 Changes

Modifications will be successively introduced on the chain saw during production. When these modifications affect the service and/or spare parts, separate service information will be sent out on each occasion. This means that in time this Workshop Manual will become out of date. In order to prevent this, the Manual should be read together with all service information concerning the chain saw in question.

2.5 Tools

Special tools are required for some stages. All service tools are listed in the Workshop Manual. Usage is evident from respective sections.

Always use Husqvarna's original:

- Spare parts
- Service tools
- Accessories

2.6 Structure

This Workshop Manual can be used in two different ways:

- For the repair of a particular system on the chain saw.
- Dismantling and assembly of the entire chain saw.

Repair of a specific system

When a particular system on the chain saw is to be repaired, proceed as follows:

1. Look up the page for the system in question.
2. Carry out the sections: Dismantling
Cleaning and inspection
Assembling

Dismantling and assembling the entire chain saw

Proceed as follows when the entire chain saw is to be dismantled and assembled:

1. Look up the chapter "Repair instructions", which deals with the **Starter** and carry out the instructions set out under **Dismantling**.
2. Work forward in the Manual and carry out **Dismantling** in the order set out in the sections.
3. Go back to the **Starter** and carry out the instructions under **Cleaning and Inspection**.
4. Work forward in the Manual and carry out **Cleaning and Inspection** in the order set out in the sections.
5. Order or take out all requisite spare parts from the stores.
6. Look up the chapter "Repair instructions" which deals with the **Crankcase** and carry out the instructions set out under **Assembling**.
7. Work back in the Manual and carry out **Assembling** in the order set out in the sections.

Some sections include a **Description** of the actual unit in order to increase the basic understanding.

2.7 Numbering

Position references to components inside the figures are designated A, B, etc. The figures are numbered 1, 2 etc. The position references and figure numbers restart in each new section.

2.8 General instructions

The workshop where chain saw repairs are to be done must be equipped with safety equipment as set out in local provisions.

No one may repair the chain saw unless they have read and understood the content of this Workshop Manual.

In this workshop manual the following boxes indicate where caution should be taken.



WARNING!
The warning text warns of the risk of personal injury if the instructions are not followed.

NOTE!

The warning text warns of the risk of material damage if the instructions are not followed.

2.9 Special instructions

The fuel that is used in a chainsaw poses the following hazards:

- The fuel and its fumes are toxic.
- May cause irritation to skin or eyes.
- May cause breathing difficulties.
- Highly flammable.

When using compressed air the air jet should never be pointed at the body. Air can be forced into the bloodstream and cause fatal injury.

Wear ear protection when testing saws.

After testing a saw do not touch the silencer until it has cooled down. The silencer gets very hot and you may burn yourself. Wear protective gloves when working on the silencer.

The guide bar, chain and clutch cover (chain brake) must be fitted before the saw is started. If not, the clutch may come loose and cause injury.

Poor chain lubrication can result in failure of the chain, which could cause serious or fatal injury.

Take care to ensure that the spring inside the starter assembly does not fly out and cause injury. Wear eye protection. If the spring is under compression when the pulley is removed it could fly out and cause injury.

Before removing the tensioning spring from the chain brake, ensure that the brake is in the on position, otherwise the spring may fly out and cause injury.

After completing the repair the chain brake must be tested, see "Chain brake – reassembly \ Operating test".

Always consider the fire risk. A chainsaw can produce sparks that could start a fire.

Inspect the chain catcher and replace it if it is damaged.

2.10 Symbols on the saw

The symbols below are embedded on the chain saw.



Choke Lever

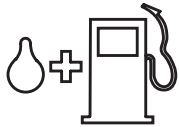

Refuelling



Stop button



Chain oil fill.



Chain brake

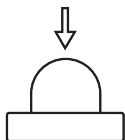

Fuel pump

2.11 Symbols in the Workshop Manual



This symbol warns of personal injury when the instructions are not followed



Use protective gloves.



Use protective goggles.

3 Technical data



Displacement
cm³/cubic inches

435/e II: 40,9 / 2,49
440/e II/TB: 40,9 / 2,49

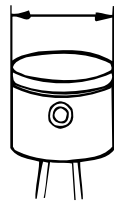

Cylinder bore
Ø mm/Ø inches

41 / 1,51
41 / 1,51

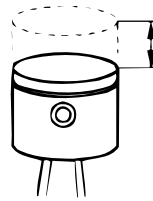

Stroke
mm/inches

31 / 1,22
31 / 1,22

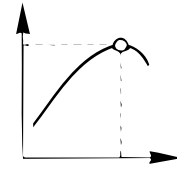

Max power/speed
kW/hp/rpm

1,6 / 2,1 / 9 000
1,8 / 2,4 / 9 000

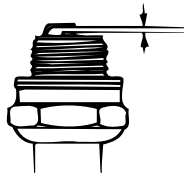

Spark plug gap
mm/inches

435/e II: 0,5 / 0,02
440/e II/TB: 0,5 / 0,02

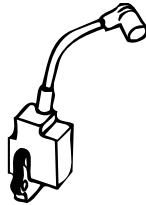

Ignition system

Walbro MBU-52
Walbro MBU-52

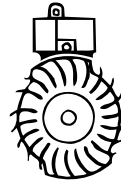

Air gap
mm/inches

0,3 / 0,012
0,3 / 0,012

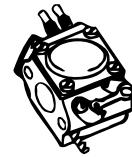

Carburettor type

Zama C1T-EL41A
Zama C1T-EL41A

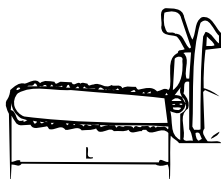

Effective cutting length
cm/inches

435/e II: 33-46 / 13-18
440/e II/TB: 33-46 / 13-18



Maximum
chain speed
m/s

23,1
23,1

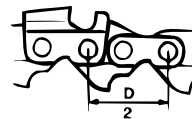

Chain pitch
mm/inches

8,25 / 0,325
8,25 / 0,325

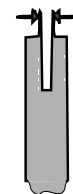

Drive link
mm/inches

1,3 / 0,050 - 1,5 / 0,058
1,3 / 0,050 - 1,5 / 0,058

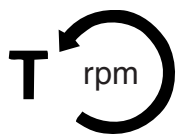

Idling speed
rpm

435/e II: 2 900

440/e II/TB: 2 900

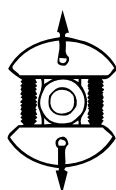

Engagement speed
rpm

4 300

4 300



Spark plug

NGK BPMR 7A
Champion RCJ 7Y
NGK BPMR 7A
Champion RCJ 7Y

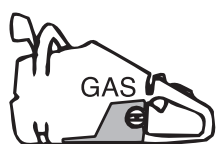

Fuel tank capacity
Litres/US pints

435/e II: 0,37 / 0,78

440/e II/TB: 0,37 / 0,78

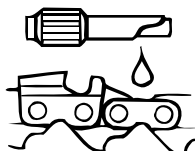

Oil pump capacity at
9,000 rpm,
ml/min

13

13



Oil tank capacity
Litres/US pints

0,25 / 0,53

0,25 / 0,53

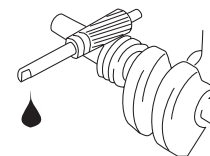

Automatic oil pump

Yes

Yes



Weight without
bar and chain
kg / lbs

435 II: 4,2 / 9,3

435e II: 4,4 / 9,7

440 II: 4,2 / 9,3

440e II: 4,4 / 9,7

440e II TB: 4,6 / 10,2

4 Special tools

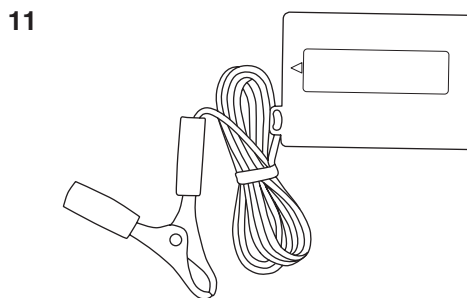
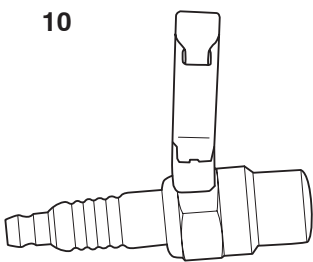
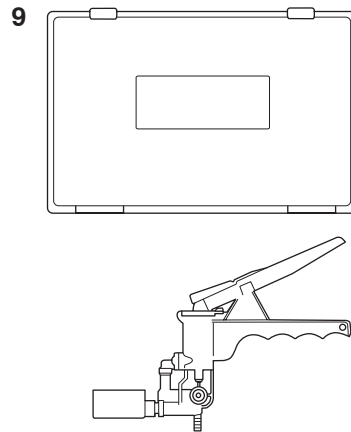
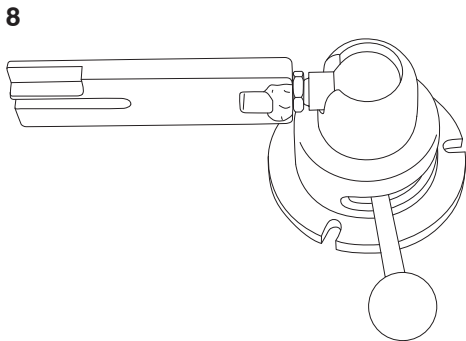
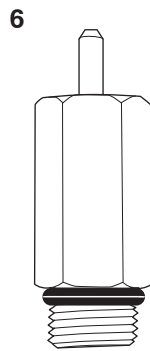
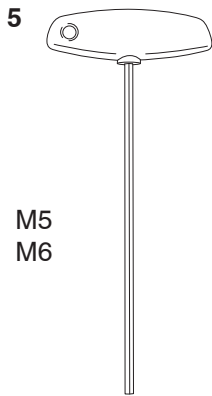
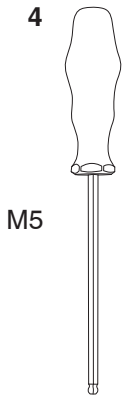
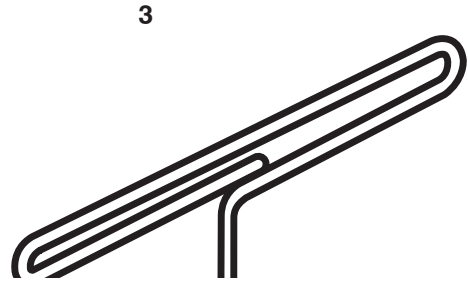
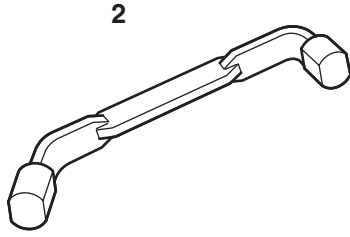
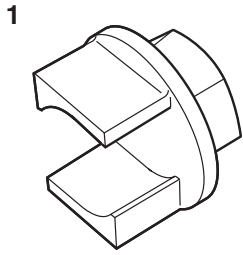

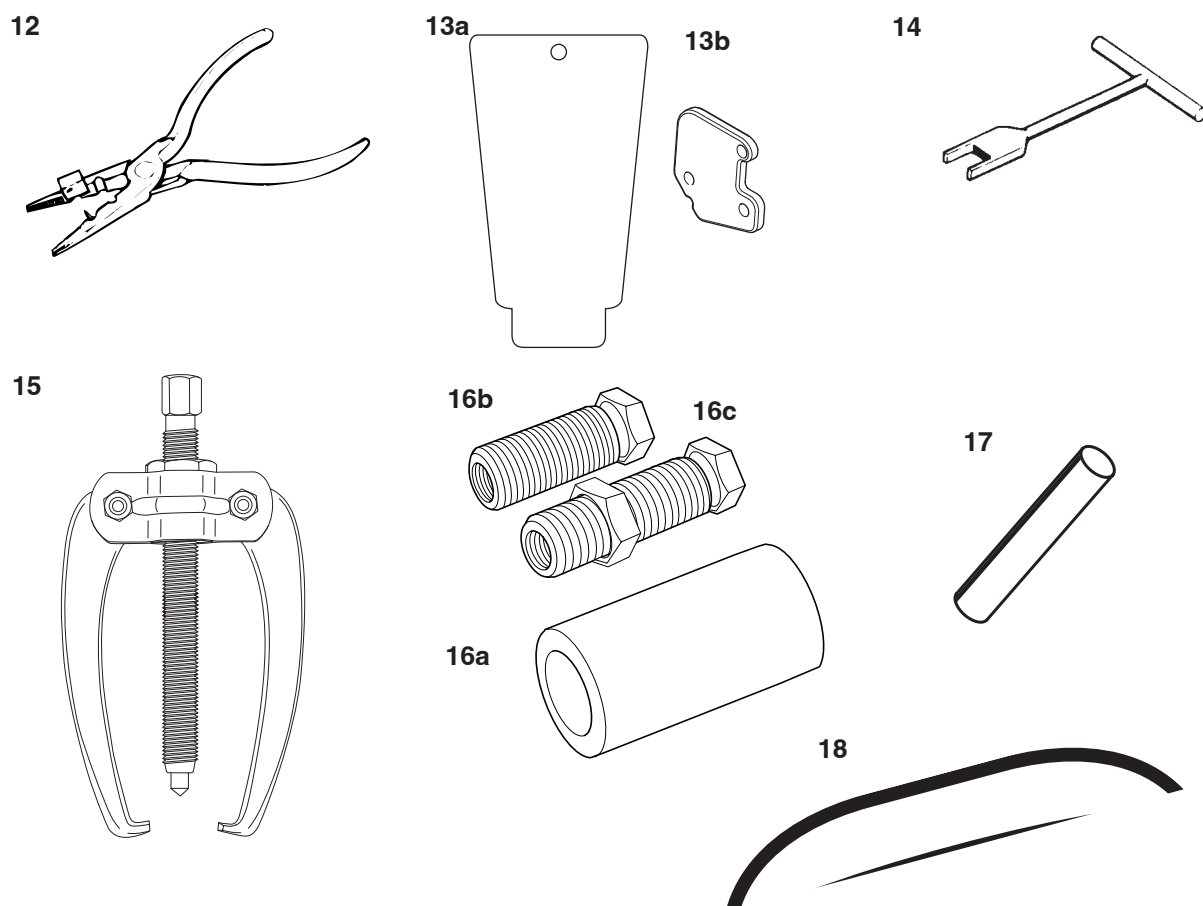

Item	Description	Used for	Order no.
1	Clutch tool	Centrifugal clutch	502 54 16-03
2	Piston stop	Locking the crankshaft	502 54 15-01
3	Fuel filter hook	Withdrawing the fuel filter	502 50 83-01
4	Allen key, 4mm	For M5 bolts	502 50 87-01
5	Allen key, 4mm	For M5 bolts	502 50 18-01
5	Allen key, 5mm	For M6 bolts	502 50 64-01
6	Pressure tester	Pressure testing cylinder	503 84 40-02
7	Feeler gauge	Adjusting ignition module	502 51 34-02
8	Assembly fixture	Assembling chain saw	502 51 02-01
9	Pressure gauge	Pressurisation during testing	531 03 06-23
10	Test spark plug	Checking the ignition module	501 97 64-01
11	Rev counter	Adjusting carburettor	502 71 14-01
12	Assembly pliers	Fitting spark plug guard	502 50 06-01
13a	Cover plate, exhaust	Sealing the exhaust port	502 54 11-02
13b	Cover plates, inlet	Sealing the intake manifold	504 63 93-01
14	Assembly tool	Assembling spring, chain brake	502 50 67-01
15	Puller	Pulling bearing of crankshaft	504 90 90-01
16a	Sleeve	Fitting crankshaft	502 50 30-22
16b	Shaft extension	Flywheel side	502 50 30-22
16c	Shaft extension	Clutch side	502 50 30-22
17	Punch	Dismantling the flywheel	502 51 94-01
18	Adjustment screwdriver	Adjustment of the carburettor	530 03 55-60

5 Service data

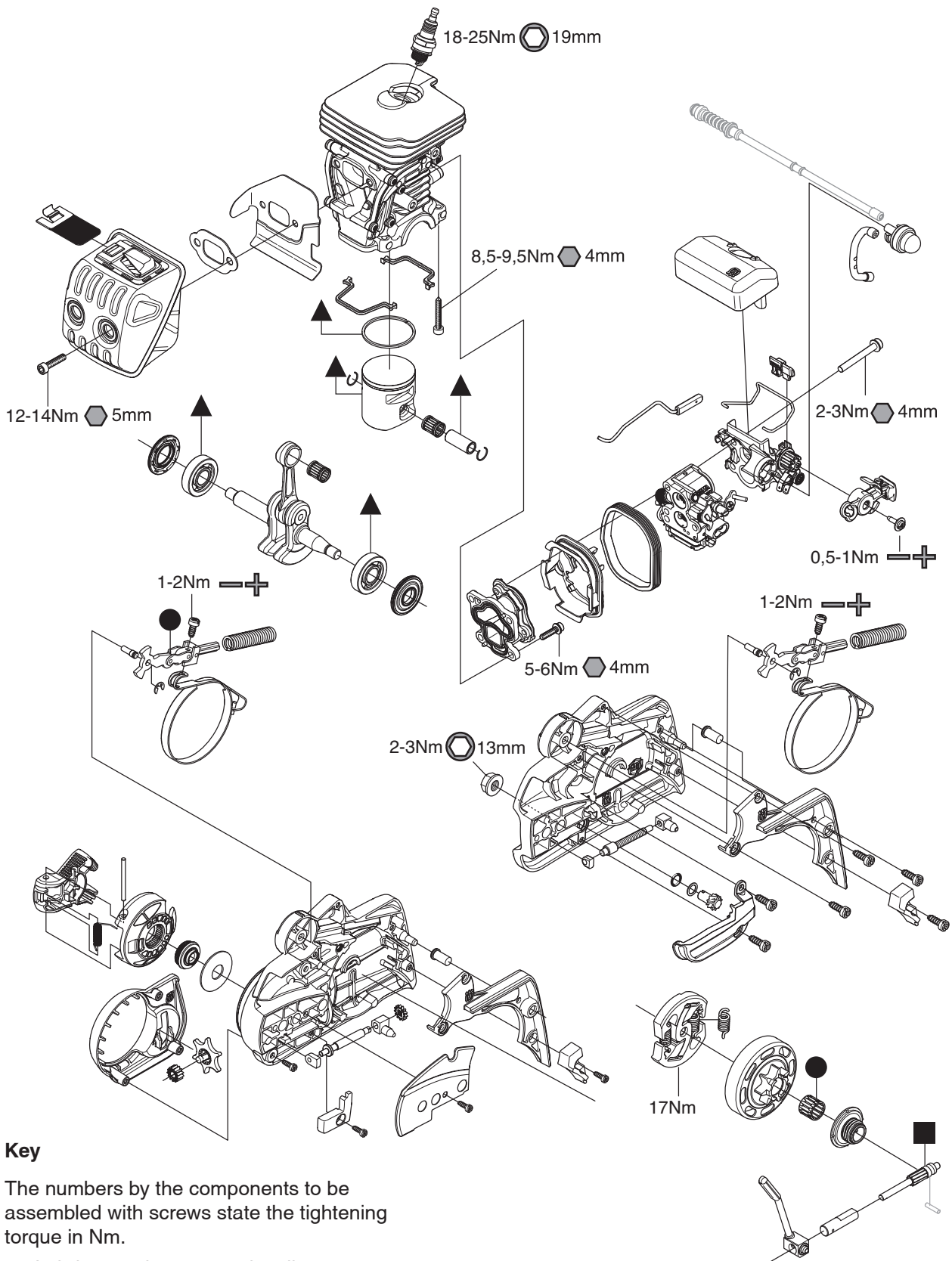

Key

The numbers by the components to be assembled with screws state the tightening torque in Nm.

s = Lubricate using two-stroke oil.

n = Lubricate using chain oil.

l = Lubricate using grease.

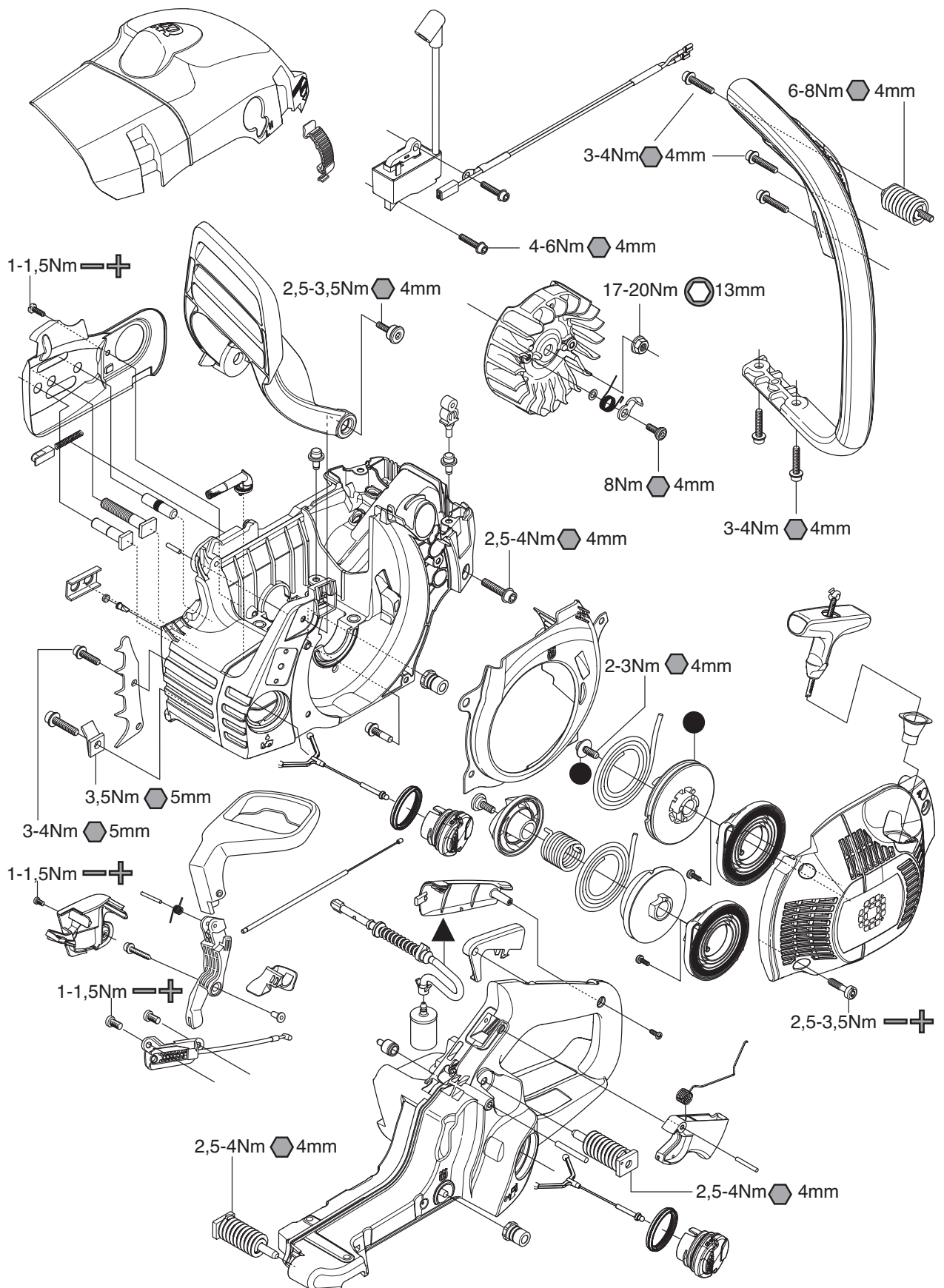

6 Safety equipment

Contents

6.1	Dismantling the chain brake	17
6.2	Chain brake - reassembly	18
6.3	Silencer - removal	19
6.4	Silencer - refitting	19
6.5	Chain catcher - replacement	20
6.6	Dismantling the start/stop control	20
6.7	Stop switch - resistance measurement	21
6.8	Assembling the start/stop control	21
6.9	Throttle lock, throttle trigger and return spring - removal	22
6.10	Throttle lock, throttle trigger and return spring - refitting	23

6 Safety equipment

6.1 Dismantling the chain brake



1

Release the brake by moving the front hand guard backward. Loosen the bar nut and remove the clutch cover, chain and bar (see figure 1).

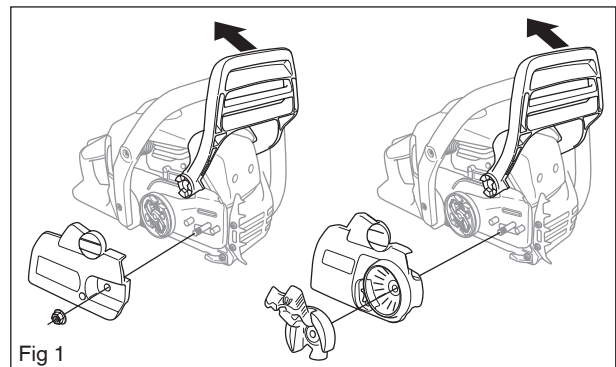

2

Carefully tighten the clutch housing in a vice. Release the brake by using the saw's front hand guard (A) as a tool. Mesh with the brake and tighten anti-clockwise until the brake is activated. (see figure 2)



WARNING!
Exercise care to ensure the spring does not fly out and cause personal injury. Wear protective glasses.

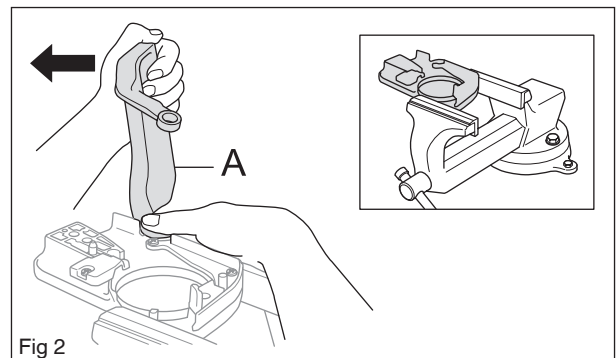

3

Loosen the screws and carefully remove the cover over the brake spring. (see figure 3)

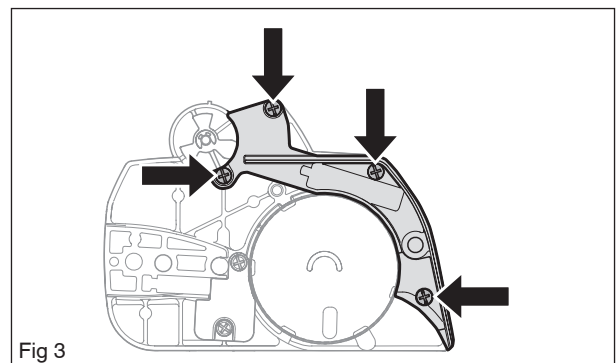

4

Hold one hand over the brake spring; press a narrow screwdriver in between the rear section of the spring and the clutch cover. Carefully pry upward until the spring releases and runs onto the screwdriver shaft. (see figure 4)

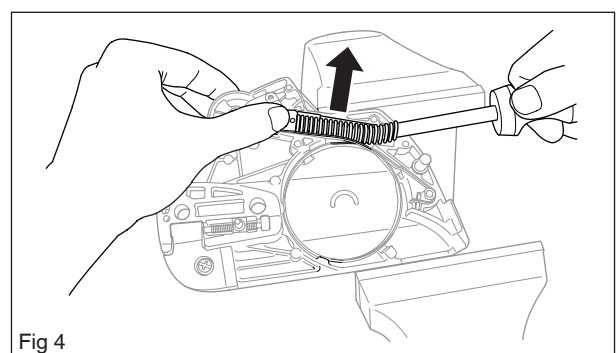

Cleaning and inspection

- Carefully clean and check all parts. Parts must be replaced if cracked or show signs of other defects. Always use original spare parts.
- Measure the thickness of the chain brake band. It must not be less than 0.6 mm at any point. (see figure 5)
- Lubricate the knee joint with grease.

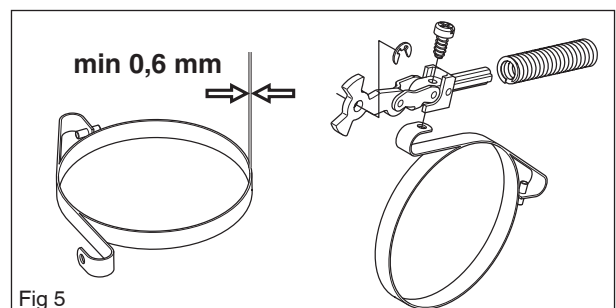

6.2 Chain brake – reassembly

1

Bolt the elbow joint to the brake band (see figure 5) and tighten to a torque of 1–2 Nm. Locate the elbow joint and connected brake band in their recesses in the clutch cover. Lubricate the recess for the spring with grease (see figure 6).

Secure the circlip (A) (see figure 6).

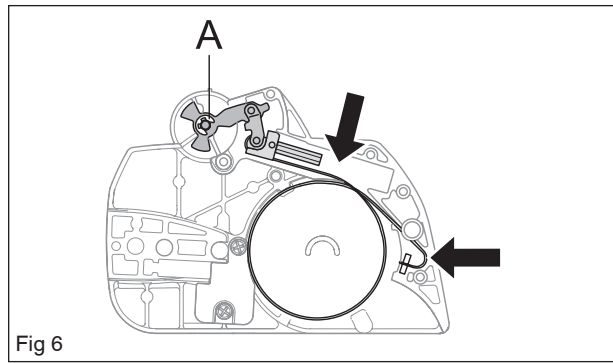

Fig 6

2

Grip the clutch cover in a vice. Compress the spring with special tool 502 50 67-01 and push it down with your thumb (see figure 7).



WARNING!
Make sure the spring does not fly out and cause injury. Wear eye protection.

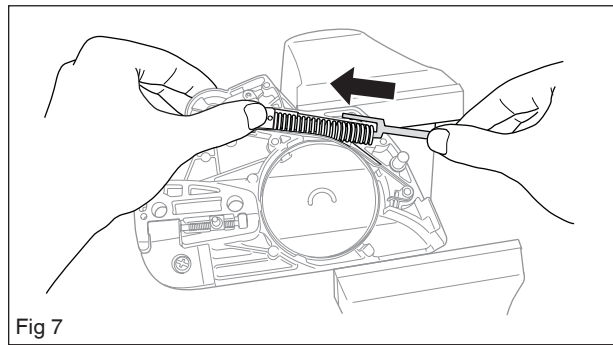

Fig 7

3

Fit the cover over the chain brake spring, tightening the screws to a torque of 1–1.5 Nm (see figure 8).

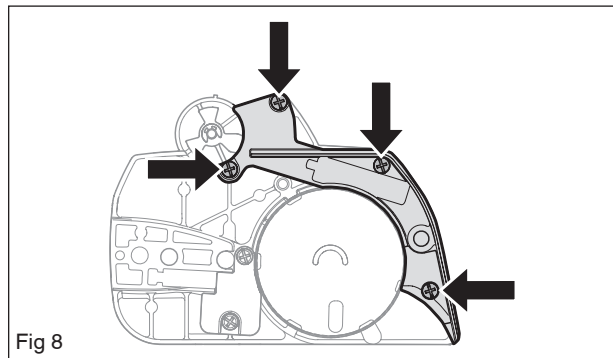

Fig 8

4

Tension the brake spring by using the kickback guard from the saw as a tool. Engage it with the brake mechanism and turn clockwise to release the brake (see figure 9).

5

Turn the chain tensioner anticlockwise as far as it will go.

Refit:

- guide bar
- chain
- clutch cover

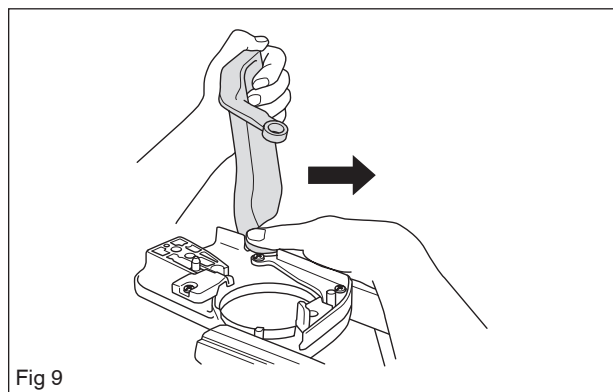

Fig 9

NOTE!

After completing the repair the chain brake must be tested as described below.

Operating test:

The engine must not be running during the test.

Guide bar length	Height
38cm/15"	50 cm/20"

- Hold the chainsaw over a firm surface. The height of the guide bar above the surface is given in the table above.
- Let go of the front handle and let the chainsaw fall towards the surface.
- When the guide bar hits the surface the chain brake must engage (see figure 10).

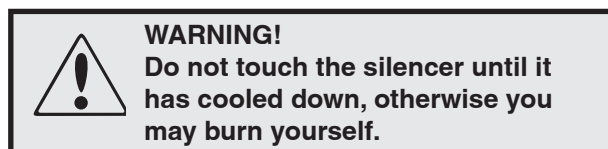

Fig 10

6.3 Silencer – removal**1**

Remove the cylinder cover, silencer, gasket and cooling plate.

2

If the saw is fitted with a spark arrestor mesh (A) this must also be removed. If necessary, use the combination spanner to push down the plate edge and remove the spark arrestor mesh (see figure 11).

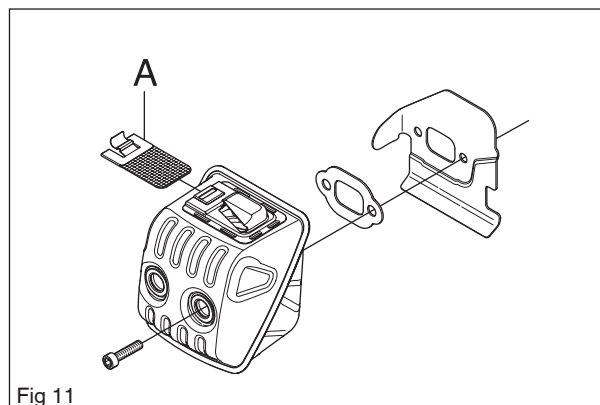

Fig 11

Cleaning and inspection

Clean and inspect all parts carefully. If there are any cracks or other defects replace the damaged parts with new ones.

The spark arrestor mesh is best cleaned with a wire brush. If the mesh is damaged it must be replaced. If the mesh is blocked the saw will overheat and this will cause damage to cylinder and piston.

Never use the saw with a silencer that is in poor condition. Always use original parts.

6.4 Silencer – refitting**1**

If the saw is equipped with a spark arrestor mesh this should be fitted first. When fitting the mesh, make sure that the mesh is inserted in the right position. If necessary, use the combination spanner to insert the mesh.

2

Refit

- cooling plate
- gasket
- silencer, tighten bolts to a torque of 12–14 Nm.
- cylinder cover

3

Run the saw for at least 1 minute, then retighten the silencer bolts to 12–14 Nm.

6.5 Chain catcher – replacement

If the chain catcher is worn it must be replaced with a new one.

1

Release the brake by pushing the kickback guard backwards. Undo the guide bar bolts and remove the clutch cover, chain and guide bar.

2

Remove the chain catcher and replace it with a new one. Check that the vibration damping spring locates correctly against the crankcase when you bolt the new chain catcher in position. (see figure 12)

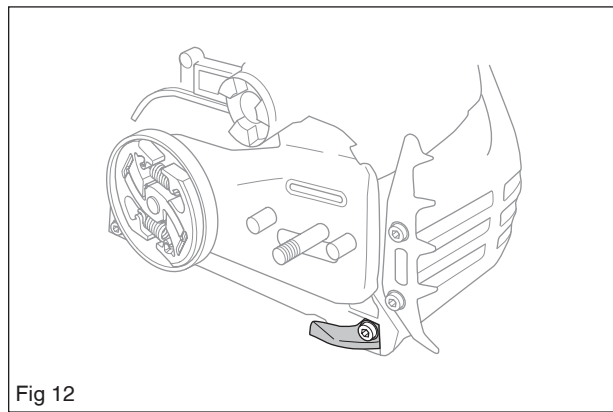

6.6 Dismantling the start/stop control

1

Remove the cylinder cover and air filter.

2

Loosen the screw and dismantle the control (see figure 13).

3

Loosen the filter holder from the rubber mountings (B). (see figure 13)

4

Cut off the starlock washer and pull out the control from the shaft on the filter holder. (see figure 14)

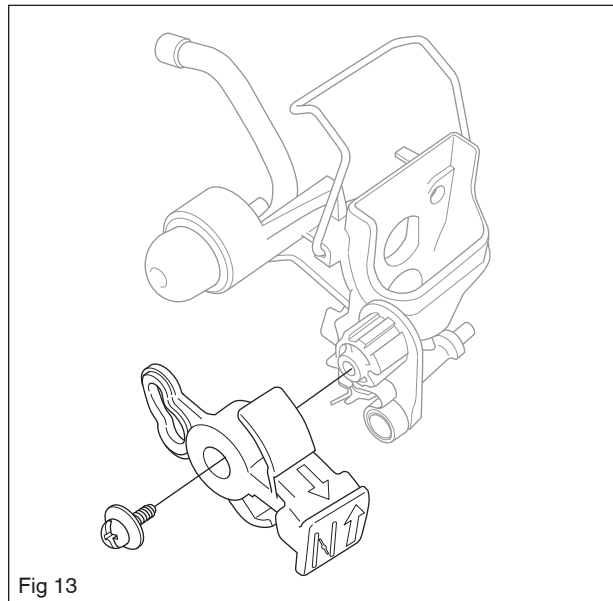

Cleaning and inspection

Clean and inspect all parts carefully. If there are any cracks or other defects replace the damaged parts with new ones. Always use original parts.

6.7 Stop switch – resistance measurement

Clean the mating surfaces and check the resistance as follows:

Measure the resistance by connecting a multimeter to the ignition coil. NOTE! The switch must be in the “on” (A) position to give the correct reading (see figure 14).

The resistance must not be higher than 0.5 Ohm when the switch is in the on position.

The stop switch is in the on position when the button is held down (A) (see figure 14) and in the off-position the button is neutral (B) (see figure 15).

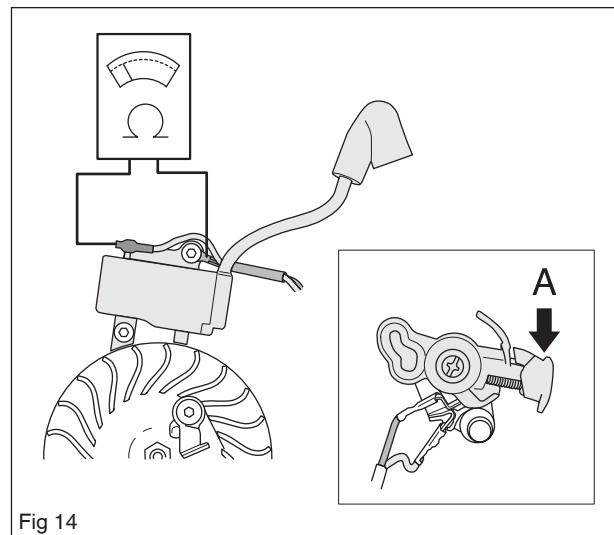

Fig 14

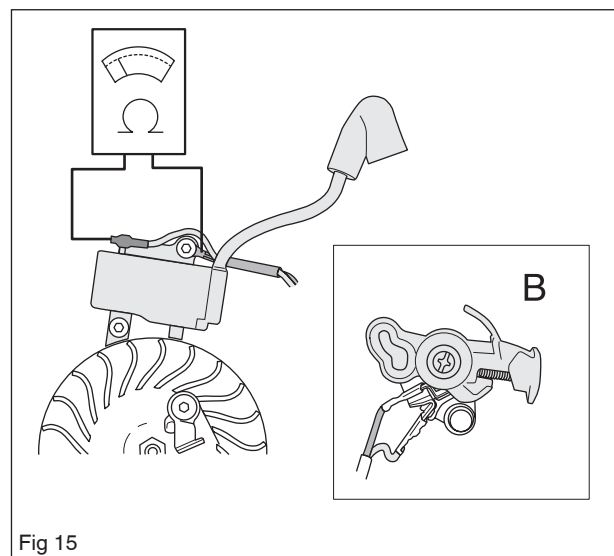

Fig 15

6.8 Assembling the start/stop control

1

Fit a new control and tighten the screw.

2

Fit air filter and cylinder cover.

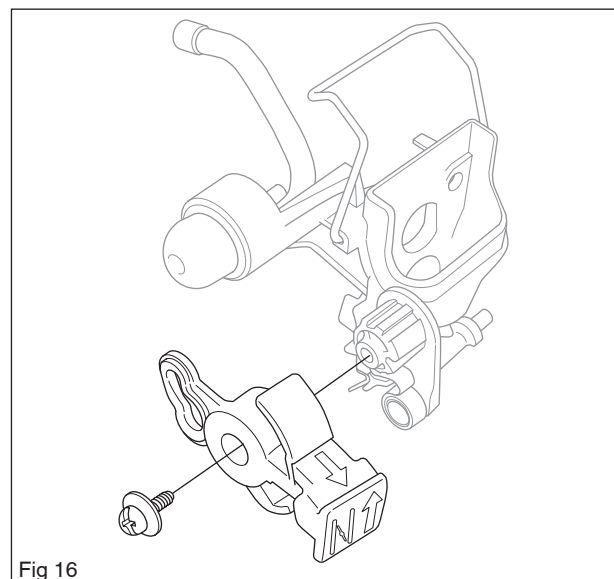

Fig 16

6.9 Throttle lock, throttle trigger and return spring – removal

1
Loosen the throttle actuator rod on the carburettor, the fuel hose and the suction hose to the fuel pump.

2
Dismantle the tank unit from the engine unit by loosening the screws A (see figure 17)

3
Dismantle the handle insert (B) by loosening the screw C on the handle (see figure 18).

4
Press out the throttle control pin (D) with the help of a punch (see figure 19).

5
Loosen the throttle lock as illustrated with the help of a screwdriver or the like. Then dismantle from the shaft in the handle (see figure 20).

6
Dismantle the throttle control (see figure 20).

7
Now loosen the spring.

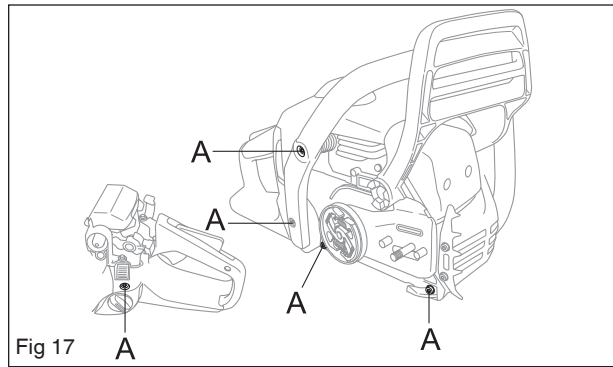

Fig 17

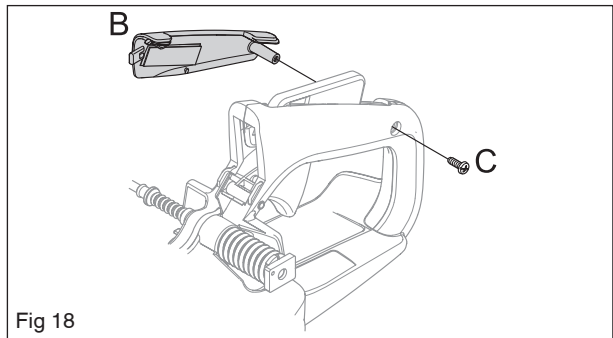

Fig 18

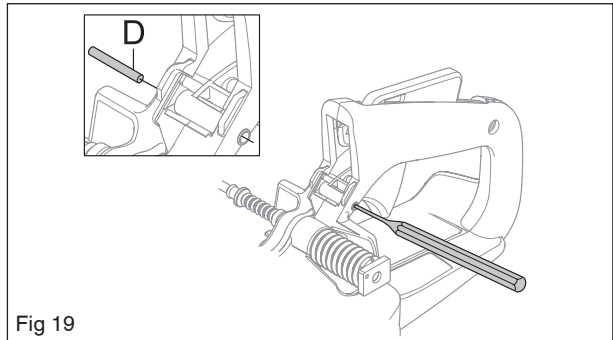

Fig 19

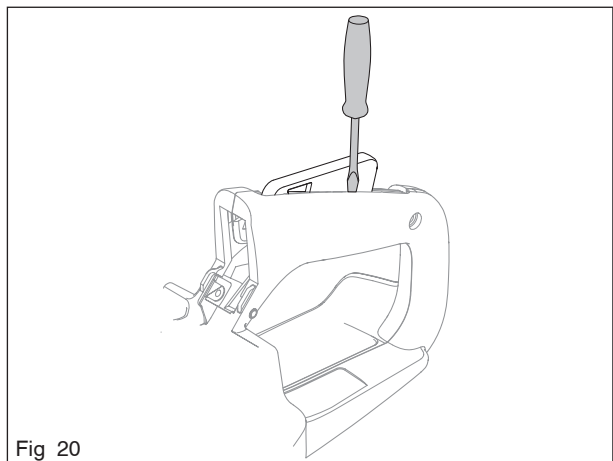

Fig 20

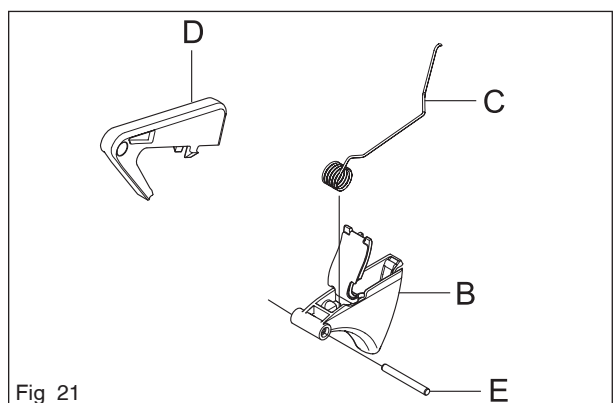

Fig 21

Cleaning and inspection

- Clean and inspect all parts carefully. If there are any cracks or other defects replace the damaged parts with new ones. Always use original parts.
- Check that the spring is not broken and has not lost its tension.

6.10 Throttle lock, throttle trigger and return spring – refitting

1

Lubricate all pins and mating surfaces with a light oil.

2

Fit the throttle control (B) and spring (C) (see figure 22).

3

Hold the spring and insert the throttle lock into the cut-out in the handle (see figure 23).

4

Fit the throttle control pin (E) with the help of a punch. (see figure 23)

5

Fit the throttle lock (D) by pressing it onto the shaft in the handle (see figure 24).

6

Assemble the handle insert using a screw, when the throttle control, lever, throttle cable and throttle control lock with pin are fitted correctly (see figure 25).

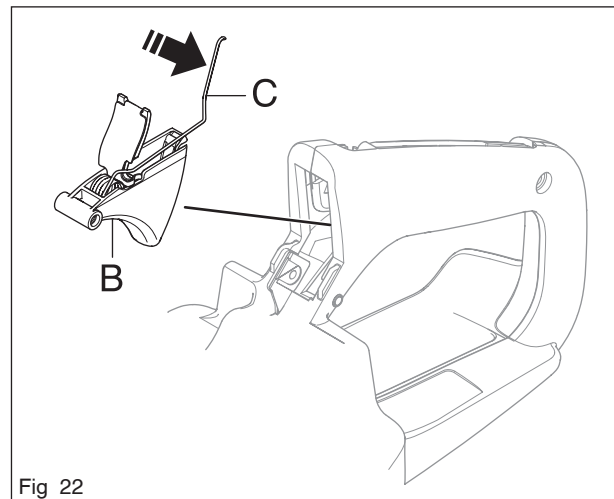

Fig 22

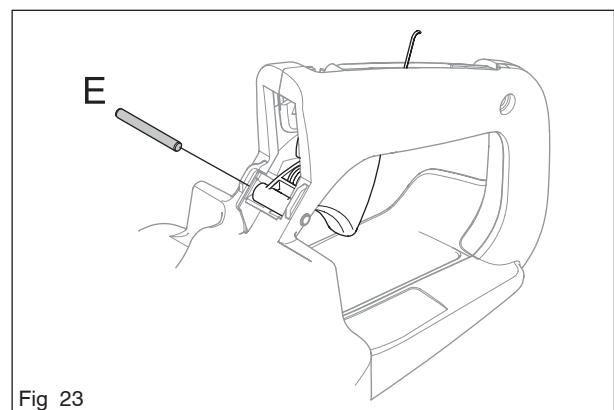

Fig 23

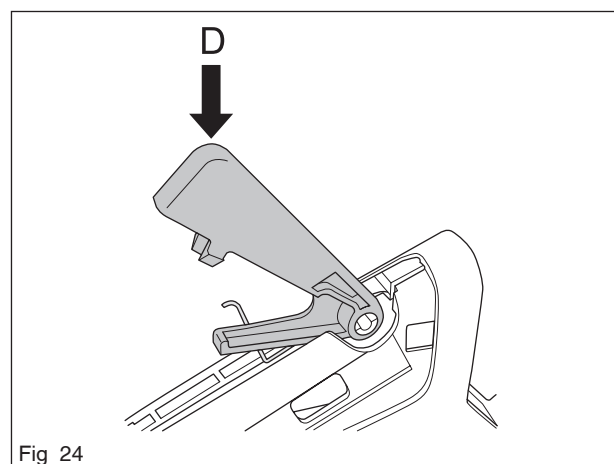

Fig 24

7 Repair instructions

Contents

7.1	Starter assembly - removal	25
7.2	Changing a broken or worn starter cord	26
7.3	Tensioning the recoil spring	26
7.4	Replacing a worn recoil spring	27
7.5	Starter assembly - refitting	27
7.6	Ignition module - testing	27
7.7	Ignition module and flywheel - removal	28
7.8	Ignition module and flywheel - refitting	29
7.9	Centrifugal clutch - removal	30
7.10	Centrifugal clutch - refitting	31
7.11	Dismantling the oil pump and screen	31
7.12	Assembling the oil pump and screen	32
7.13	Air intake system - removal	32
7.14	Assembling the intake system	32
7.15	Carburettor	33
7.16	Tank unit	42
7.17	Venting the fuel tank	42
7.18	Vibration damping system	43
7.19	Replacing the fuel filter	44
7.20	Replacing the fuel hose/return hose	44
7.21	Replacing the air-purge	44
7.22	Piston and cylinder - removal	45
7.23	Piston and cylinder - refitting	47
7.24	Cylinder - pressure testing	49
7.25	Crankshaft complete - dismantling	50
7.26	Crankshaft bearings - replacement	50
7.27	Crankshaft complete - reassembly	51
7.28	Repairing damaged threads	51
7.29	Replacing the bar bolt	52

7 Repair instructions

7.1 Starter assembly – removal

1

Undo the four bolts that fasten the starter assembly to the crankcase and lift off the starter assembly. (see figure 1)

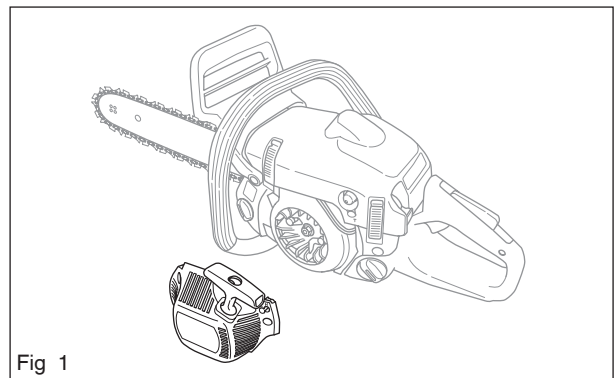

Fig 1

2

Pull out about 30 cm of the cord and fasten it in the notch in the pulley rim. Release the tension in the return spring by letting the pulley wind backwards slowly. (see figure 2)



WARNING!
If the recoil spring is still under tension when the pulley is removed it can fly out and cause injury. Wear eye protection.



3

Remove the bolt from the centre of the pulley and lift off the pulley. (see figure 3)

Cleaning and inspection

Clean the parts and check the following:

- The starter cord.
- That the pawls on the flywheel are undamaged, i.e. that they spring back towards the centre and move freely.
- Lubricate the return spring with light oil.

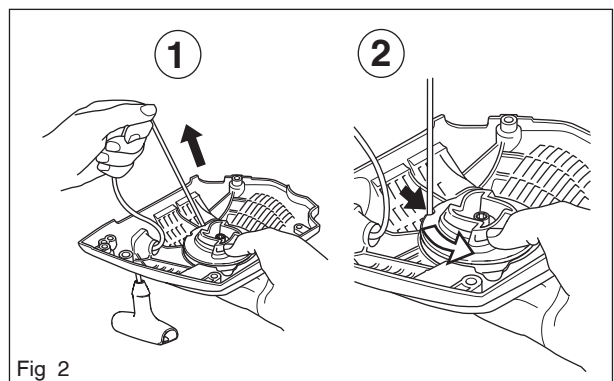

Fig 2

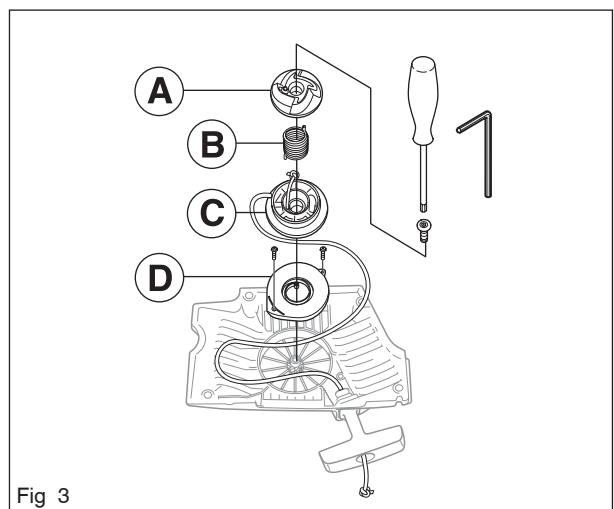

Fig 3

7.2 Changing a broken or worn starter cord

When the starter cord is worn and must be replaced, the tension on the return spring must be released.

1

Pull the cord out about 30 cm and lift it into the notch on the outside of the starter pulley. Release the tension on the return spring by allowing the starter pulley to rotate slowly backwards (see figure 2).



WARNING!

If the spring tension is activated on the starter pulley, the spring can fly out and cause personal injury. Wear protective glasses.

2

Undo the bolt in the centre of the pulley and remove the pulley (see figure 3).

3

Fit a new cord through the hole in the pulley and tie a knot to secure it. Feed the other end of the cord through the hole in the starter housing and through the starter handle, then tie a double knot in the end. Wind about 3 turns of the starter cord onto the pulley. Fit the bolt through the centre of the pulley and tighten to a torque of 2–3 Nm.

Cleaning and inspection

- Clean and inspect all parts carefully. If there are any cracks or other defects replace the damaged parts with new ones. Lubricate the return spring with a little grease.

7.3 Tensioning the recoil spring

1

Fasten the starter cord in the notch in the pulley rim and wind the pulley about 3 turns clockwise. Check that the pulley is free to rotate at least another half turn when the starter cord is fully extended (see figure 4).

2

Tension the cord with the handle. Remove the thumb and released back the cord (see figure 5).

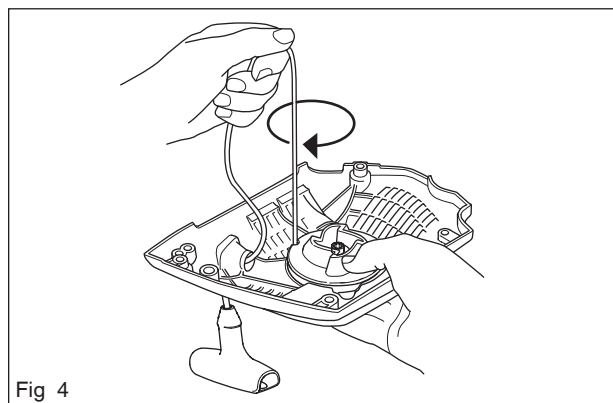

Fig 4

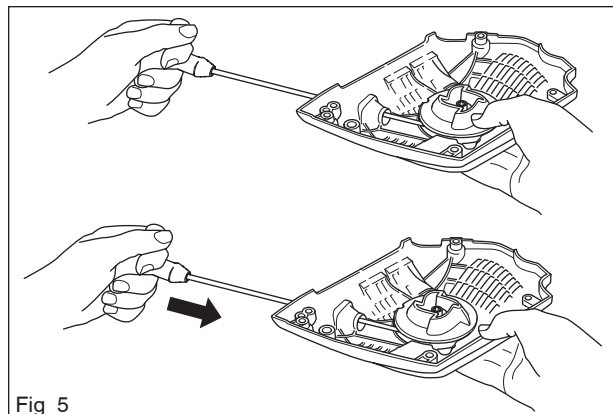

Fig 5

7.4 Replacing a worn recoil spring



WARNING!
Make sure the recoil spring does not fly out and cause injury. Wear eye protection..



1

Remove the bolt from the centre of the pulley and lift off the pulley and spring cassette.

2

Replace the defective spring cassette with a new one.

3

Fit the bolt through the centre of the pulley and tighten to a torque of 2–3 Nm. Tension the recoil spring, see “Tensioning the recoil spring”.

7.5 Starter assembly – refitting

1

Position the starter assembly on the crankcase and tighten the bolts to a torque of 2.5–3.5 Nm.

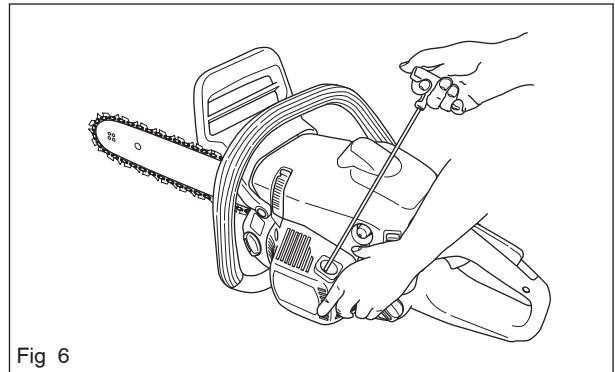

Fig 6

7.6 Ignition module – testing

If there is a fault in the ignition system the ignition module must be tested before the ignition system is removed.

Test the ignition module as follows:

- Connect a test spark plug 502 71 13-01 to the ignition lead and clip the test spark plug onto the cylinder.
- Turn the engine over using the starter cord.
- If the test spark plug produces a spark the ignition module is OK. (see figure 7)

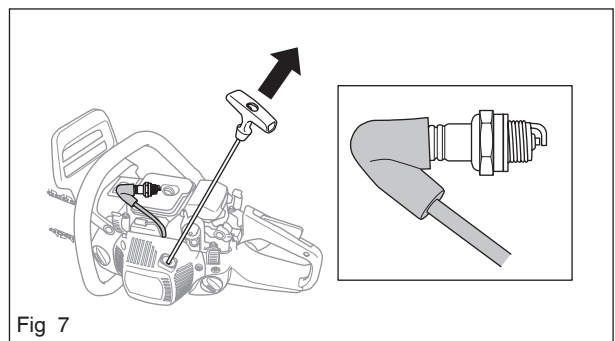

Fig 7

7.7 Ignition module and flywheel

– removal

1

Remove the cylinder cover. Disconnect the HT lead, remove the spark plug and fit piston stop 502 54 15-01. in its place. Take off the starter assembly, release the leads from the cable guide and remove it (see figure 8).

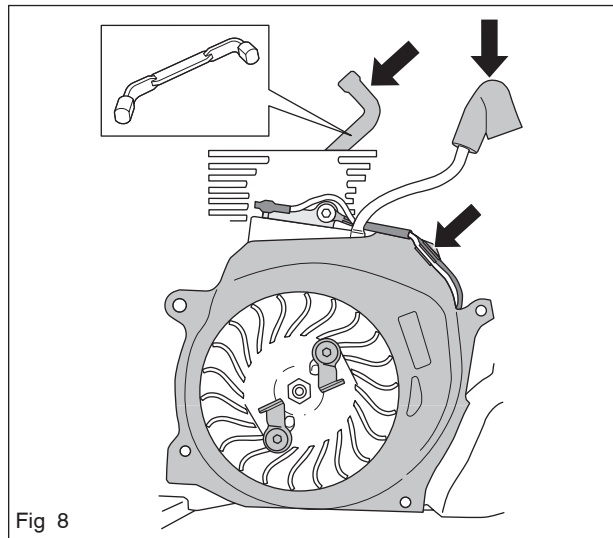

Fig 8

2

If replacing the ignition module (B), loosen the cable lug (C) and screw (A) and unscrew it. The ignition module can be left in place if you are simply removing the flywheel (see figure 9).

3

Loosen the flywheel nut (E) using a suitable socket and remove it (see figure 10).

When replacing the cables, they are fitted on the stop switch, as shown in figure (see figure 9).

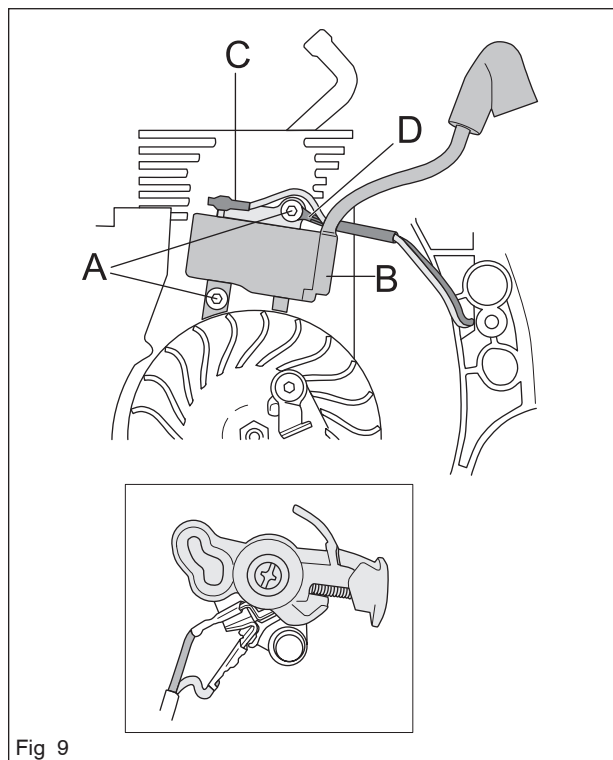

Fig 9

4

Knock on the punch using a metal mallet until the flywheel releases from the shaft. Remove the punch and the flywheel (see figure 10).

Cleaning and inspection

- Clean all parts, especially the tapers on the flywheel and shaft.
- Check that the flywheel is not cracked or damaged in any other way.

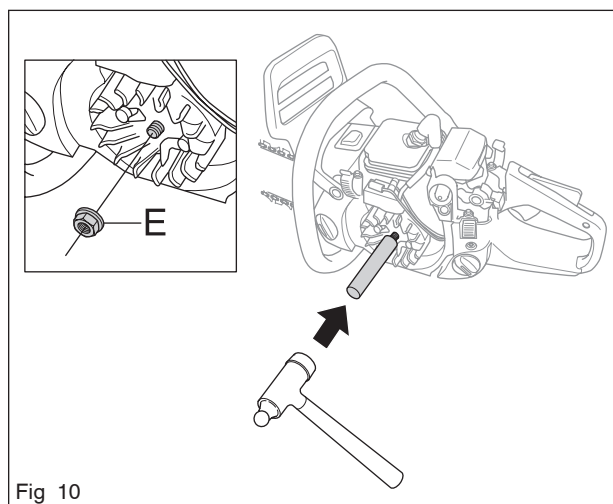

Fig 10

7.8 Ignition module and flywheel – refitting

1

Fit the flywheel on the crankshaft journal. Turn the flywheel so that the key lines up with the keyway in the shaft.

Fit the nut on the shaft and tighten to a torque of 17-20 Nm (see figure 11).

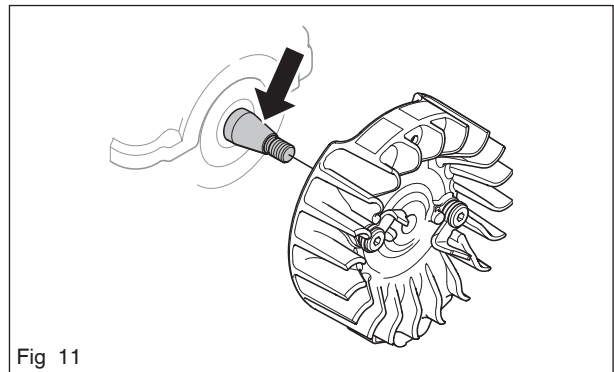

Fig 11

2

To refit the ignition module proceed as follows:

Turn the flywheel so that the magnets are in line with the ignition module. Fit the ignition module with the plastic feeler gauge (502 51 34- 02) held in position at the same time, without tightening the bolts. Fit the earth cable (black) (A). Set a distance of 0.3 +/- 0.1 mm, between the ignition module and magnet. The measurement applies to the two lowest lugs on the ignition module. Tighten the screws, tightening torque 4–6 Nm. Fit the blue cable on the ignition module (see figure 12).

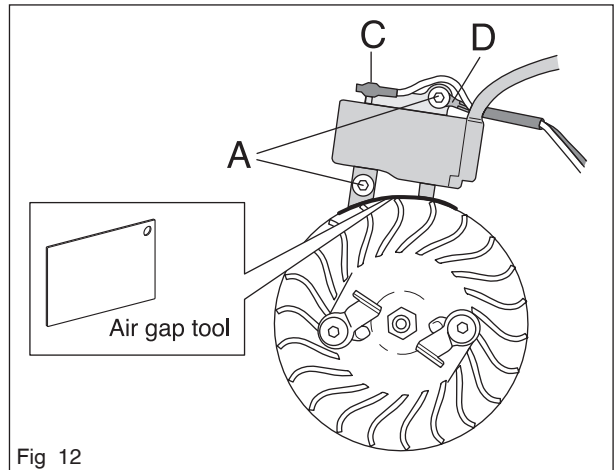

Fig 12

3

Then refit:

- cable guide and press the leads into position
- HT lead
- starter assembly, tighten to a torque of 2.5–3.5 Nm
- cylinder cover

When replacing the cables, they are fitted on the stop switch as shown in middle figure on the previous page.

7.9 Centrifugal clutch – removal

1

Remove the cylinder cover. Disengage the chain brake by pushing the kickback guard backwards. Undo the bar nut and remove the clutch cover, bar and chain (see figure 13).

2

Disconnect the HT lead. Remove the spark plug and fit piston stop 502 54 15-01 (A) in its place (see figure 14).

3

Unbolt the clutch using tool 502 54 16-03 (B) and a suitable socket or wrench. Turn the clutch clockwise to remove it (see figure 15).

4

Secure the clutch in a vice as shown in figure. Carefully release the clutch springs (C) (see figure 16).

NOTE!

Handle the clutch springs carefully. If they are opened up too much they could damage the saw.

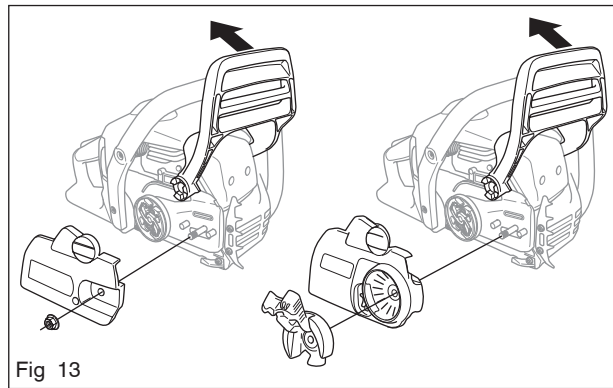

Fig 13

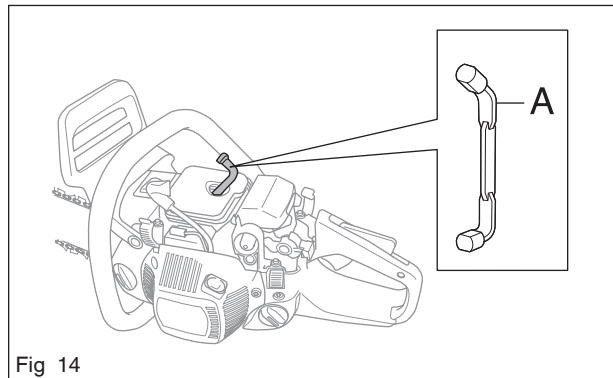

Fig 14

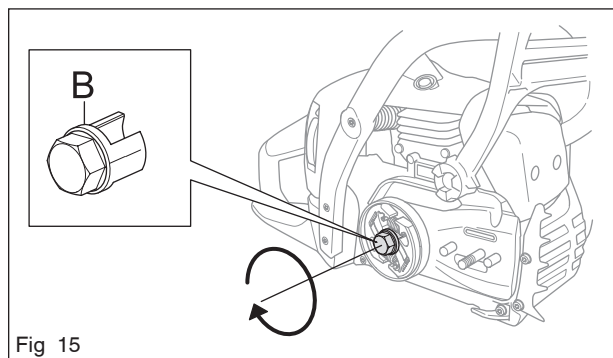

Fig 15

Inspection and cleaning

- Clean and inspect all parts carefully. If there are any cracks or other defects replace the damaged parts with new ones. Always use original parts.
- Check the thickness of the clutch shoes by using vernier callipers to measure the diameter of the clutch. If the diameter is less than 60 mm the clutch assembly must be replaced (see figure 16).

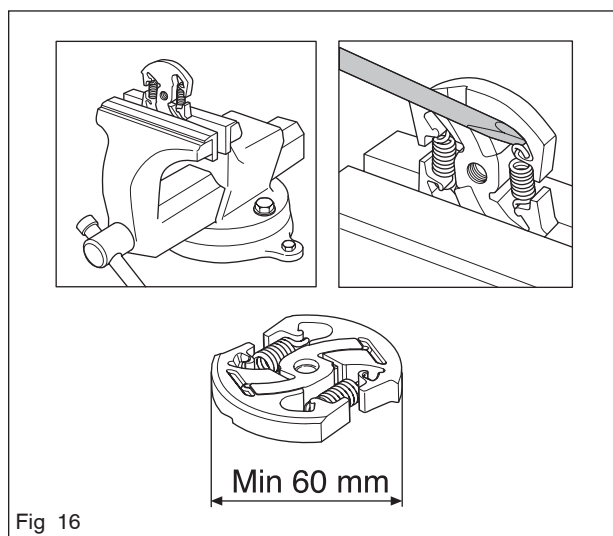

Fig 16

7.10 Centrifugal clutch – refitting

1

Insert the clutch springs in the shoes.

2

Screw the clutch (anti-clockwise) until it stops. Now tighten using tool 502 54 16-03 and a suitable socket wrench or combination spanner. Tightening torque 17 Nm.

3

Remove the piston stop. Fit the spark plug, tightening it to a torque of 20 Nm, then connect the HT lead.

Then refit:

- cylinder cover
- guide bar
- chain
- clutch cover

7.11 Dismantling the oil pump and screen

1

Empty and clean the oil tank.

Remove the cylinder cover. Release the brake by moving the front hand guard backward. Undo the bar nut and remove the clutch cover, bar and chain. Loosen spark plug cap and remove the spark plug, fit the piston stop 502 54 15-01. Loosen the clutch (clockwise) using tool 502 54 16-03 and a suitable socket wrench or combination spanner.

2

Remove the centrifugal clutch (A). Remove the clutch drum (B), needle bearing (C) and pump drive wheel (D) (see figure 17).

3

Unscrew the chain guide plate (see figure 18).

4

Unbolt the oil pump from the crankcase and remove it together with the oil pressure hose (see figure 19).

5

The oil pump (E) is not adjustable (see figure 20).

Cleaning and inspection

- Clean and inspect all parts carefully. If there are any cracks or other defects replace the damaged parts with new ones. Always use original parts.
- Lubricate all moving parts with chain oil.

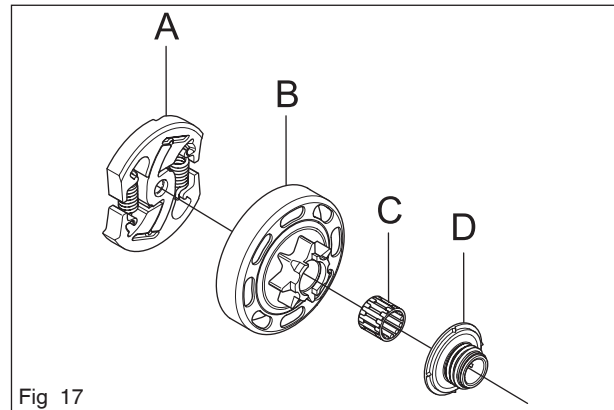

Fig 17

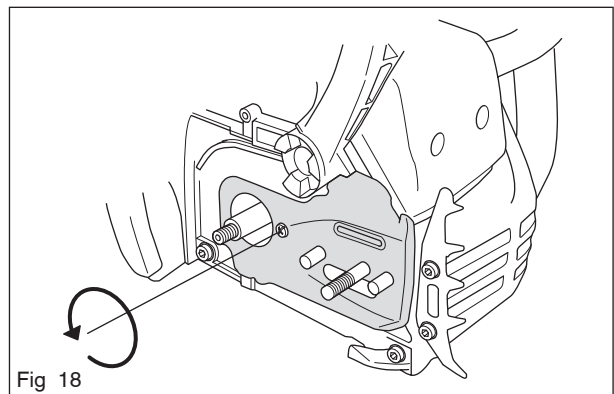

Fig 18

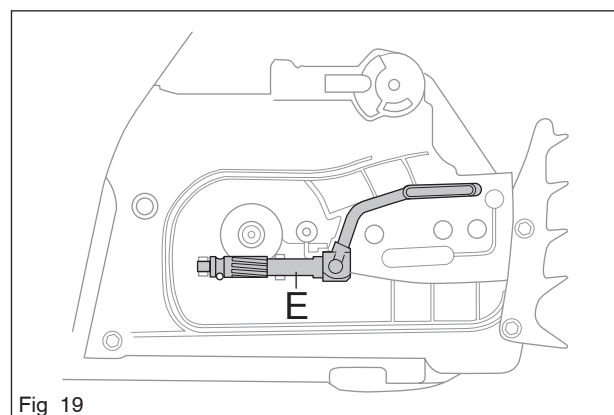

Fig 19

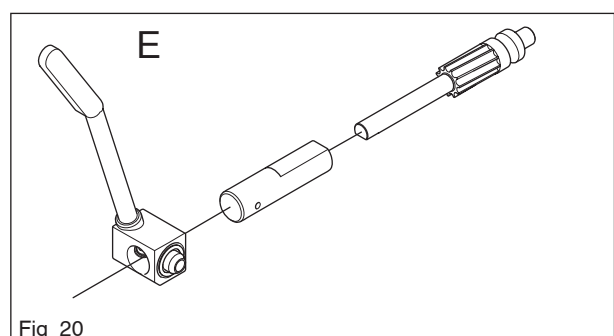

Fig 20

7.12 Assembling the oil pump and screen

1

Fit the chain guide plate with tightening torque 1–1.5 Nm.

Fit the drive gear, needle bearing, clutch drum and the clutch (min. 20 Nm).

Fit the chain, bar and clutch cover.



WARNING!
Poor chain lubrication can result in failure of the chain, which could cause serious or fatal injury.

7.14 Assembling the intake system

1

Fit the intake manifold (A) and the partition walls (B and C) on the cylinder using tool 502 50 87-01 (see figure 21).

Cleaning and inspection

Clean and check all parts carefully. Parts must be replaced if cracked or show signs of other defects. Always use original spare parts.

7.13 Air intake system – removal

The air intake system comprises:

- intake manifold (A)
- plastic partition wall (B)
- rubber partition wall (C)

(see figure 21)

1

Now loosen the screws using tool 502 50 87-01..

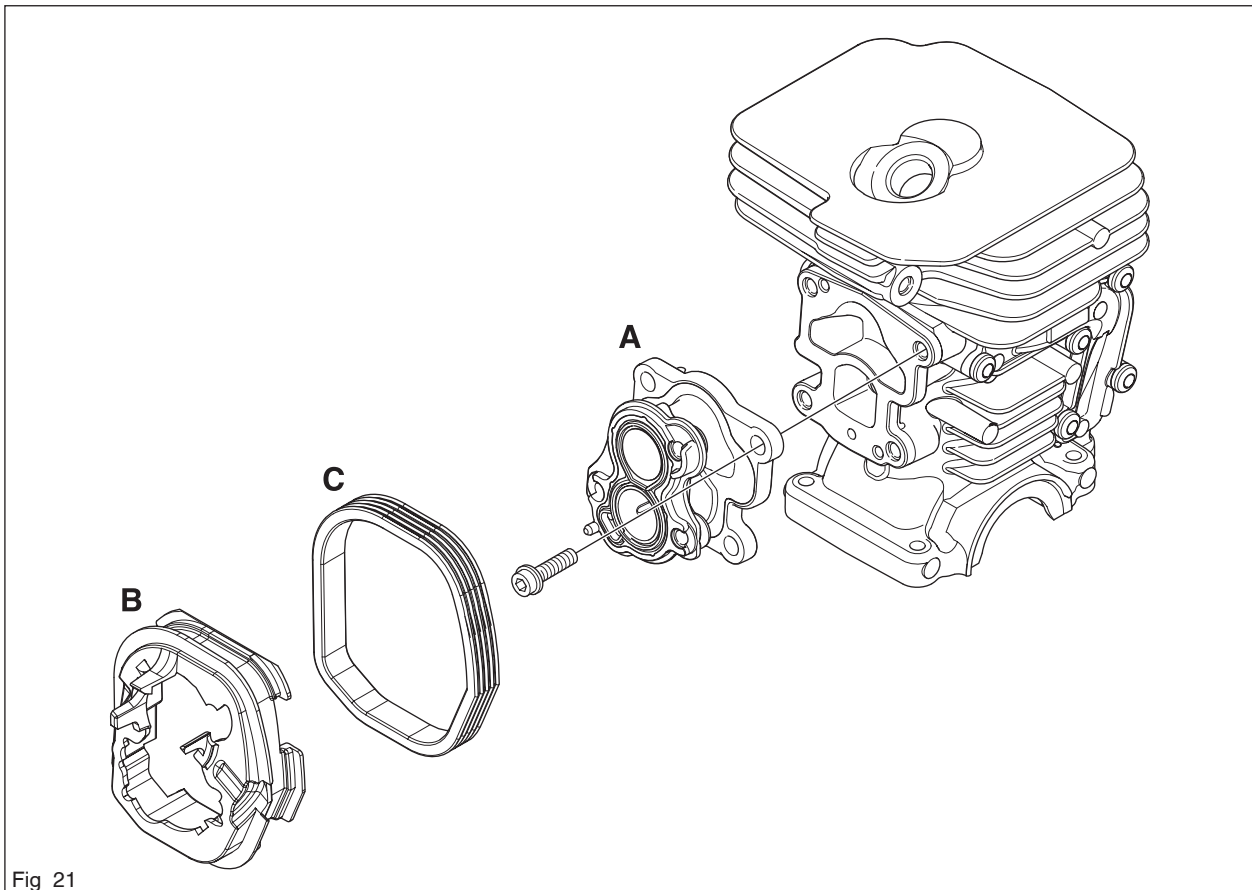

Fig 21

7.15 Carburettor



WARNING!

The fuel used in the chainsaw has the following hazardous properties:

1. The fluid and its fumes are poisonous.
2. Can cause skin irritation.
3. Is highly inflammable.

Description

The drawings accompanying this description do not correspond with the carburettor on the chainsaw. They only show the principle for the design and function.

Design

The carburettor is based on three sub-systems:

- The metering unit, A.
- The mixing venturi, B.
- The pump unit, C.

The jets and the fuel's control functions are located in the metering unit (A). Here the correct quantity of fuel is adjusted for the actual speed and power output (see figure 22).

The mixing venturi (B) houses the choke, throttle valve and diffuser jets. Here air is mixed with the fuel to give a fuel/air mixture that can be ignited by the ignition spark (see figure 23).

In the pump unit (C), fuel is pumped from the fuel tank to the metering unit. One side of the pump diaphragm is connected to the crankcase and pulses in time with the pressure changes in the crankcase. The other side of the diaphragm pumps the fuel

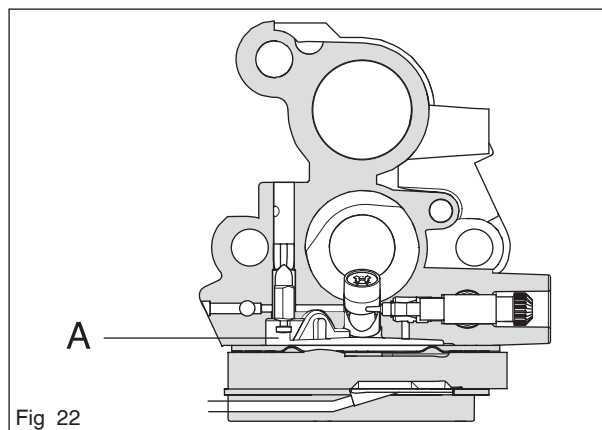

Fig 22

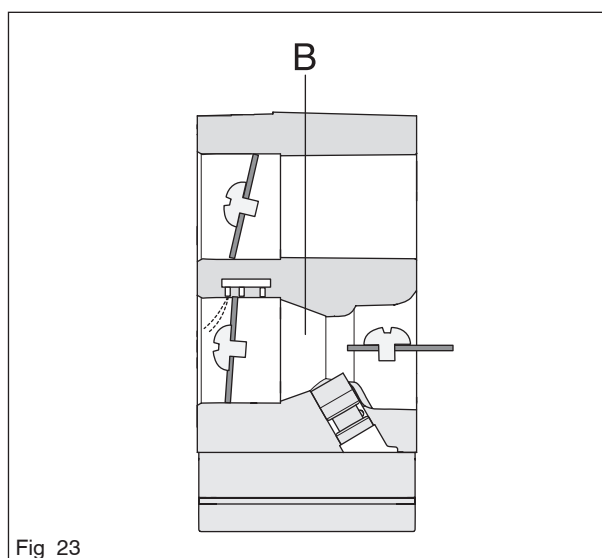

Fig 23

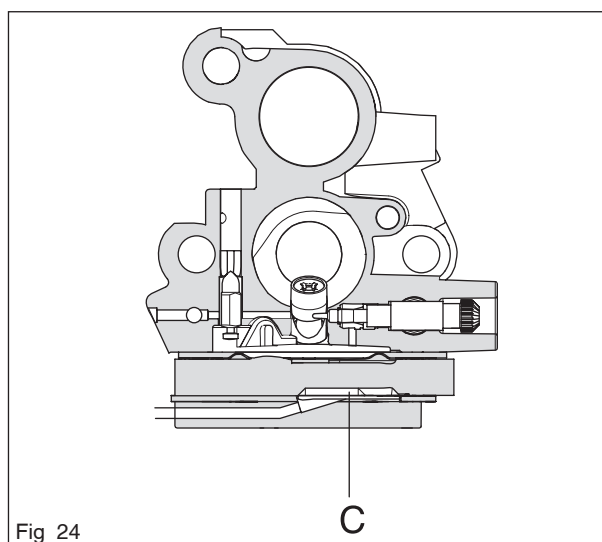

Fig 24

Function

The carburettor operates differently in the following modes:

- Cold start mode
- Idling mode
- Part throttle mode
- Full throttle mode

In the cold start mode (see figure) the choke valve (H) is fully closed. This increases the vacuum in the carburettor so that fuel is sucked more easily from all the diffuser jets (D, E and F). The throttle valve (I) is partly open. Extra air inlet (J) is closed (see figure 25).

In the idling mode (see figure) the throttle valve (I and J) is closed and the choke valve (H) is open.

Air is sucked in through an aperture in the throttle valve and a small amount of fuel is supplied through the diffuser jet (D) (see figure 26).

In the part throttle mode (see figure below) the throttle valve (I) is partially open and the choke valve (H) is open. Fuel is supplied through the diffuser jets (D and E). The throttle valve (J) starts to open (see figure 27).

In full throttle mode (see figure below) all valves are open and fuel is supplied through all diffuser jets (D, E, F and G). Extra air inlet (J) is also fully opened (see figure 28).

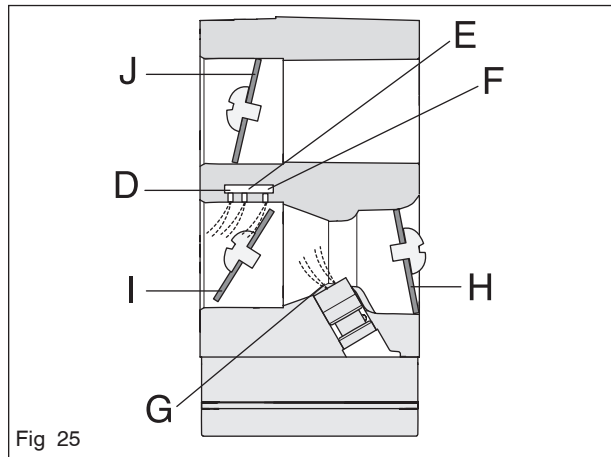

Fig 25

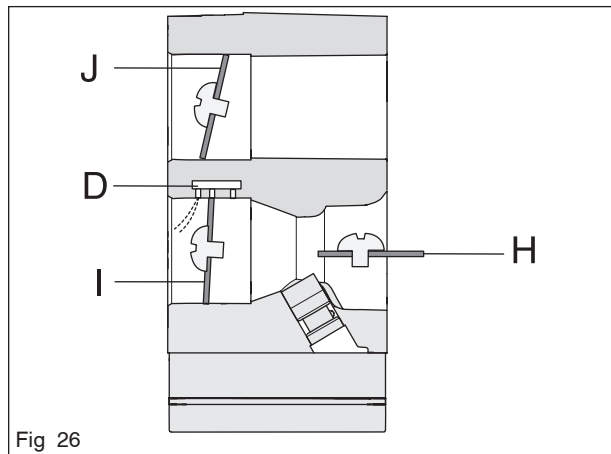

Fig 26

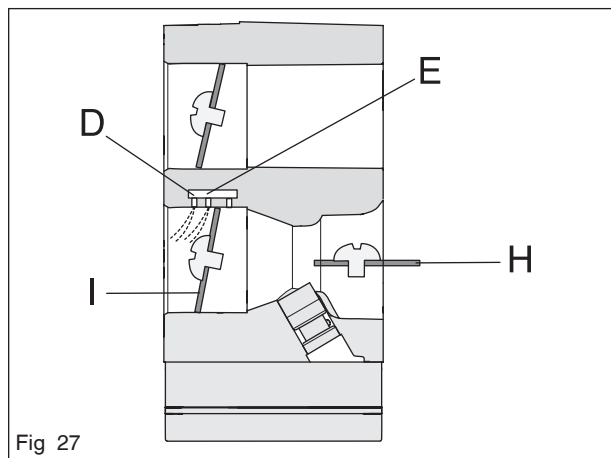

Fig 27

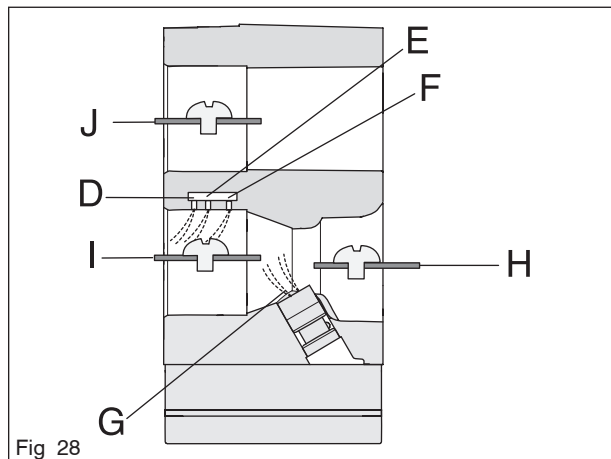

Fig 28

Dismantling the carburettor

1. Dismantle the cylinder cover and the air filter.
2. Disassemble the handle holder (see figure 29).

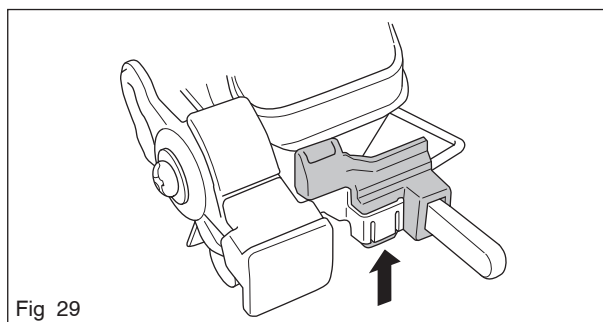

Fig 29

3. Push the throttle actuator rod out of the handle part. Unhook it from the carburettor (see figure 30).

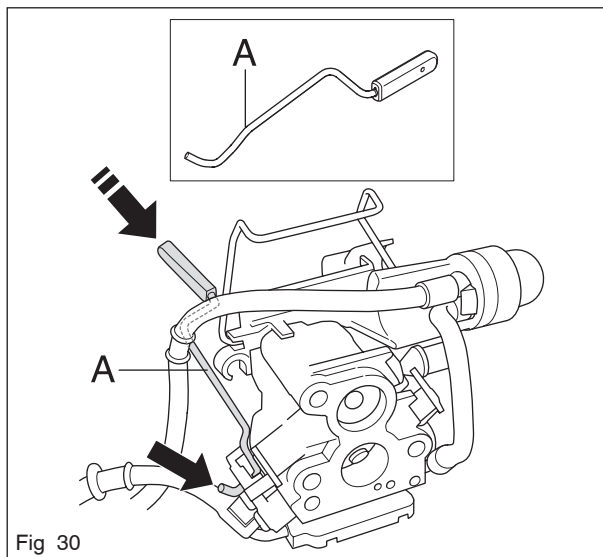

Fig 30

4. Remove the return hose (B) and suction hose (C). Loosen the fuel pump (D). Let the fuel hose (G) remain in place (see figure 31).

NOTE!

Take care when lifting out the carburettor so that the fuel hose does not become loose.

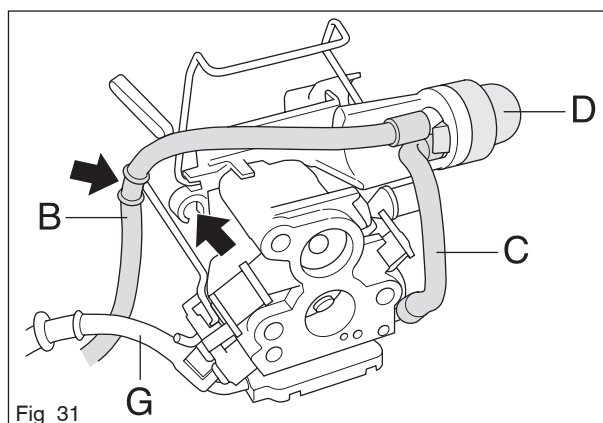

Fig 31

5. Loosen the screws (E) and unhook the rubber mountings (F) (see figure 32).

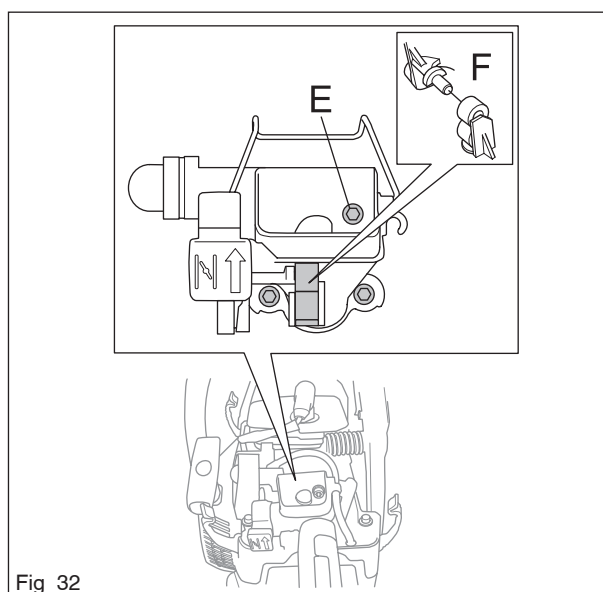

Fig 32

6. Disassemble the pump cover (G) over the measuring chamber cover (R) and carefully remove the control diaphragm (H) with gasket (J).
7. Unscrew the screw (K) and remove the needle valve (L) with lever (M), shaft (N) and spring (P).
8. Unscrew the screw (Q) above the pump unit and carefully remove the gasket (S) and diaphragm (T).
9. Use a needle or similar device and carefully pull up the fuel screen (U).
10. Unscrew the high (V) and low jet screws (W) (see figure 34).
11. If necessary, dismount the throttle valve (X), choke valve (Z) and air shutter (Y) and remove the shafts with levers and springs (see figure 34).

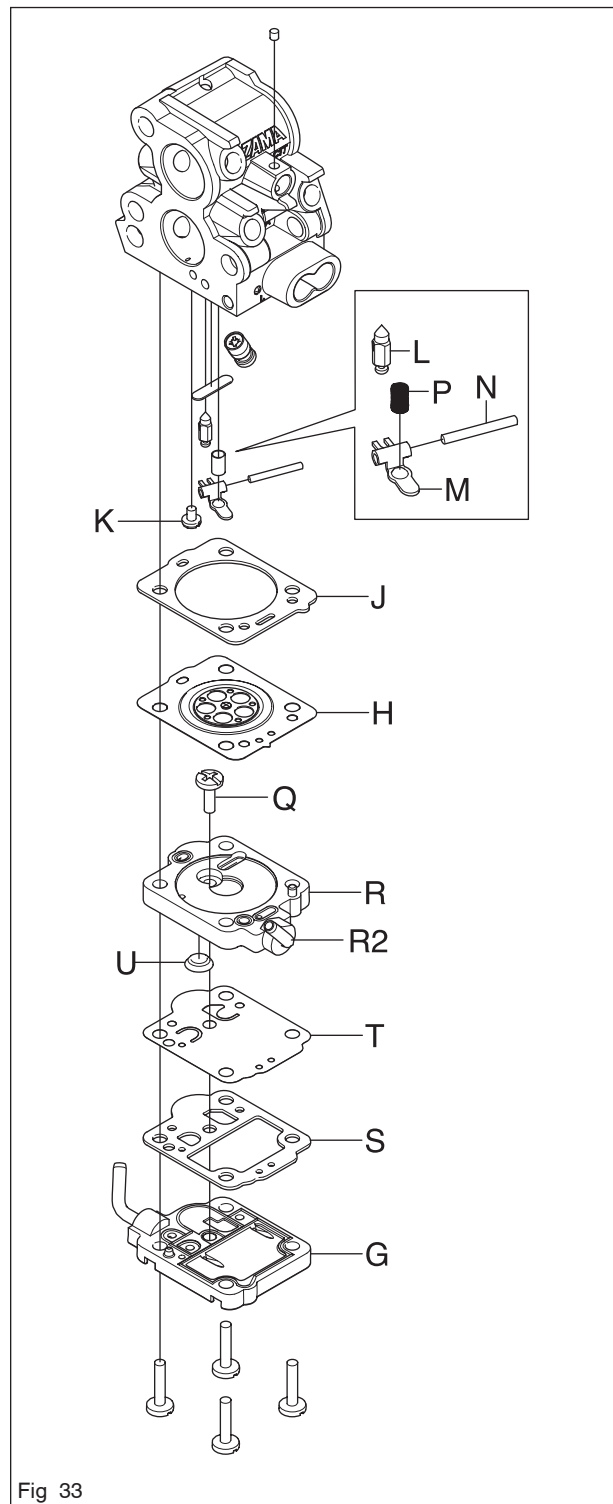

Fig 33

Cleaning and inspection

Clean all units in clean petrol.

Use compressed air to dry the petrol on the components. Direct the air through all channels in the carburettor housing and ensure that they are not blocked. Check the following:

1. That gaskets, pump and control diaphragms are undamaged.
2. That there is no play on the throttle and choke valve shafts.
3. That the needle valve (L) and its lever (M) are not worn (see figure 33).
4. That the fuel screen (U) is whole and clean (see figure 33).
5. That the tips of the high (V) and low jet screws (W) are not damaged (see figure 34).
6. That the intake manifold (R2) is undamaged (see figure 33).
7. The carburettor has an extra air shutter connected in parallel with the ordinary throttle valve.

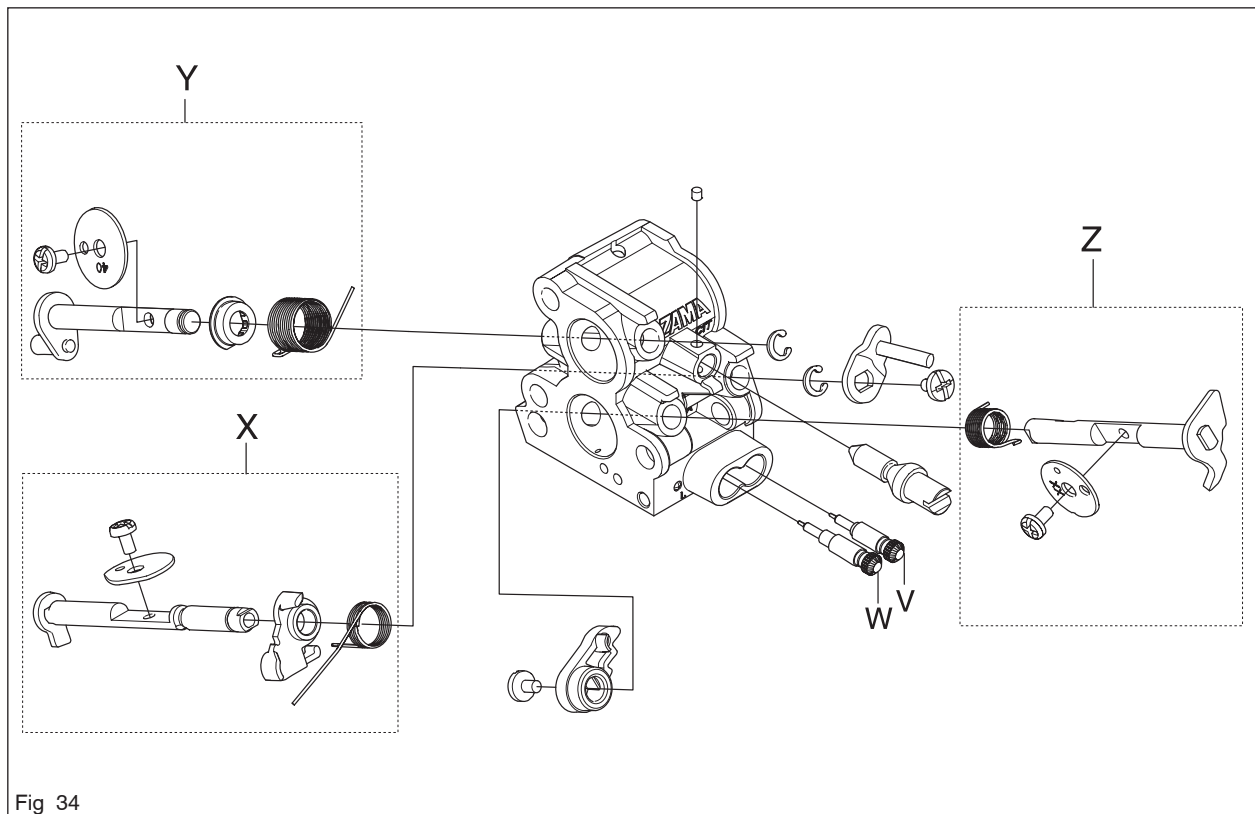

Fig 34

Assembly

Maintain a high level of cleanliness when assembling the carburettor. The slightest contamination can result in running problems.

1. If the throttle and choke valves, together with levers and springs were removed, they should be refitted. The spring is tensioned 1-2 turns. Lubricate the shaft bearings with light oil.
2. Fit the high (V) and low (W) speed needles and springs. Note! Do not fully tighten the screws. This will damage the seats and needle tips.
3. Fit the fuel filter (U) by using the handle of a small screwdriver. (see figure 33)
4. Fit pump cover (G), gasket (S) and measuring chamber cover (R) over the pump unit (see figure 33).
5. Fit the needle valve (L) with lever (M), shaft (N) and spring (P) and tighten the screw (K). Fit the expansion washer (F) (see figure 35).
6. Check using a ruler or the like that the lever is level with the assembly plane on the cover. The lever arm can be bent if necessary (see figure 36).

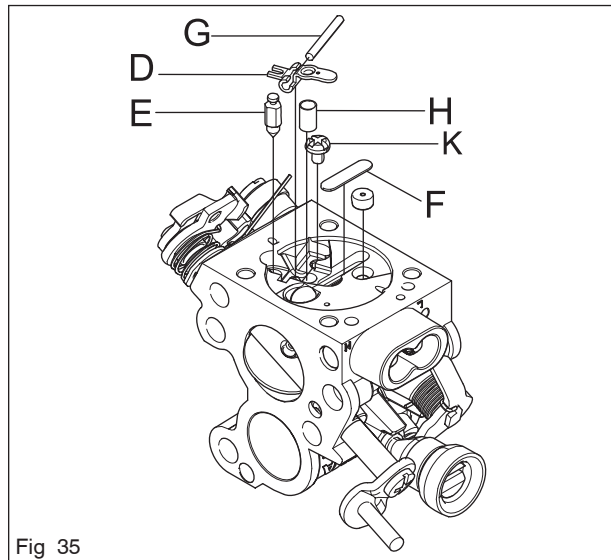

Fig 35

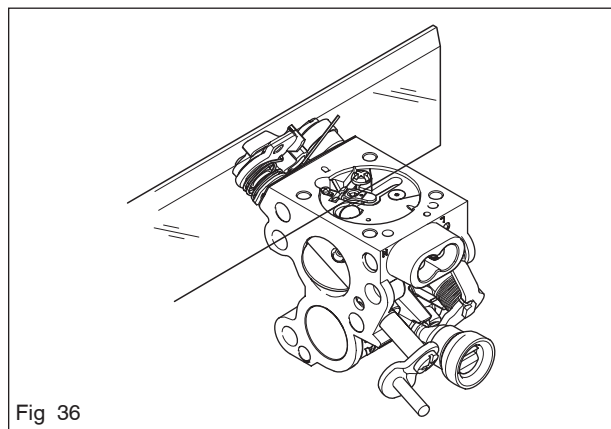

Fig 36

7. Fit the control diaphragm (T) with gasket (S) and measuring chamber cover (R) over the metering unit (see figure 37).
8. Press in the screen (U). Fit the measuring chamber cover (R) and tighten the screw (Q) (see figure 37).
9. Put together the gasket (J) and control diaphragm (H) and press up (see figure 37).
10. Assemble all the parts and tighten the four screws (see figure 37).
- 11.. Carry out a pressure test.

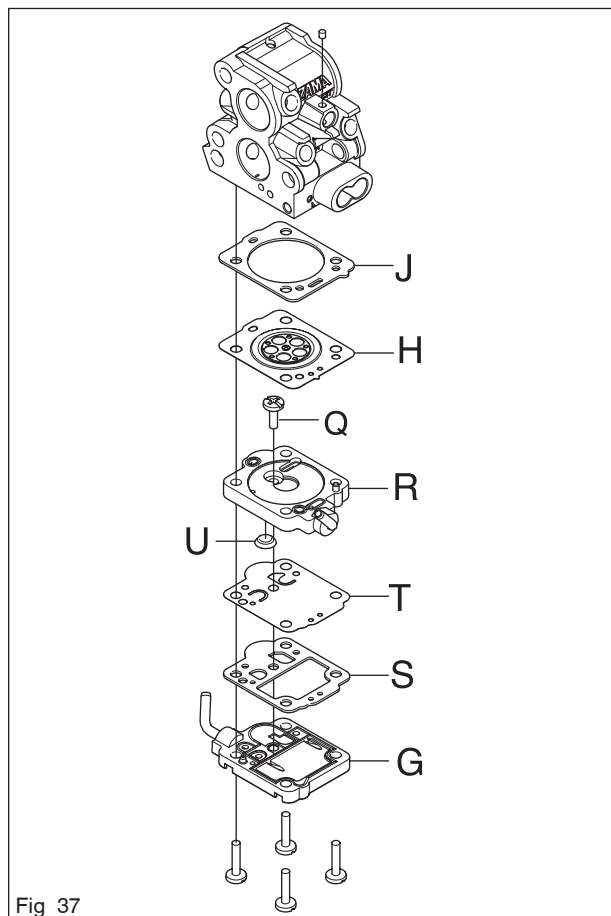

Fig 37

Pressure testing the carburettor

Pressure testing should be carried out with the carburettor fully assembled. Testing should always be carried out after the carburettor has been repaired, but it can also be carried out as trouble shooting before dismantling the carburettor.

See figure and carry out the test as follows:

- 1**
Set the high and low jet screws two turns from the bottom.
- 2**
Connect pressure tester to the carburettor's fuel intake.
- 3**
Lower the carburettor into a beaker of water (see figure 37).
- 4**
Pump the pressure up to 50 kPa.
- 5**
No leakage is permitted. If a leakage occurs refer to the table below.

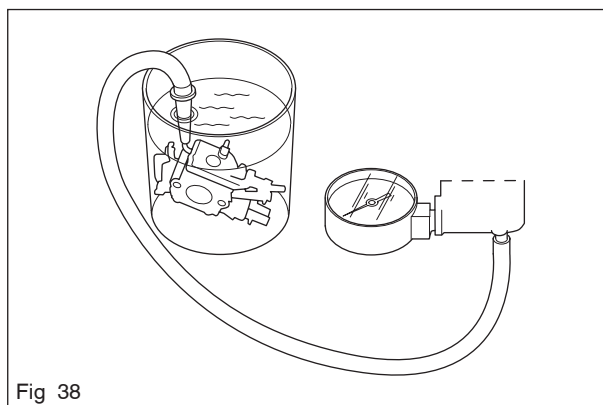

Fig 38

Leakage at	Fault with
Diffuser jets Leakage in impulse tube Ventilation hole on metering unit.	Needle valve Pump diaphragm Control diaphragm

Assemble on the saw

1. Press the carburettor down towards the partition wall. Make sure that it gets into the correct position.
2. Fit the filter holder by hooking the choke control into the choke lever (A).
3. Hook on the rubber mountings. Insert and tighten the screws.

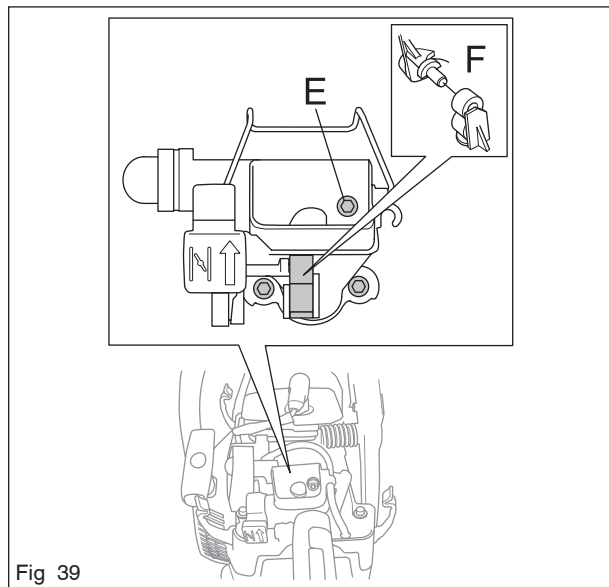

Fig 39

4. Insert the return hose (B) into its position in the filter holder.
5. Press on the fuel diaphragm (D). Fit the suction hose (C) and return hose (B).

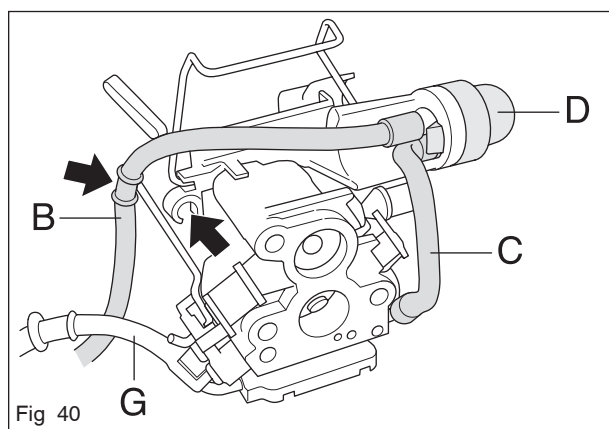

Fig 40

6. Hook in the throttle actuator rod into the carburettor. Thread the handle holder into the throttle actuator rod (A). Push the rod forwards so that it can be inserted into the handle part.
7. Push down the handle holder into the filter holder (see figure 42).

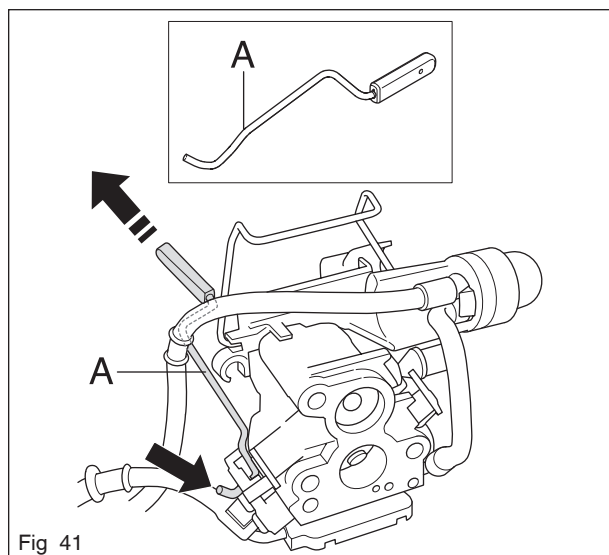

Fig 41

8. Assemble the air filter and cylinder cover.
9. Mount the handle holder.

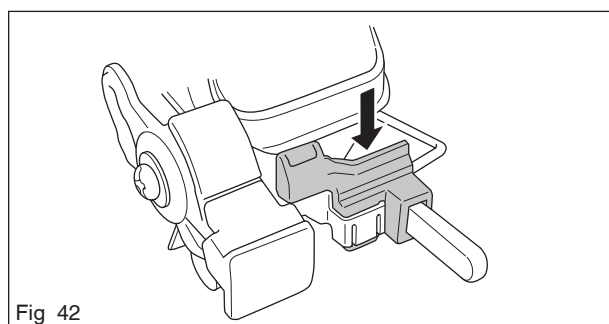

Fig 42

Carburettor adjustment

Conditions during adjustment

- The air filter should be clean and the cylinder cover fitted when adjustments are made. Adjusting the carburettor with a dirty air filter will give a too lean fuel mixture the next time the air filter is cleaned. This can result in serious damage to the engine.
- Mount, for this model, approved bar and chain combination (see Technical data in the Operator's Manual).
 - 435/e II 16"
 - 440/e II/TB 16"
- The chain should not be tensioned more than that it remains ~ 0,2 inches to the bar.

(See figure 43)

Replacement of the H-needle or complete carburettor

1. Carefully screw the new H-needle to the bottom and turn it anticlockwise "A" turns.
2. Start the engine. If necessary, adjust the idling speed with the T-screw until the chain stops.
3. Adjust the H-needle to give a top speed of "B" rpm. Use a tachometer.

435/e II A = 2
440/e II/TB A = 2

435/e II B = 12 500 -13 000, speed limitation
440/e II/TB B = 12 500 -13 000, speed limitation

Use screwdriver 530 03 55-60.

4. Let the engine run at "B" rpm ~ 1 minute, until warm.

Replacement of the L-needle

1. Screw the new L-needle to the bottom and then turn it counterclockwise "D" turns.

435/e II D = 2,5
440/e II/TB D = 2,5

(See figure 44)

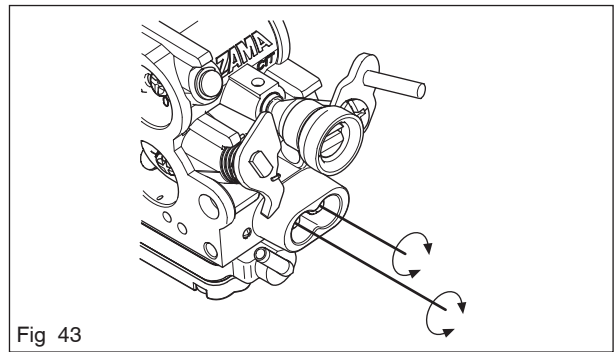

Fig 43

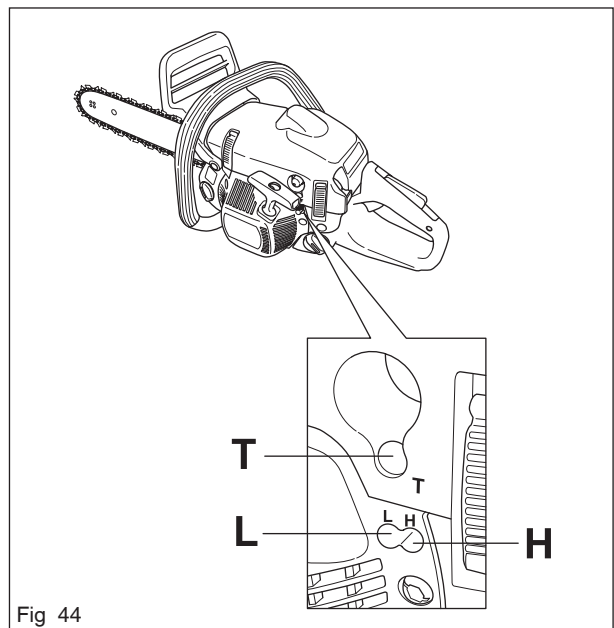

Fig 44

7.16 Tank unit



WARNING!

The fuel used in the chain saw has the following hazardous properties:

1. The fluid and its vapour are poisonous.
2. Can cause skin irritation.
3. Is highly inflammable.

Dismantling

1. Drain the fuel from the tank.
2. Dismantle the cylinder cover, bar and chain. See the Operator's Manual.
3. Unhook the throttle actuator rod (G) from the carburettor (see figure 45).
4. Dismantle the fuel hose (B) and the fuel pump return hose (D) (see figure 45).
5. Remove the screws. (A). Loosen the handle (see figure 46).
6. Dismantle the fuel tank.

NOTE!

Exercise care so that the fuel hose and throttle cable are not damaged.

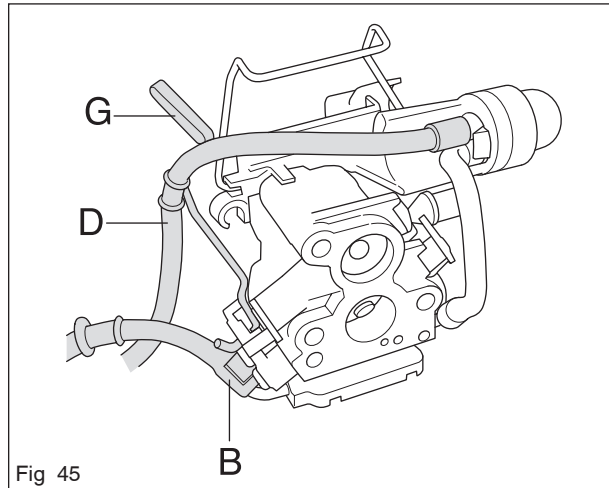

Fig 45

7.17 Venting the fuel tank

The two-way valve (C) has the following properties (see figure 47):

- Controlled opening pressure in both directions, which prevents a positive pressure or a vacuum developing in the fuel tank and impairing engine performance. This also prevents fuel leakage.
- Opening pressure outward 100–450 mbar.
- Opening pressure inward (vacuum) max. 70 mbar. (2 positions)

Test

Opening pressure outward:

1. Open the filler cap and let the cap remain open during the entire test. Drain the fuel from the tank.
2. Connect the pump, ref. no. 531 03 06-23, to the tank valve. (C)
3. Switch the pump to vacuum mode.
4. After pumping the indicator should be between 10–45 kPa.

Opening pressure inward:

1. Open the filler cap and let the cap remain open during the entire test. Drain the fuel from the tank.
2. Connect the pump, ref. no. 531 03 06-23, to the tank valve. (C)
3. Switch the pump to pressure mode.
4. After pumping the indicator should stop at max. 7 kPa.

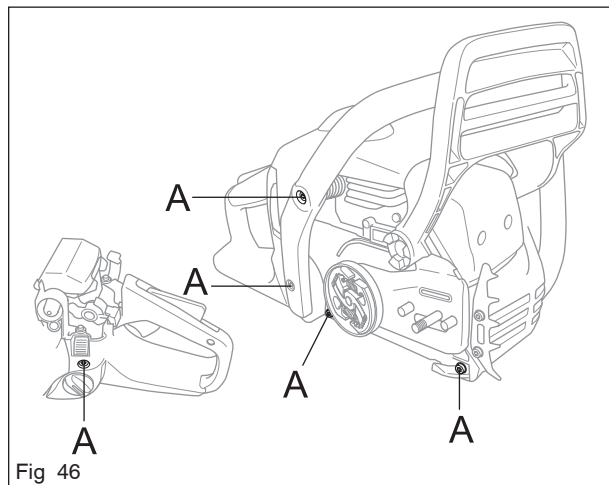

Fig 46

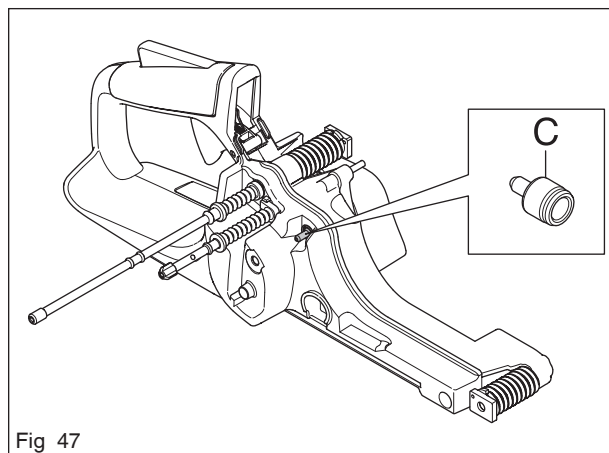

Fig 47

Assembly

1. If the throttle lock has been removed, this must be assembled before the tank unit and engine unit are assembled.
2. Lift the engine unit above the tank unit and insert the fuel hose (in J), return hose (in H) in the bottom of the carburettor compartment (see figure 48).
3. Fit the handle with the screws (A). Tighten the screws with the torque set out in the service data (see figure 46).
4. Fit the fuel hose (B) and fuel pump return hose (D) on the carburettor (see figure 45).
5. Mount the throttle actuator rod (see figure 45).
6. Assemble the cylinder cover, bar and chain. See the Operator's Manual.

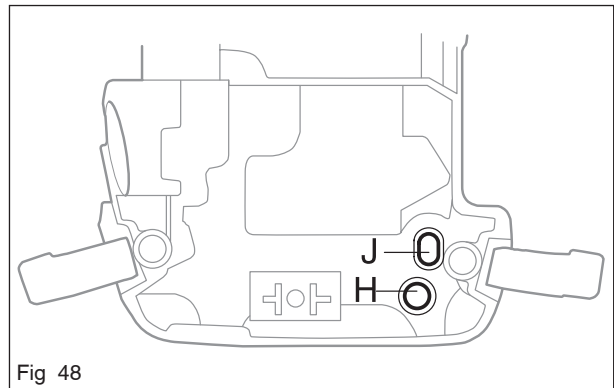

Fig 48

7.18 Vibration damping system**Dismantling**

1. Dismantle the following parts:
 - Bar and chain.
 - Cylinder cover
 - Tank unit and handle.
2. Dismantle the spring on the cylinder with the help of a 5 mm allen key (see figure 49).
3. Dismantle the springs on the tank unit with the help of a 5 mm allen key (tool 502 50 18-01) (see figure 50).

Cleaning and inspection

Clean and inspect all parts.

Assembly

1. Assemble the springs on the cylinder with the help of a 5 mm allen key (tool 502 50 18-01).
 Note! Springs with a greater resistance are available, but should only be used together with a longer bar. See illustrated part list for spare part number.
2. Assemble the following parts:
 - Tank unit and handle.
 - Cylinder cover.
 - Bar and chain.

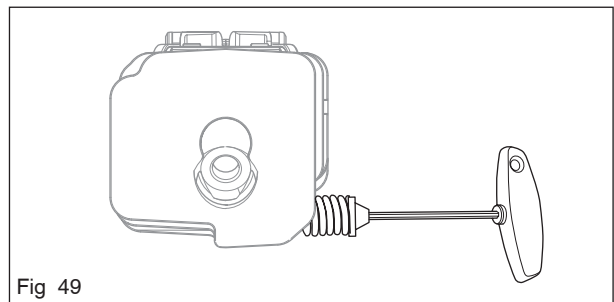

Fig 49

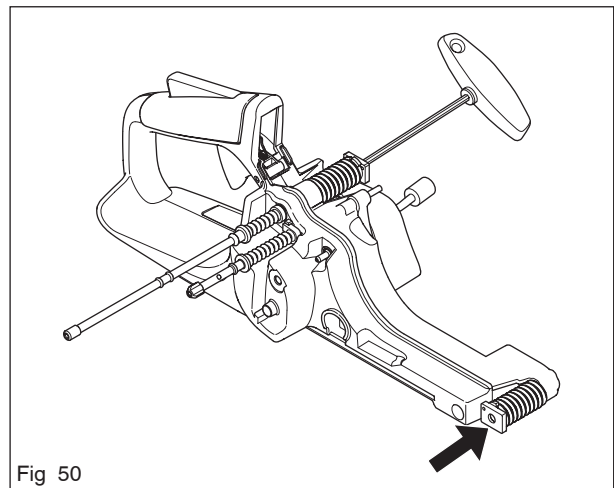

Fig 50

7.19 Replacing the fuel filter

NOTE!

Do not use knurled pliers to disconnect or reconnect the fuel hose. This could damage the hose and lead to leakage or fracture.

- 1
First remove the old fuel filter from the tank unit using special tool 502 50 83-01.
- 2
Pull the fuel hose (B) out of the tank unit and pull off the filter.
- 3
Fit the new fuel filter (A) and feed the fuel hose back into position.

7.20 Replacing the fuel hose/ return hose

The fuel hose is moulded and can only be removed from outside of the fuel tank.

Use suitable pliers with a plain cutting face and loosen the hose (B) (see figure 45) from the fuel tank. Align the cut-out against the plastic pin when assembling. Replace the return hose when required.

7.21 Replacing the air-purge

Dismantling

1. Dismantle the cylinder cover and the air filter.
2. Loosen the suction hose (C) and return hose from the fuel pump (see figure 31).
3. Unsnap the fuel pump from the filter holder.

Assembling

1. Fit the return hose on the fuel pump.
2. Snap the purge into the filter holder (see figure 51).
4. Assemble the air filter and cylinder cover.

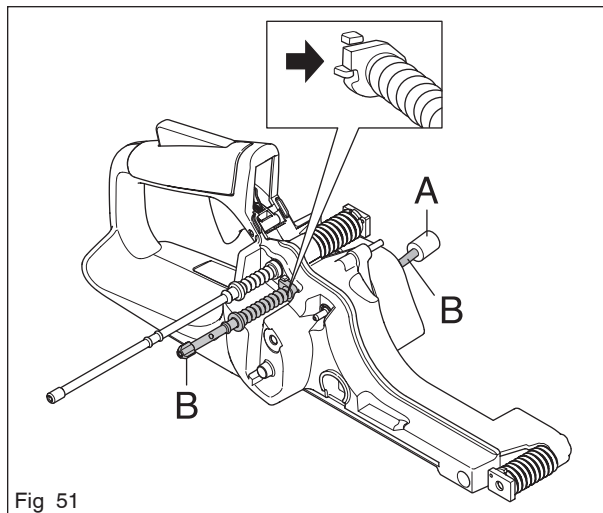

Fig 51

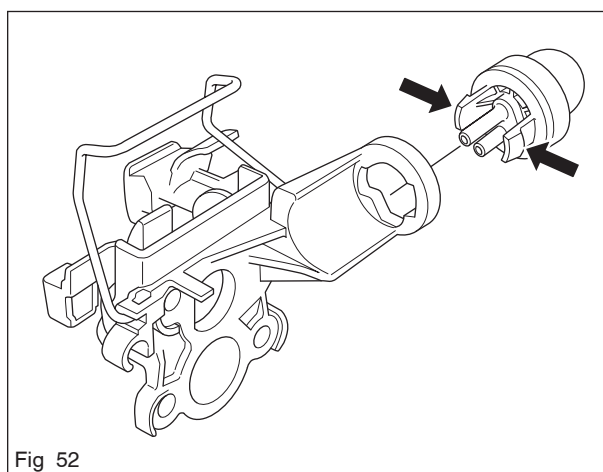

Fig 52

7.22 Piston and cylinder – removal

1

Remove:

- cylinder cover
- carburettor (see “Carburettor – removal”)
- silencer
- spark plug
- fuel unit

2

Undo the four cylinder bolts from the underside and lift the cylinder off carefully (see figure 52).

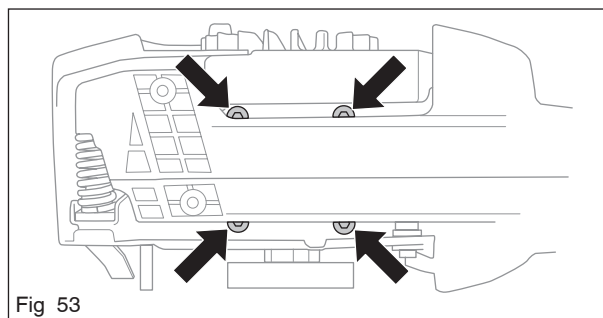

Fig 53

3

Cover the opening in the crankcase (see figure 54).

4

Remove the circlips from the ends of the gudgeon pin and press it out. Then lift off the piston (see figure 53 and 54).

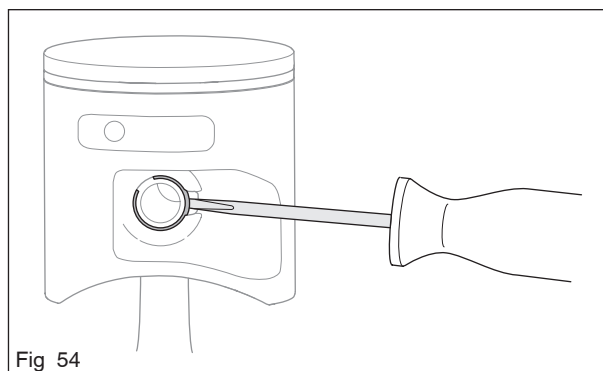

Fig 54

5

Remove the little end bearing (see figure 54).

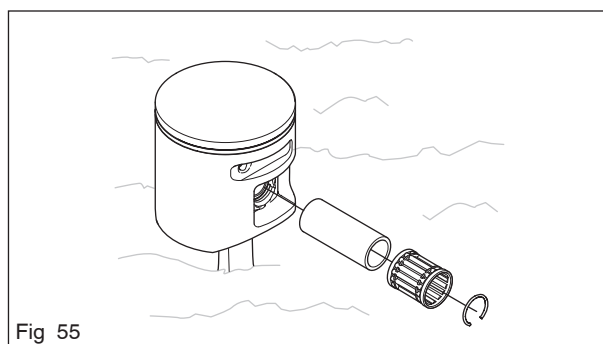

Fig 55

If replacing the cylinder:

Remove the intake manifold, see “Air intake system – removal”.

Cleaning and inspection

Clean all the components, scraping off all traces of old gasket and carbon from the following places:

- Piston crown
- Top of the cylinder bore
- Cylinder exhaust port
- Decompression valve channel
- Cylinder base and/or crankcase

(see figure 56)

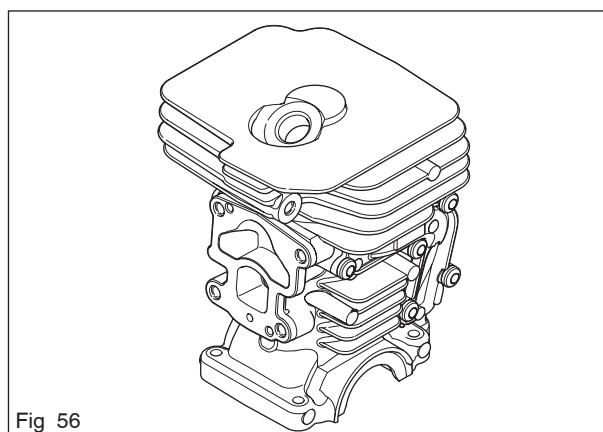
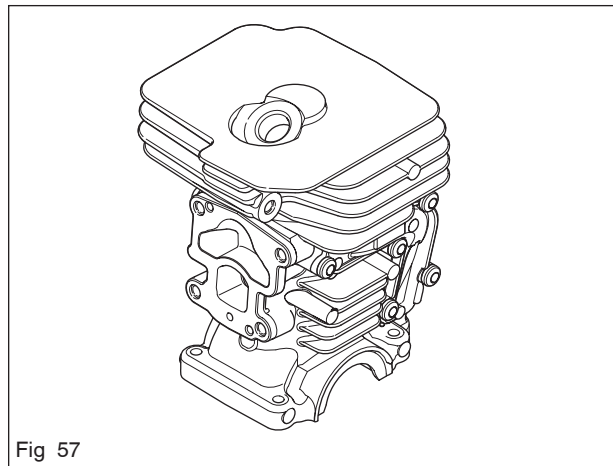

Fig 56

Check the following:

- The surface coating of the cylinder is not worn through, especially in the upper part of the cylinder.
- The cylinder is free from score marks and areas of wear.
- The piston is free from score marks. Small scratches can be polished out with fine emery paper.
- The piston ring is freely moving in its groove.

(see figure 57)



- Measure piston ring wear. This should not exceed 1 mm (see figure 58). Use the piston to push the piston ring for correct alignment.
- The needle roller bearing is undamaged.
- The intake manifold is undamaged.
- That the air hoses and impulse hose are undamaged.
- Pressure test the decompression valve.

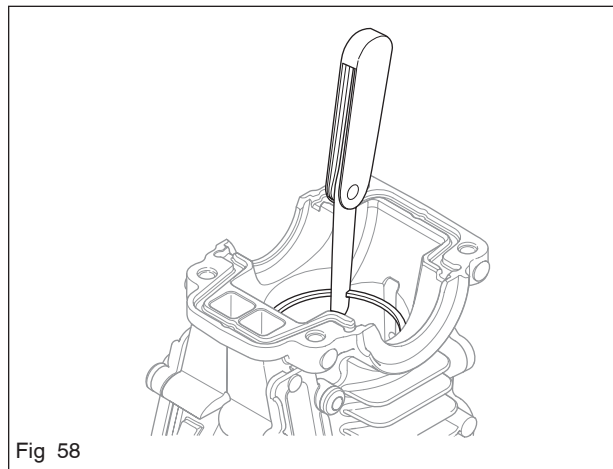

Faults and causes**Score marks on the piston (A)**

1. Incorrect carburettor setting. Too high over-speed.
2. Too low octane fuel.
3. Too low or incorrect oil in the fuel.

Carbon build-up (B)

1. Incorrect carburettor setting. Too low over-speed.
2. Too much or incorrect oil in the fuel.

Piston ring breakage

1. Excessive engine speed.
2. Piston ring worn out.
3. Oversized piston ring groove.

(See figure 59)

7.23 Piston and cylinder – refitting

1

Lubricate the little end bearing with two-stroke oil and insert it in the connecting rod (see figure 60).

2

Fit the piston with the arrow pointing towards the exhaust port. Push the gudgeon pin in and fit the circlips. **NOTE!** Use new wire fuses (see figure 60).

3

Fit the intake manifold on the cylinder, with insulating plate (4 screws).

4

Lubricate the piston ring and piston with two-stroke oil.

5

Fit new cylinder base gaskets. Lower the cylinder over the piston carefully.

6

Fit the cylinder bolts, tightening them in diagonal pairs to a torque of 8,5–9,5 Nm.

NOTE!

It is very important that there are no leaks in the inlet system, otherwise the engine may seize.

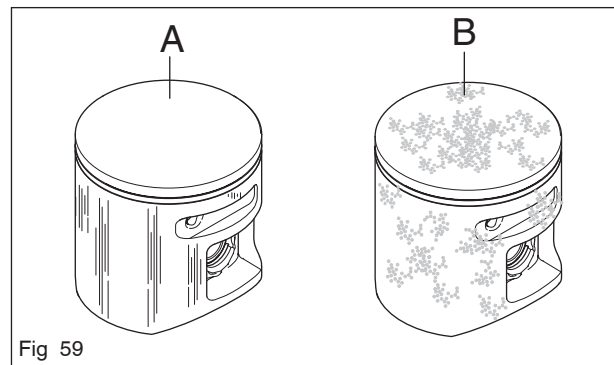

Fig 59

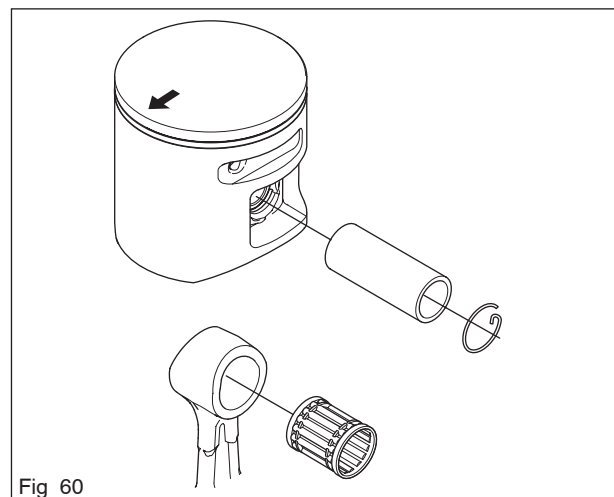

Fig 60

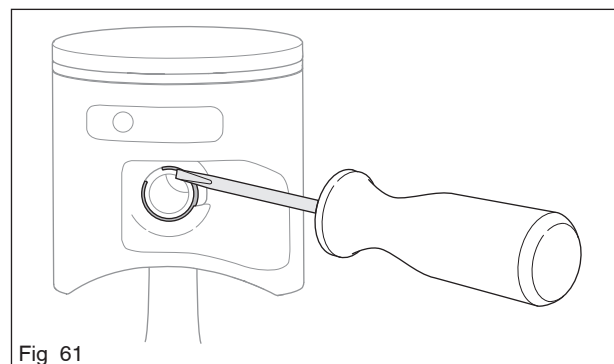

Fig 61

Inlet manifold

The intake system has two intakes.

1. The lower intake leads the fuel and air mixture from the carburettor to the cylinder.
2. The upper intake leads air to the cylinder.

Assembling the intake system

1

Mount the intake manifold (A) and the partition walls (B and C) on the cylinder using tools 502 50 87-01 (see figure 62).

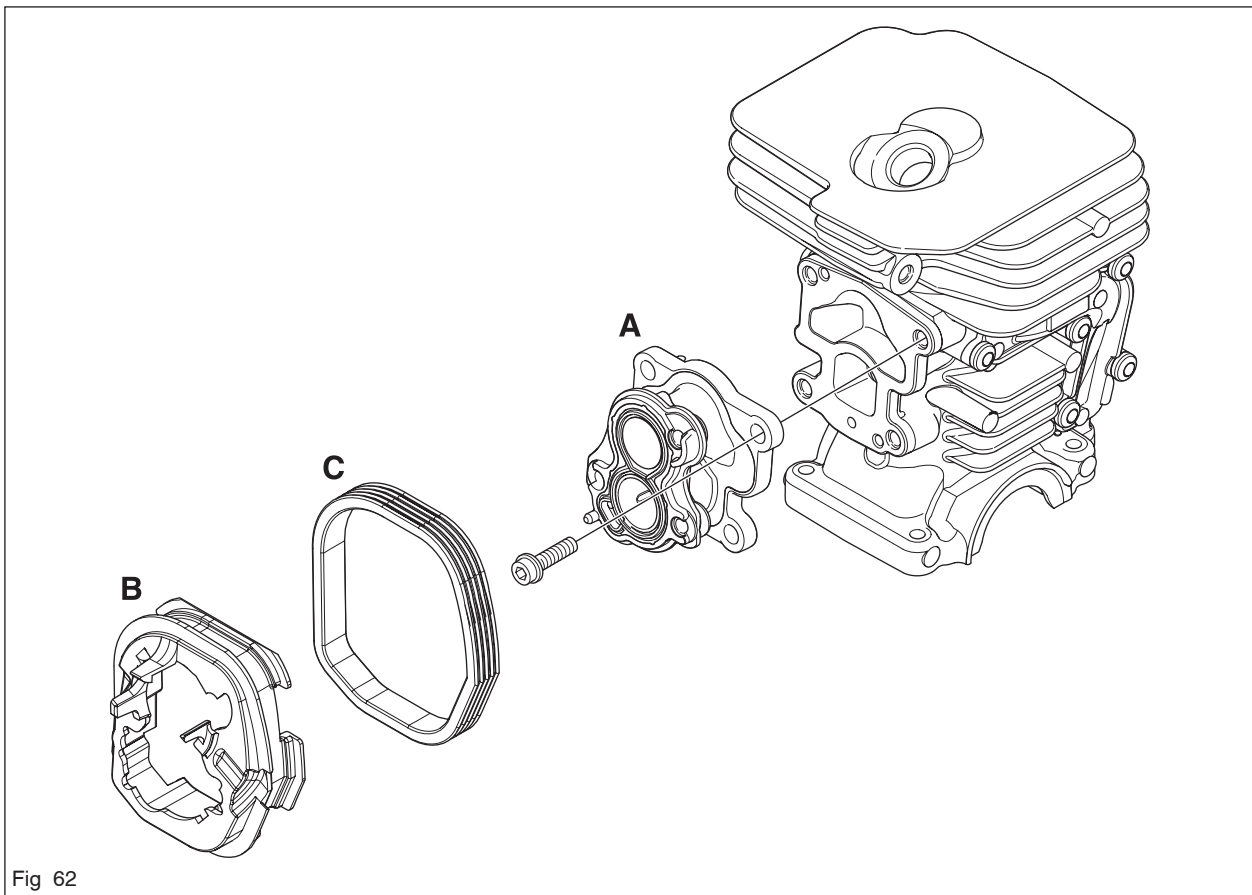

7.24 Cylinder – pressure testing

1

Remove:

- cylinder cover
- carburettor
- spark plug

2

Mount cover plate 504 63 93-01 (see figure 63).

3

Loosen the screws on the muffler and press the rubber sheet 502 54 11-02 between the muffler and cylinder. Tighten the top two muffler screws (see figure 64).

4

Fit the pressure testing spark plug 503 84 40-02 and connect the pressure testing tool 531 03 06-23 (see figure 64).

5

Pump the pressure up to 80 kPa (0.8 bar). Wait 30 seconds. The pressure should not be less than 60 kPa (0.6 bar). Remove the cover plates from the silencer and carburettor, tighten the bolts to the specified torque. Remove the pressure test nipple 503 84 40-02 and refit the spark plug.



WARNING!

After pressure testing the cylinder, check that the inlet manifold is seated correctly, otherwise the saw may be damaged.

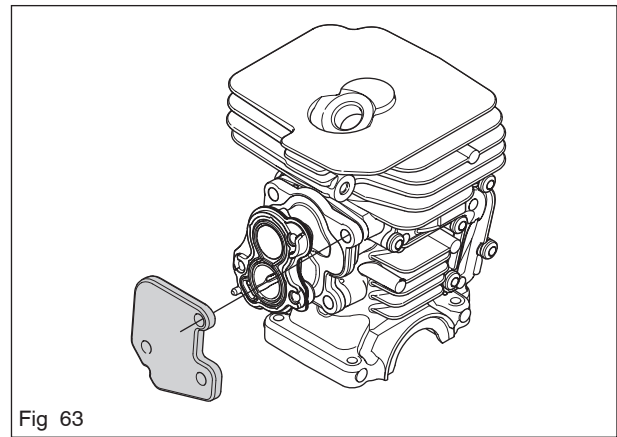

Fig 63

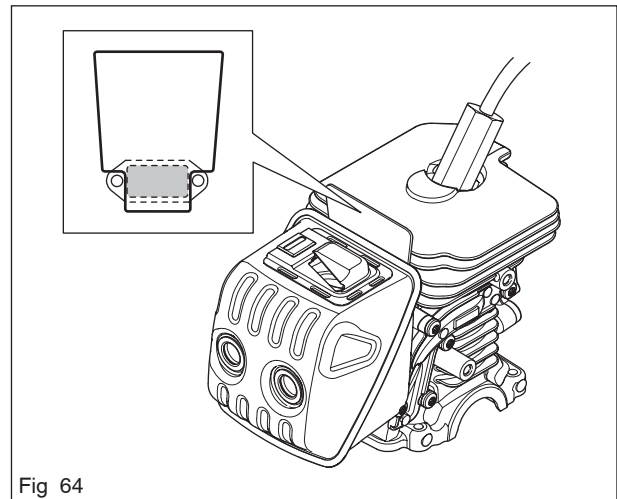

Fig 64

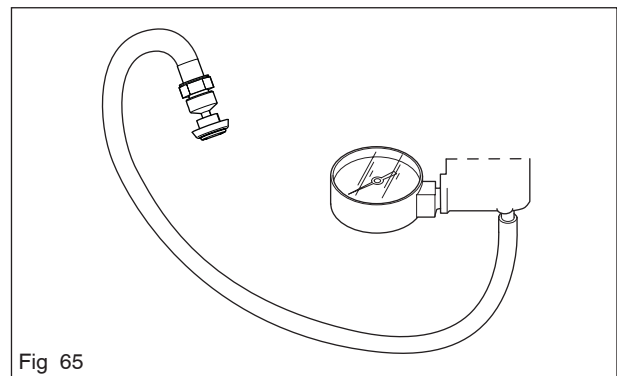

Fig 65

7.25 Crankshaft complete - dismantling

1

Remove the following:

- chain and bar
- clutch cover
- cylinder cover
- starter assembly*
- centrifugal clutch*
- carburettor*
- silencer*
- handle system
- hand guard
- piston and cylinder*

* See special instructions.

2

Lift the crankshaft completely out of the crankcase (see figure 66).

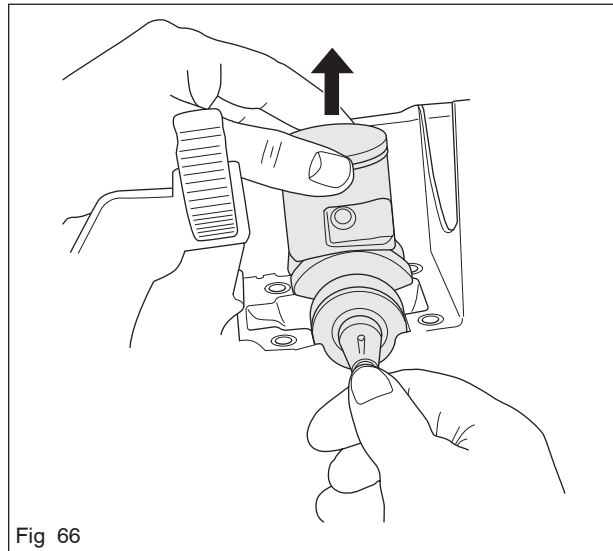

Fig 66

7.26 Crankshaft bearings – replacement

Remove:

- The crankshaft complete from the crankcase.

1

Pull the crankshaft bearing off of the crankshaft using a bearing puller (see figure 67).

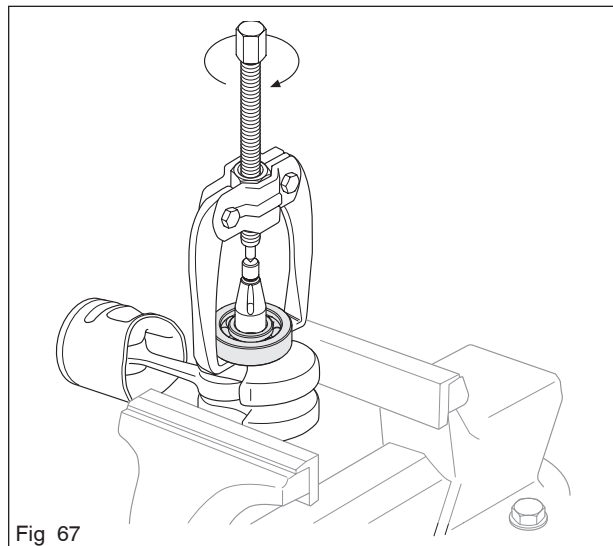

Fig 67

2

Place a new bearing on the shaft and push into position using tool 502 50 30-18 (see figure 68).

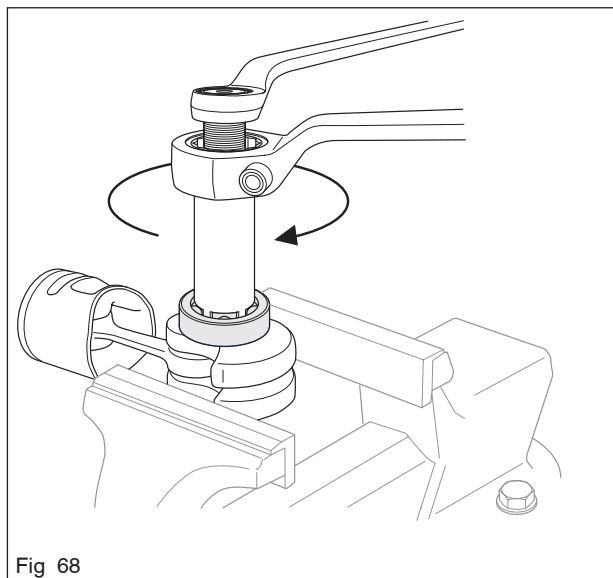

Fig 68

7.27 Crankshaft complete – reassembly

1

Fit the crankshaft complete in the crankcase.

Refit the following parts:

- piston and cylinder*
- handle system
- hand guard
- silencer*
- carburettor*
- centrifugal clutch*
- starter assembly*
- cylinder cover
- clutch cover
- chain and bar

* See special instructions.

7.28 Repairing damaged threads

A repair kit, 503 27 33-01, is available for repairing damaged threads.

First drill out the hole using:

6,1 mm drill bit for plastic crankcase

Then screw in the thread insert using a suitable bolt and spanner.

This type of thread insert is best suited for use in plastic and magnesium, but not for repairing threads in aluminium. In that case use a helicoil insert with metric screw (see figure 69).

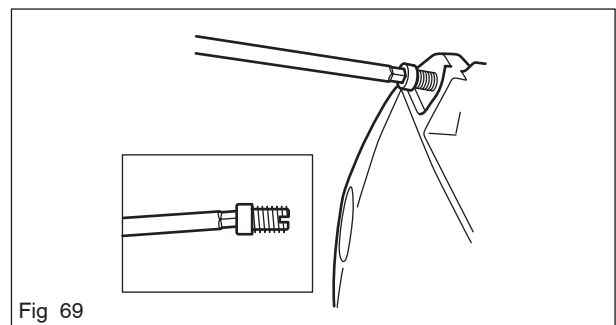

Fig 69

7.29 Replacing the bar bolt

Replacing the front bar guide.

- 1
Drain the oil tank.
- 2
Knock through the old guide bar bolt so that it falls into the oil tank.
- 3
Remove the bolt from the oil tank.
- 4
Secure steel wire to the outer part of the bar bolt (A), thread the steel wire through the oil tank and out through the bolt hole in the crankcase (see figure 70).
- 5
Pull the steel wire so the bolt comes out of its hole (see figure 71).
- 6
Check that the bolt's square head fits in the washer (D) which is positioned in the cut-out in the crankcase.
- 7
Pull out the bar bolt with its nut. Place a spacer between the nut and crankcase (see figure 71).
- 8
Refill with chain oil.

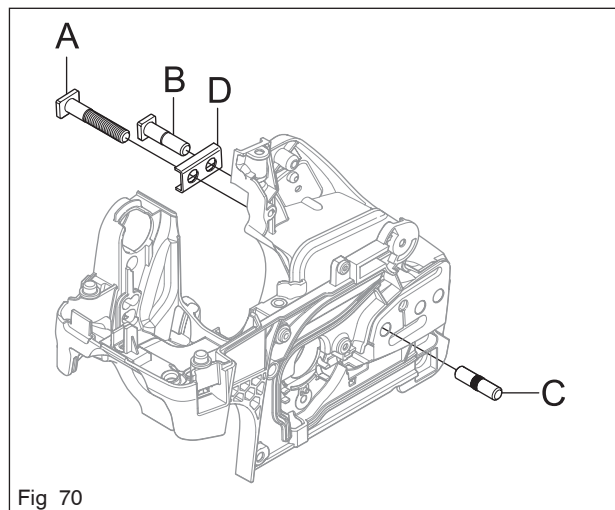

Fig 70

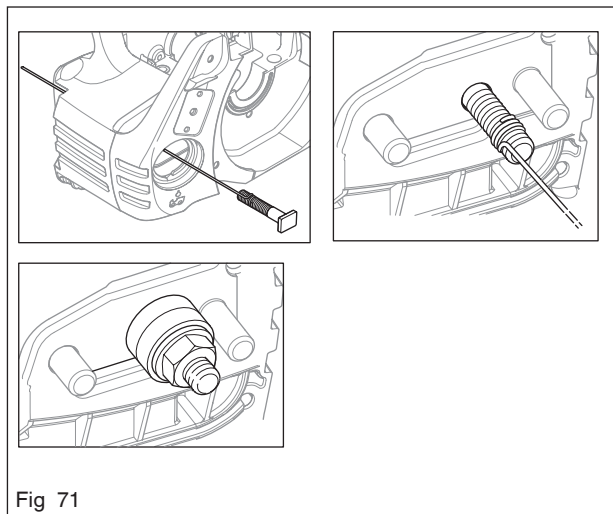

Fig 71

Replacing the rear bar guide

- 1
Pull out the bar guide (C) with the help of slip-joint pliers (see figure 70).
- 2
Fit the bar guide with the help of a hammer.

8 Troubleshooting

Contents

8.1	Troubleshooting	54
8.2	Troubleshooting methods	55

8.1 Troubleshooting

The various faults that can affect a chainsaw are divided into four groups. In each group the likely symptoms are given on the left and possible causes are listed on the right. The most likely faults are given first, and so on.

Starting

Difficulty starting	Adjust L screw Air filter blocked Choke not working Worn choke pivot Worn choke valve Fuel filter blocked Fuel line blocked Piston ring seized Blocked impulse channel
Carburettor leaking fuel	Loose or faulty fuel pipe Hole in diaphragm Worn needle valve Needle valve assembly sticking Needle valve set too high Leak in metering system (air or fuel) Loose cover on carburettor pump side
Flooding when engine not running	Worn needle valve Needle valve set too high Needle valve assembly sticking

Idling (low rpm)

Will not idle	Adjust L screw Leaking air intake hose (rubber) Loose carburettor mounting bolts Loose or faulty fuel hose Fuel filter blocked Fuel line blocked Fuel tank vent blocked Throttle valve pivot stiff Throttle pushrod sticking Defective throttle return spring Bent throttle stop Faulty diffuser jet
Idling too rich	Adjust L screw Worn needle valve Needle valve set too high Worn needle valve lever Leaking control diaphragm/cover plate Needle valve assembly sticking

Idling (low rpm) (cont.)

Idles when L screw closed	Worn needle valve Leaking control diaphragm/cover plate Needle valve assembly sticking Worn needle valve lever Faulty diffuser jet
Idling uneven	Fuel filter blocked Fuel line blocked Leaking air intake hose (rubber) Loose carburettor mounting bolts Worn throttle valve pivot Loose throttle valve screw Worn throttle valve Needle valve assembly sticking Leak in metering system (air or fuel) Metering system centre knob is worn Hole in diaphragm Leaking control diaphragm/cover plate Crankcase leaking
L screw requires constant adjustment	Fuel line blocked Needle valve set too high Needle valve assembly sticking Leak in metering system (air or fuel) Leaking control diaphragm/cover plate Faulty diffuser jets Crankcase leaking
Too much fuel at idling	Needle valve set too high Needle valve assembly sticking Metering system damaged Worn needle valve Leaking control diaphragm/cover plate Metering system incorrectly assembled

High rpm

Will not run at full throttle	Adjust H screw Blocked air filter Blocked fuel tank vent Blocked fuel filter Fuel line blocked Loose or damaged fuel hose Impulse channel leaking Impulse channel blocked Loose cover on carburettor pump side Faulty pump diaphragm Leaking air intake hose (rubber) Loose carburettor mounting bolts Needle valve set too low Metering system damaged Metering system incorrectly assembled Leaking control diaphragm/cover plate Needle valve assembly sticking Blocked silencer
Low power	Adjust H screw Blocked fuel tank vent Blocked fuel filter Impulse channel leaking Impulse channel blocked Loose cover on carburettor pump side Faulty pump diaphragm Blocked air filter Needle valve assembly sticking Leak in metering system (air or fuel) Metering system incorrectly assembled Loose diaphragm rivet Hole in diaphragm Leaking control diaphragm/cover plate
Will not "four-stroke"	Blocked fuel tank vent Blocked fuel filter Fuel line blocked Loose or damaged fuel hose Impulse channel leaking Impulse channel blocked Loose cover on carburettor pump side Faulty pump diaphragm Leaking air intake hose (rubber) Loose carburettor mounting bolts Needle valve set too low Leak in metering system (air or fuel) Metering unit incorrectly assembled Loose diaphragm rivet Hole in diaphragm Leaking control diaphragm/cover plate

Acceleration och retardation

Does not accelerate	Adjust L screw Adjust H screw Blocked air filter Blocked fuel tank vent Blocked fuel filter Fuel line blocked Loose or damaged fuel hose Impulse channel blocked Loose cover on carburettor pump side Faulty pump diaphragm Leaking air intake hose (rubber) Loose carburettor mounting bolts Needle valve set too low Metering system incorrectly assembled Needle valve assembly sticking Faulty diffuser jets Blocked silencer
Engine stalls when throttle released	Adjust L screw Adjust H screw Faulty pump diaphragm Needle valve set too high Needle valve assembly sticking Faulty diffuser jets
Over rich acceleration	Adjust L screw Adjust H screw Blocked air filter Faulty pump diaphragm Faulty diffuser jets

8.2 Troubleshooting methods

In addition to the faults described in the above table, trouble shooting can be carried out on specific components or sub-systems of the chainsaw. The various procedures are described in the relevant chapters, see the contents page, as follows:

- Checking the operation of the chain brake
- Measuring the resistance of the stop plate
- Pressure testing the carburettor
- Pressure testing the decompression valve
- Pressure testing the cylinder



www.husqvarna.com

115 57 76-26

2013W10