

Workshop Manual
525P4S 525P5S 525PT5S

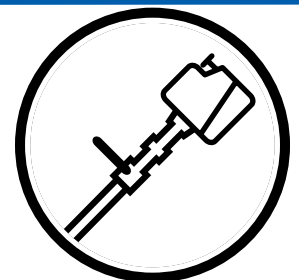

English

Workshop Manual

Contents

Index	4
Introduction and safety instructions	6
Technical data.....	10
Engine special tools	12
Service data	15
Safety equipment	24
Repair instructions.....	28
Troubleshooting	78

Husqvarna AB has a policy of continuous product development and therefore reserves the right to modify the design and appearance of products without prior notice.

A

Air filter, dismantling and assembling 36

C

Carburetor 37
Carburetor, dismantling 39
Carburetor, assembling 42
Carburetor, settings 44
Centrifugal clutch, dismantling..... 46
Centrifugal clutch, assembling..... 48
Clutch drum, replacing..... 62
Clutch drum, dismantling and assembling..... 62
Crankshaft, dismantling 59
Crankcase, dismantling 59
Crankshaft, assembling 61
Crankcase, assembling 61
 Cylinder and piston, dismantling 49
 Cleaning and inspection 51
 Analysis and actions..... 51
Cylinder and piston, assembling..... 58

F

Flywheel, dismantling 46
Flywheel, assembling 48
Fuel system 36
Fuel filter..... 37
Fuel pump, air purge 37

I

Introduction and safety instructions 7
Ignition module, adjusting..... 35
Ignition module, dismantling 46
Ignition module, assembling 48
Ignition spark, checking 32

M

Muffler, dismantling..... 25
Muffler, Assembling 25

P

Piston, dismantling 49
Piston, assembling 58

S

Saw head, dismantling (PT5S) 65
Saw head, assembling (PT5S) 67
Saw head, dismantling (P4S and P5S) 74
Saw head, assembling (P4S and P5S)..... 77
Service data 15
Shaft, dismantling (P4S and P5S) 73
Shaft, assembling (P4S and P5S) 77
Special tools 12
Starter recoil pulley, dismantling 29
Starter recoil pulley, assembling 29
Start pawls, replacing 31
Stop switch, dismantling 25
Stop switch, assembling 25
Stop switch, resistance test 26
Symbols in the Workshop Manual 9
Symbols on the machine 9

T

Tank Venting 36
Technical data..... 10
Telescopic tube, dismantling (PT5S) 69
Telescopic tube, assembling (PT5S) 70
Throttle, dismantling 26
Throttle, assembling 27
Troubleshooting 78
 Engine does not start 79
 Engine is difficult to stop..... 80
 Engine stops working during operation 80
 Insufficient output or unstable rotation..... 81
 Other Engine problems..... 82

2 Introduction and safety instructions

Contents

2.1	General	7
2.2	Safety	7
2.3	Target group	7
2.4	Modifications.....	7
2.5	Tools	7
2.6	Structure	7
2.7	Numbering	7
2.8	General instructions	8
2.9	Special instructions	8
2.10	Symbols on the machine	9
2.11	Symbols in the Workshop Manual	9

2 Introduction and safety instructions

2.1 General

This Workshop Manual describes in detail how to be troubleshoot, repair and test the machine. A description of different safety steps that must be taken during repair work is also given.

2.2 Safety

Note: The section dealing with safety must be read and understood by all those carrying out repair work or service on the trimmer/brushcutter.

Warning symbols can be found in this Workshop Manual and on the machine. See "Symbols on the machine" and "Symbols in the Workshop Manual". A new warning symbol decal must be applied as soon as possible if a warning symbol on the product has been damaged or is missing so that the greatest level of safety can be maintained when using the machine.

2.3 Target group

This Workshop Manual is written for personnel who are assumed to have general knowledge of repairing and servicing the machine.

The Workshop Manual must be read and understood by personnel who will carry out repair work and service on the machine. The Manual is also suitable for use when training new employees.

2.4 Modifications

Any modifications to the machine will be gradually introduced into ongoing production. As these modifications affect service and/or spare parts, specific service information will be sent out on each occasion. This means that in time this Workshop Manual will become out of date. In order to prevent this, the Manual should be read together with all service information concerning the machine in question.

2.5 Tools

Special tools are required for some stages. All service tools are listed in the Workshop Manual. Usage is made apparent in each section.

Always use Husqvarna's original:

- Spare parts
- Service tools
- Accessories

2.6 Structure

This Workshop Manual can be used in two different ways:

- Repair of a specific system on the machine.
- Dismantling and assembly of the entire machine.

Repair of a specific system

When a particular system on the machine is to be repaired, proceed as follows:

1. Look up the page for the system in question.
2. Carry out the following steps:

Dismantling
Cleaning and inspection
Assembly

2.7 Numbering

Position references to components inside the figures are designated A, B, etc.

The figures are numbered 1, 2 etc.

The position references and figure numbers restart in each new section.

2.8 General Instructions

The workshop where the machine is to be repaired must be equipped with safety equipment in accordance with local regulations.

No one may repair the machine unless they have read and understood the content of this Workshop Manual.

This workshop manual contains the following warning boxes in relevant places.



WARNING!
The warning box warns of the risk of personal injury if the instructions are not followed.

NOTE!

This box warns of material damage if the instructions are not followed.

2.9 Special Instructions

The fuel used in the machine has the following hazardous properties:

- The fluid and its vapour are poisonous.
- Can cause eye and skin irritation.
- Can cause breathing problems.
- Is highly inflammable.
- Running an engine in a confined or badly ventilated area can result in death due to asphyxiation or carbon monoxide poisoning.
- Use protective gloves and eye protection, goggles must comply with the ANSI Z87.1 for US or EN166 for EU countries.

When using compressed air, do not direct the jet towards your body. Air can penetrate into the blood stream, which can endanger life.

Wear protective earplugs or earmuffs when test running.

After test running, do not touch the muffler until it has cooled down. Risk of burns. Use protective gloves when working with the muffler.

Exercise care to ensure the starter spring does not fly out and cause personal injury. Wear protective glasses. If the spring tension is activated on the starter pulley when it is to be taken up, the spring can fly out and cause personal injury.

Keep in mind the fire risk. The machine may emit sparks, which cause ignition.

2.10 Symbols on the machine

The symbols below are embedded on the machine

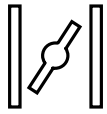

Choke control

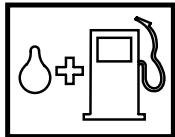

Refuelling

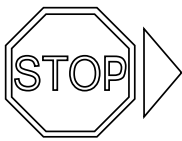

Stop switch

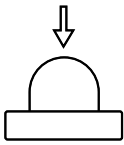

Air purge

2.11 Symbols in the Workshop Manual



This symbol warns of personal injury when the instructions are not followed.

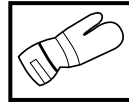

Use protective gloves.

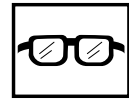

Use protective goggles.

3 Technical data



Displacement
cm³/cubic inch



Cylinder diameter
Ø mm/Ø inch



Stroke length
mm/inch

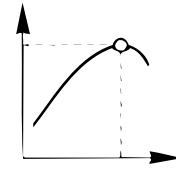

Max. output/speed
kW/rpm

	Displacement cm ³ /cubic inch	Cylinder diameter Ø mm/Ø inch	Stroke length mm/inch	Max. output/speed kW/rpm
525P4S:	25,4/ 1,55	34 / 1.34	28 / 1,10	1,0 / 8500
525P5S	25,4/ 1,55	34 / 1.34	28 / 1,10	1,0 / 8500
525PT5S:	25,4/ 1,55	34 / 1.34	28 / 1,10	1,0 / 8500

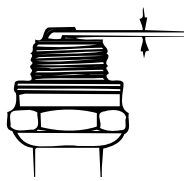

Electrode gap
mm/inch

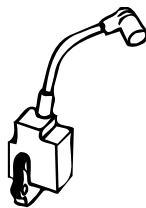

Ignition system



Air gap
mm/inch

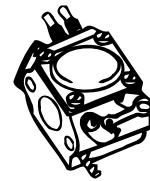

Carburetor type

	Electrode gap mm/inch	Ignition system	Air gap mm/inch	Carburetor type
525P4S:	0,65/0.025	IKEDA UK-08934-505	0,3/0.012	Walbro WTEA-8C
525P5S:	0,65/0,026	IKEDA UK-08934-505	0,3/0,012	Walbro WTEA-8C
525PT5S:	0,65/0,026	IKEDA UK-08934-505	0,3/0,012	Walbro WTEA-8C

3 Technical data

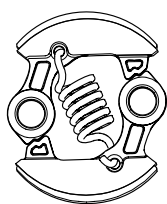

Engage speed
rpm

525P4S:	4000 (+/- 200)
525P5S:	4000 (+/- 200)
525PT5S:	4000 (+/- 200)

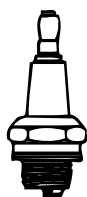

Spark plug

NGK BPMR8Y
NGK BPMR8Y
NGK BPMR8Y

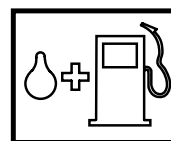

Volume fuel tank
Litres/US. pint

0,51/1,08
0,51/1,08
0,51/1,08



Weight without fuel
kg / lbs

525P4S:	4,4/9,7
525P5S:	4,6/10,1
525PT5S:	4,6/10,1

4 Engine special tools

Contents

4.1	Special tools	13
-----	---------------------	----

4.1 Special tools

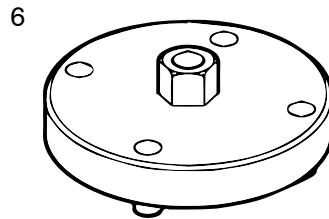
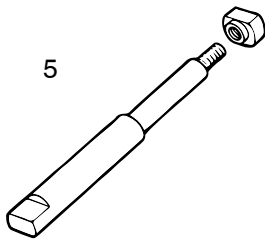
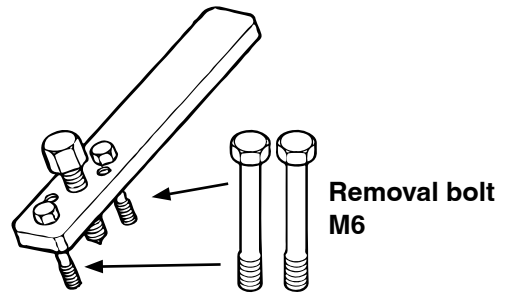
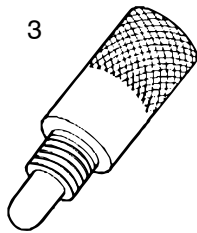
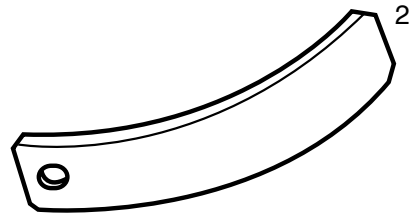
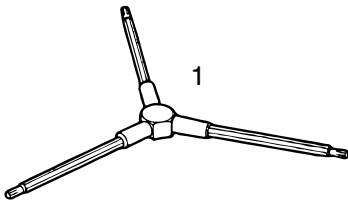

For shaft (open)

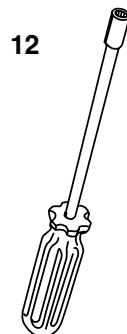
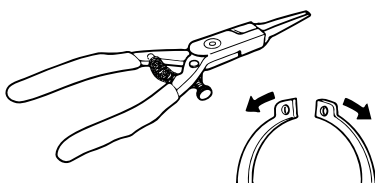
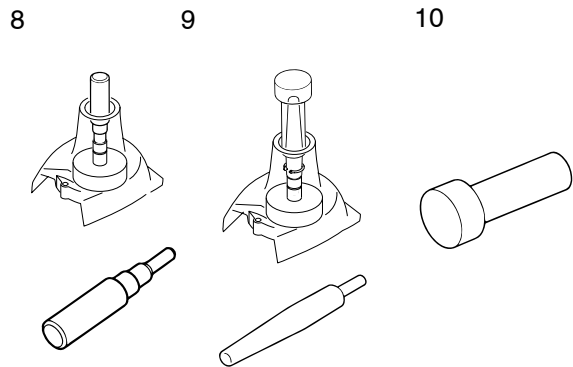
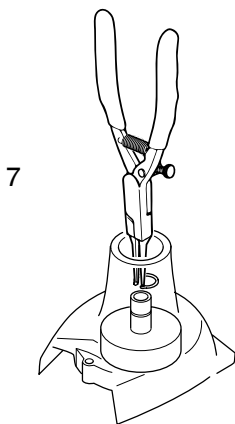

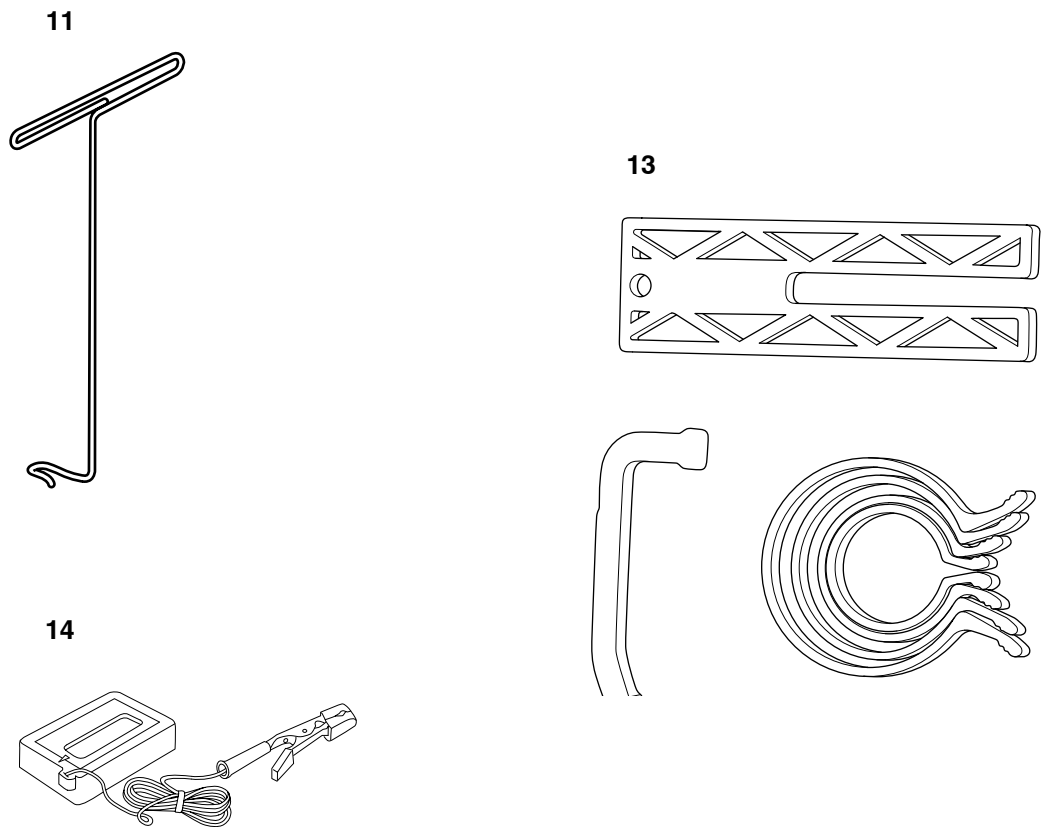

Pos	Description	Used for	Order No.
1	Torx wrench	General disassembly / assembly tasks	578 28 90-01
2	Air gap tool (t 0.3mm)	Adjust the air gap when installing the ignition module	514 22 10-01
3	Stopper (14 mm use)	Fix piston in place when installing / removing clutch, rotor and starter pulley.	514 24 39-01
4	Puller assembly	Removing the rotor (removal bolt M6)	510 13 89-01
5	Rod assembly	Installing / removing the piston pin	513 18 12-01
6	Puller	Installing / removing the recoil pulley	581 96 55-01
7	Plier	Remove Clutch drum clip	515 41 95-01
8	Rod	Remove clutch drum	581 44 10-01
9	Guide	Installing clutch drum clip	581 44 11-01
10	Guide pusher	Installing clutch drum clip	515 41 98-01
11	Hook for fuel filter	Withdrawing the fuel filter	502 50 83-01
12	Adjustment screwdriver	Adjustment of the carburetor	530 03 55-60
13	Assembly kit, piston	Assembling the piston	502 50 70-01
14	Revolution counter	Engine speed meter	502 71 14-01
	Spark plug	Testing spark plug	502 71 14-01
	Pliers	Ignition cable	502 50 06-01
	Pressure test tool	Pressure test in fuel system	531 03 06-23

5 Service data

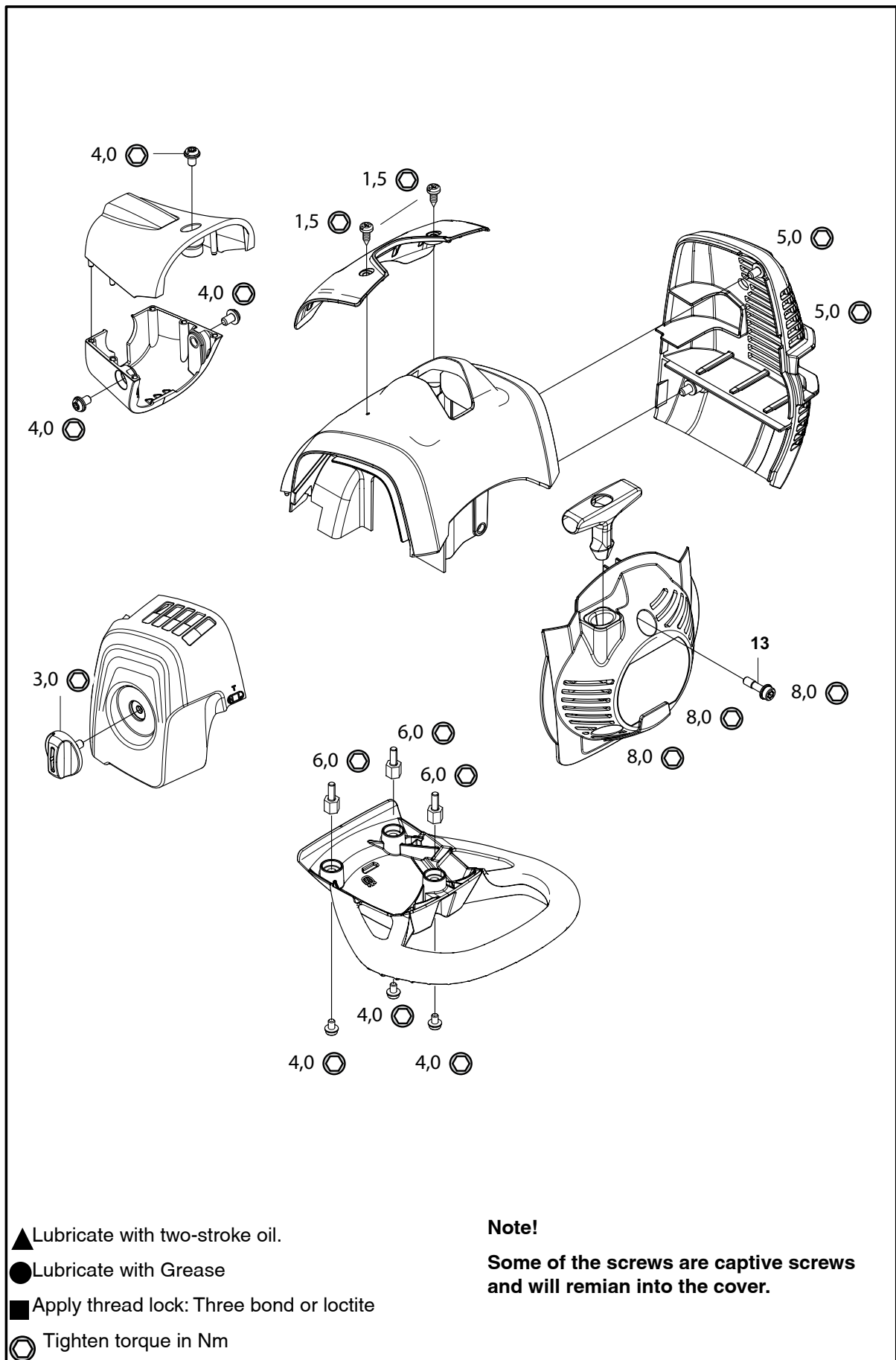

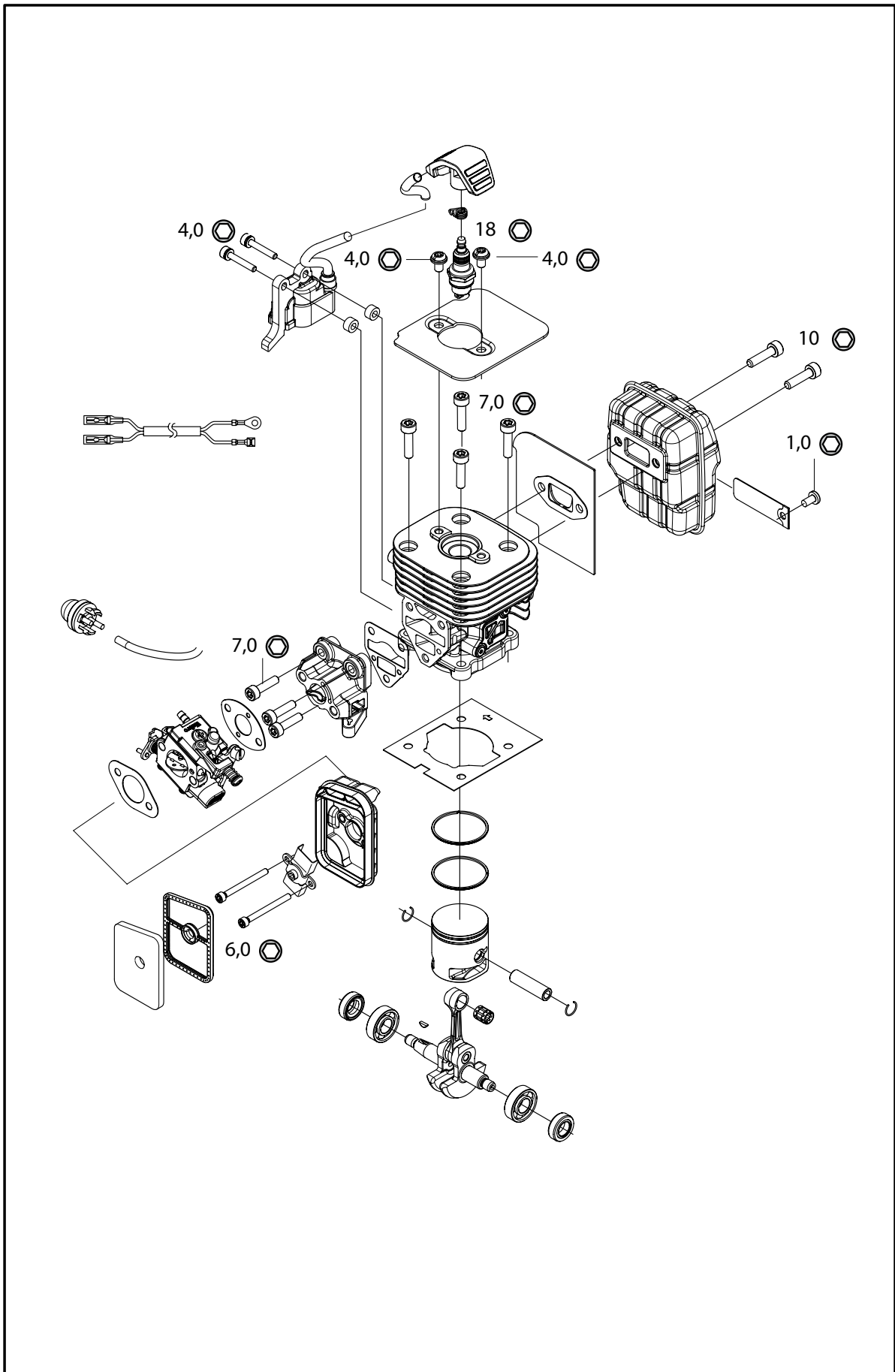

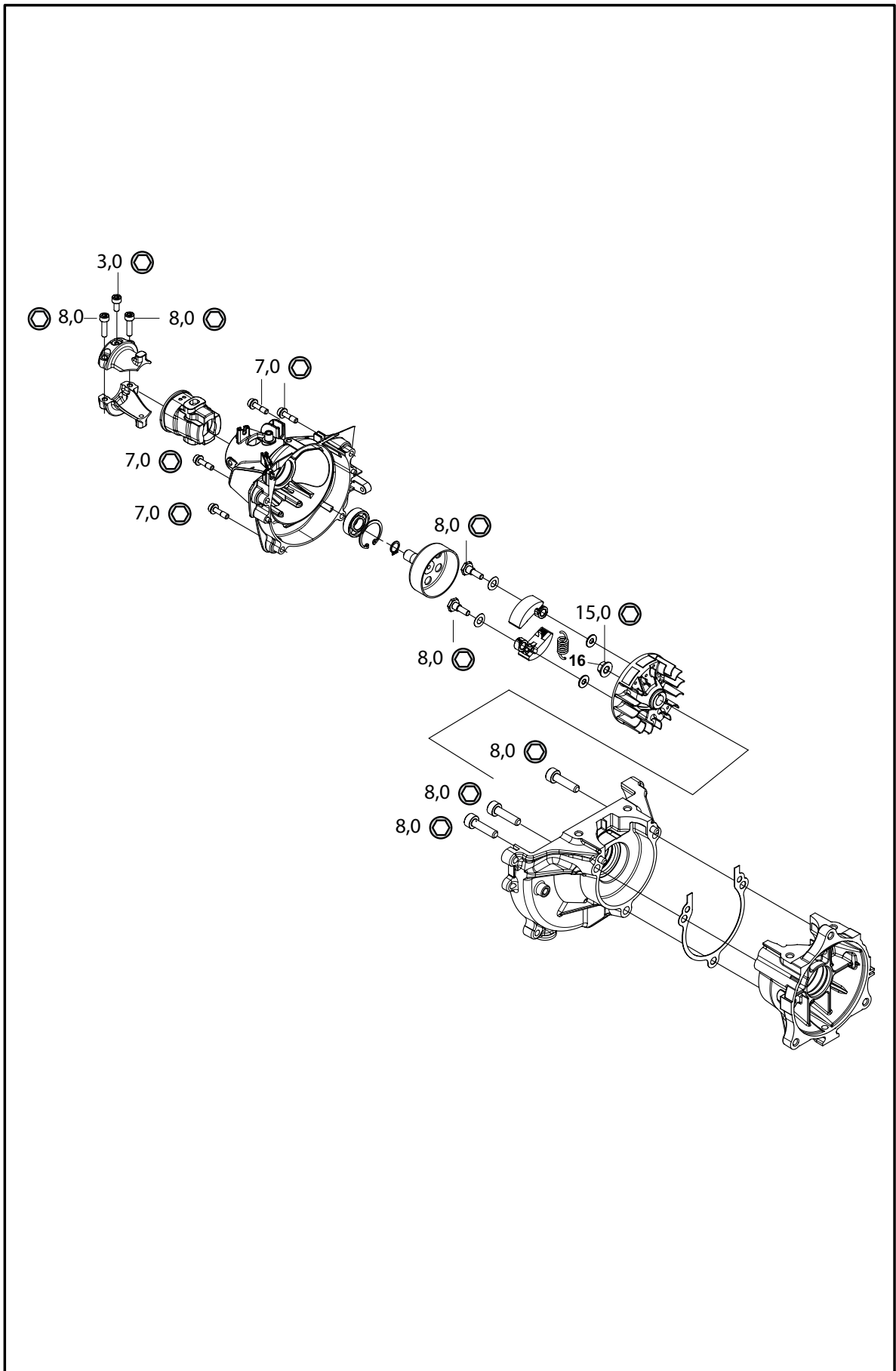

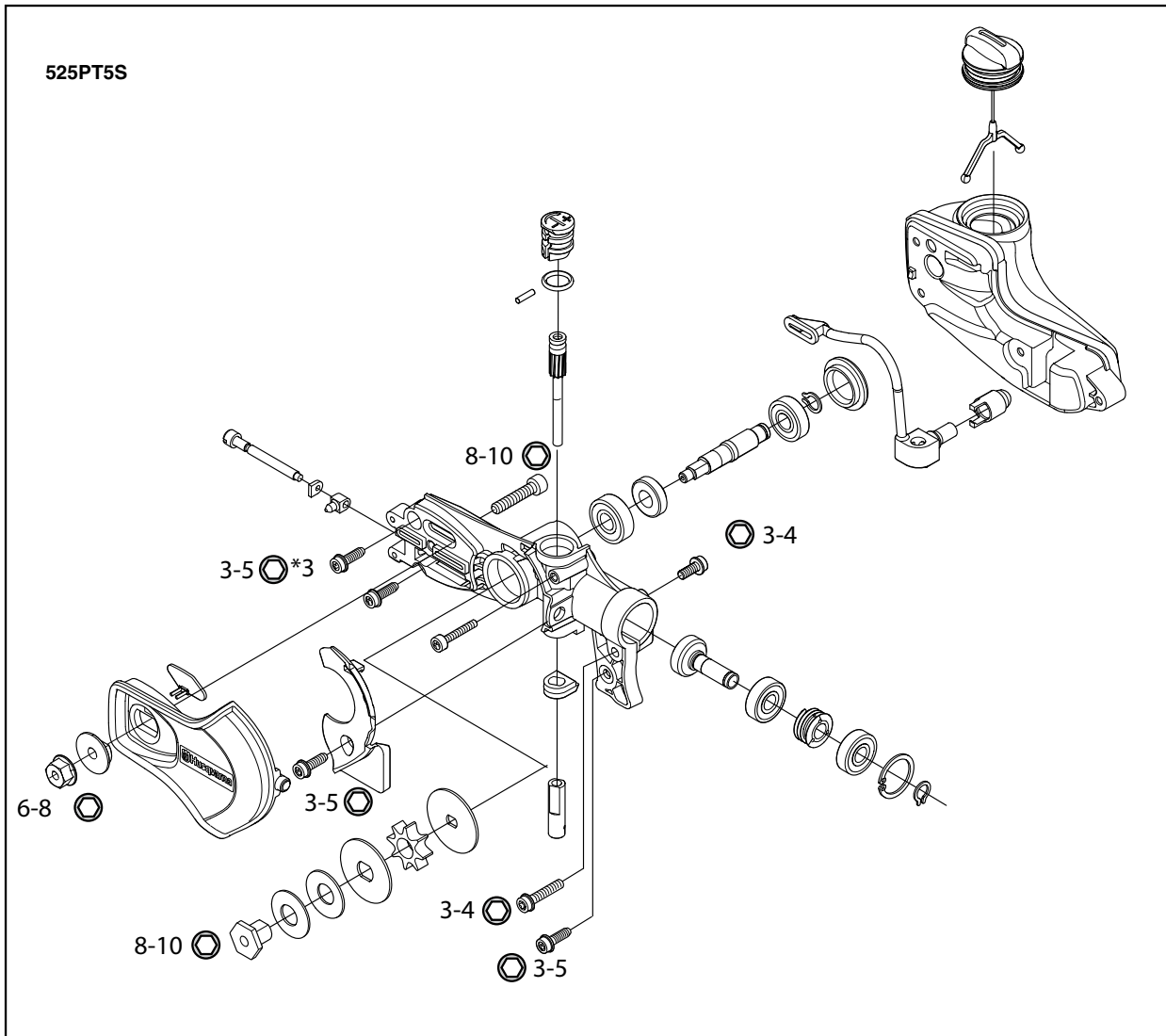

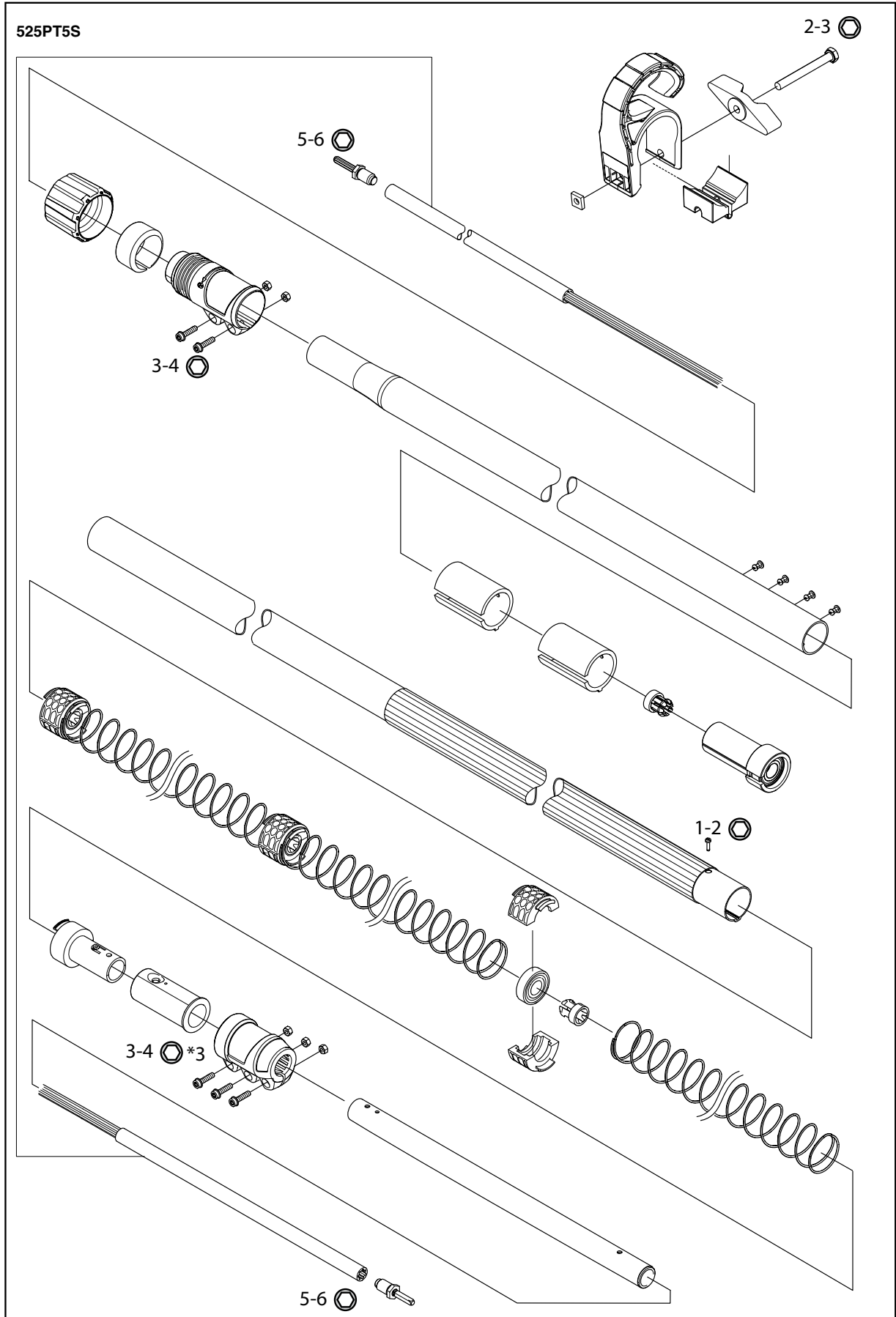

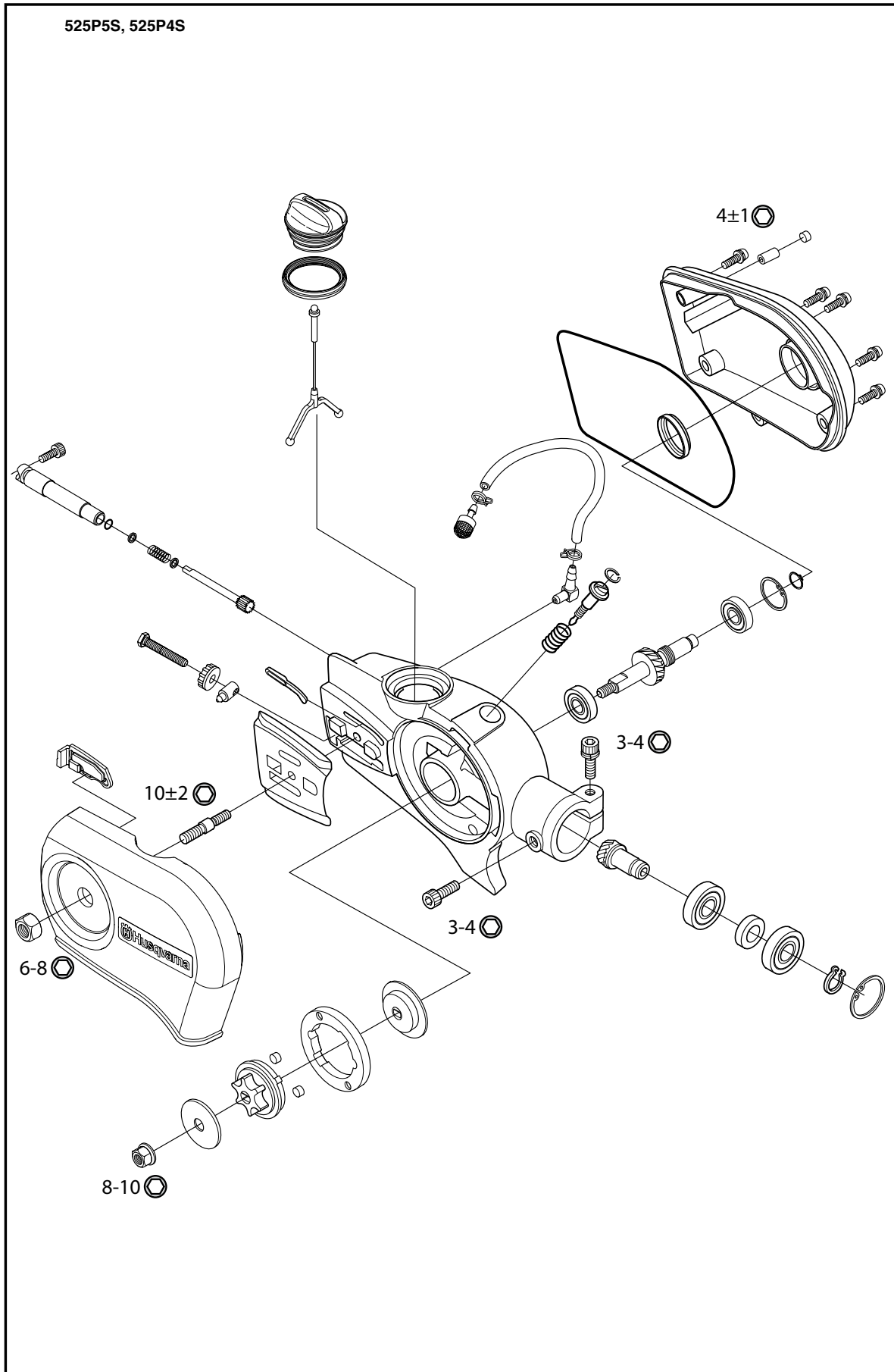

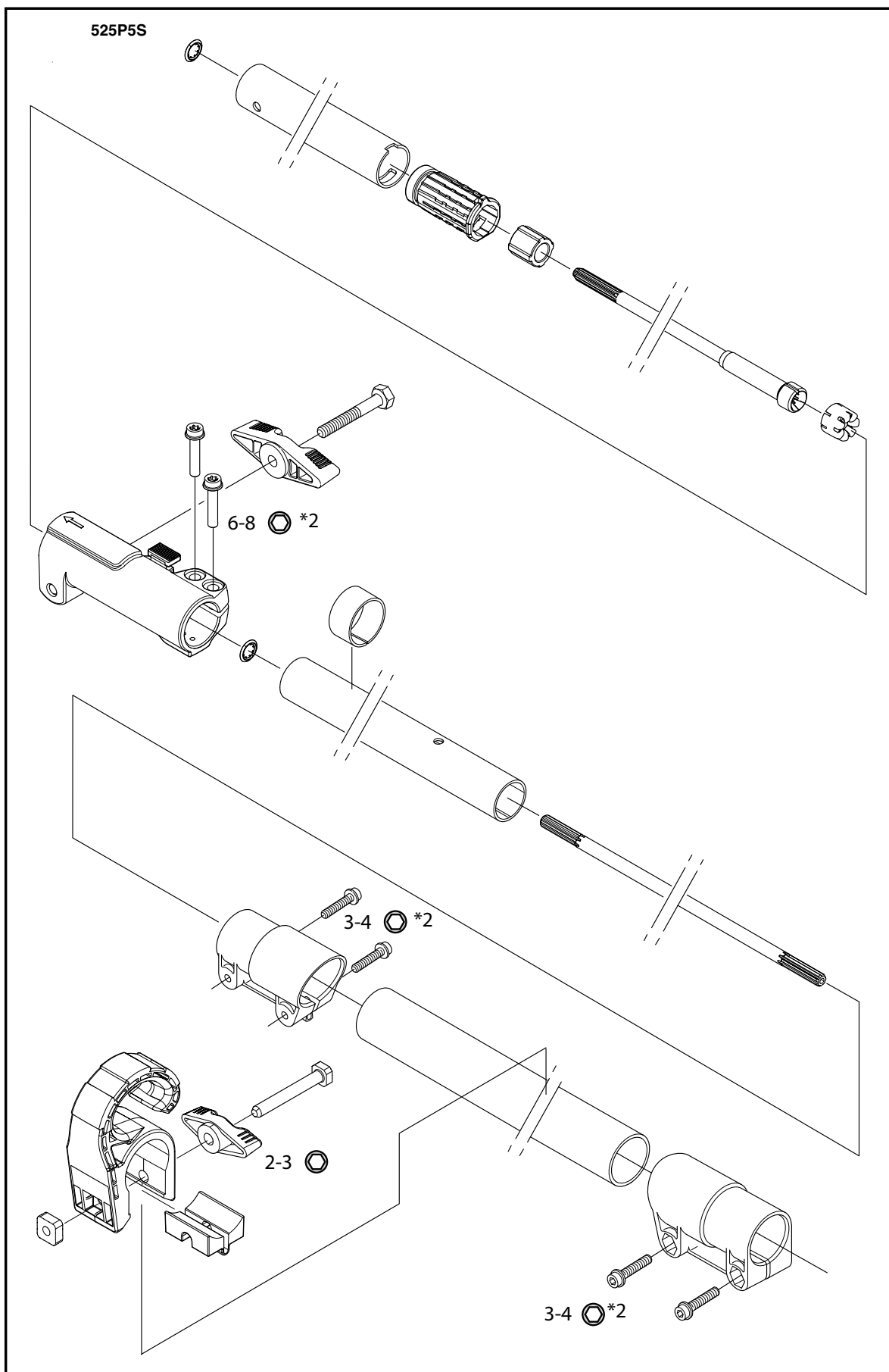

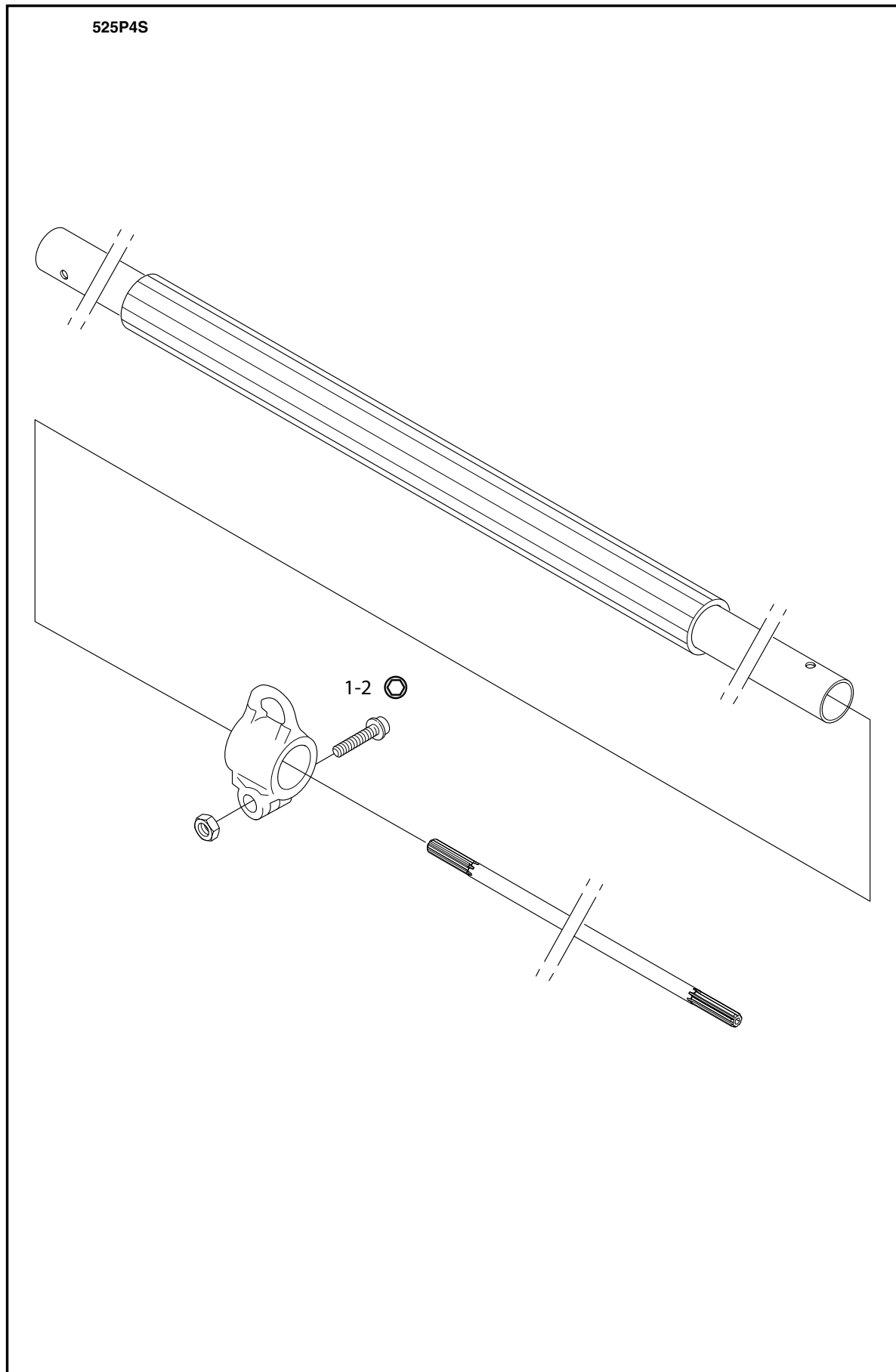

6 Safety equipment

Content

6.1	Dismantling the muffler	25
6.2	Assembling the muffler	25
6.3	Dismantling the stop switch	25
6.4	Assembling the stop switch	25
6.5	Resistance test - stop switch.....	26
6.6	Dismantling throttle.....	26
6.7	Assembling the throttle.....	27

6.1 Dismantling the muffler

Remove the cover of the muffler.

Dismantle the two screws to the muffler.
Also remove the gasket.

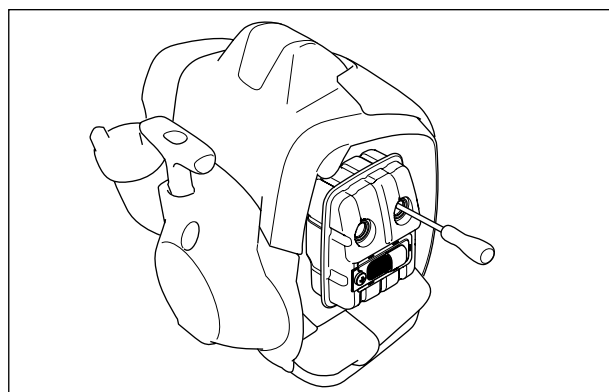

6.2 Assembling the muffler

Check the muffler, and if you find any deformation or cracks replace the muffler.

If the muffler is fitted with a spark arrestor mesh, put it in place first. Make sure the mesh is in the correct position, see illustration.

Before assembly the muffler remove carbon gently with a screwdriver.

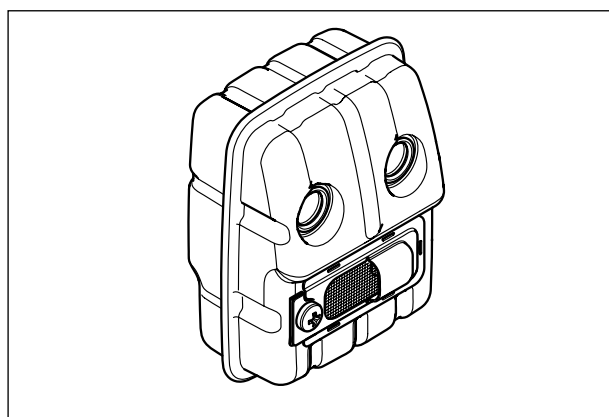

Fit the gasket and the muffler Tighten the screws. Torque 10 Nm.

Warm up the engine and retighten the screws.

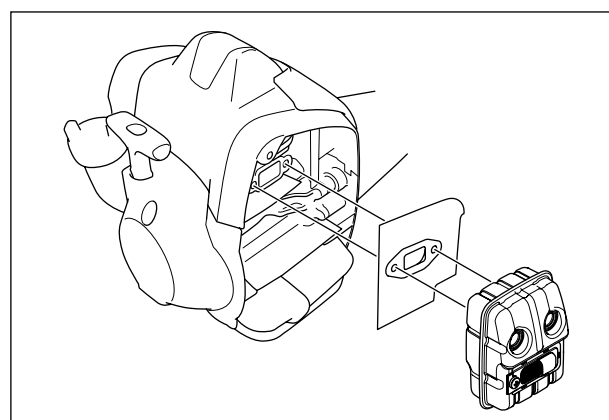

6.3 Dismantling the stop switch

Carefully remove the stop switch using a flat screwdriver or similar tool.

Disconnect the cables.

Clean and check the stop switch carefully. Parts must be replaced if cracked or show signs of other defects. Always use original spare parts.

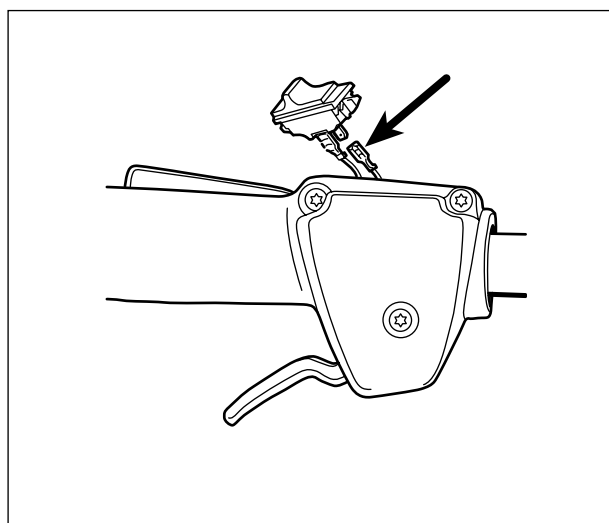

6.4 Assembling the stop switch

Connect the cables to the stop switch. Fit the stop switch.

6.5 Resistance test - stop switch

Dismantle the stop switch as outlined.

Clean the contact areas.

test the resistance by connecting a multimeter to the stop switch. The resistance should be as follow:

"0" pressed in - less than 0.1 Ω .

"1" pressed in - more than 1000 Ω .

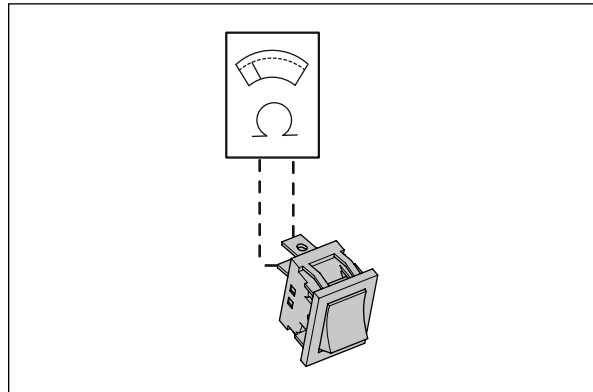

6.6 Dismantling Throttle

Assembly of the throttle is done in the reverse order as set out for dismantling.

Position the parts in the left-hand throttle half.

Dismantle the clutch housing cover from engine body, see **Dismantling the shaft from engine body**.

Remove screw that holding the shaft, (A).

Loosen the screws (B) holding the clamp around the shaft.

Remove the shaft assembly from engine body and the throttle from the shaft.

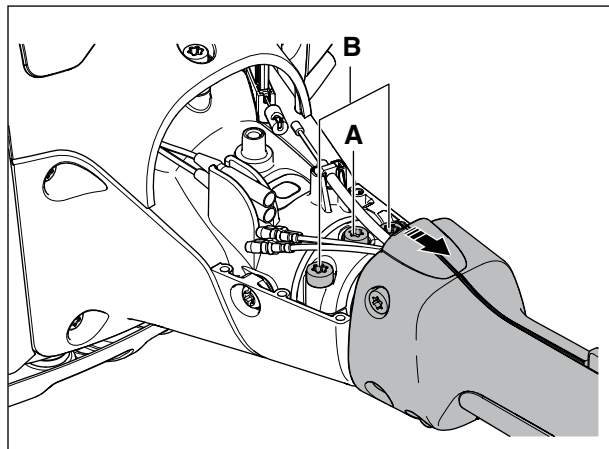

Remove the screw (C) holding the shaft.

Remove the 5 screws (D, E) holding the handle in place.

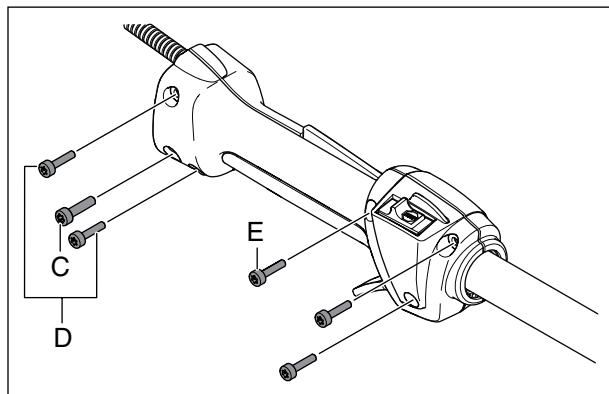

Carefully remove the right handle half and make sure that the anti vibration element (F) is not lost (one on each side of the clamping sleeve).

Note how the different parts are fitted.

Remove the clamping sleeve (G).

Note how the throttle's recoil spring (H) is fitted and remove the throttle lever.

Remove the throttle trigger lock (J) and the anti vibration element (K).

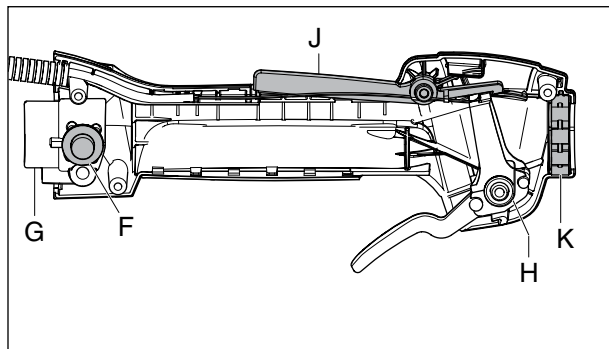

Check that the throttle cable is fitted to the **under-side** of the pin on the throttle trigger lock.

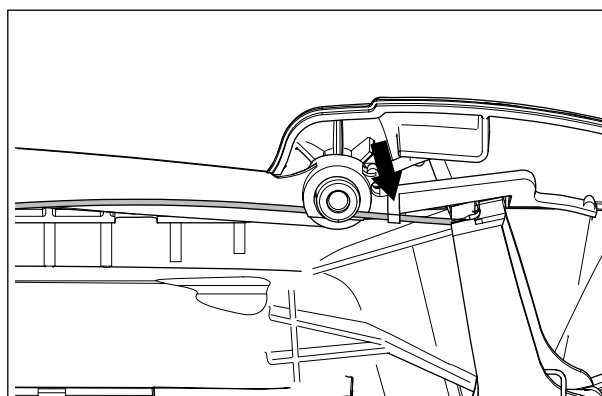

6.7 Assembling the throttle

Put all details in the left half of the handle. Make sure that the spring is correct fitted. Make sure that all cables is fitted in the handle and will not be clamped.

Assemble the throttle trigger lock (A) and the anti vibration element (B).

Fit the spring (C) and the throttle lever.

Fit the clamping sleeve (D).

Carefully put the handle together, make sure the anti vibration element is not lost.

Fasten the 5 screws (E) that holding the handle in place. Fasten the screw (F) holding the shaft.

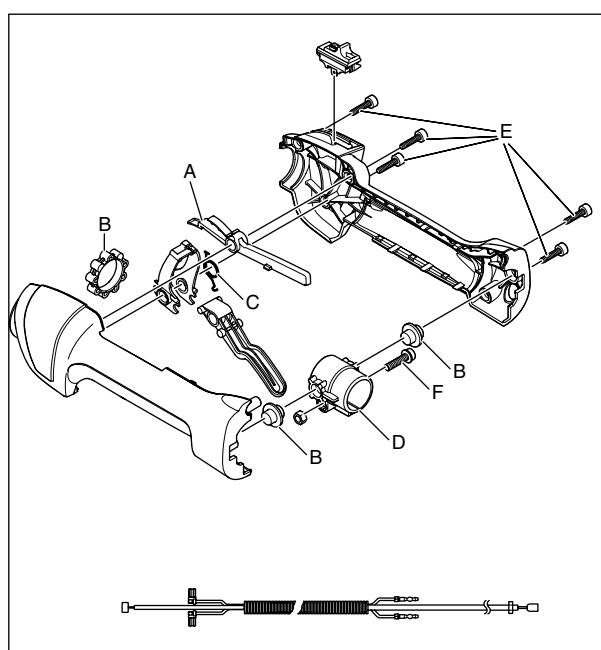

7 Repair instructions

Content

7.1	Dismantling the recoil pulley.....	29
7.2	Assembling the recoil pulley.....	29
7.3	Replacing the starter pawls.....	31
7.4	Checking the ignition spark.....	32
7.5	Dismantling the shaft and clutch housing from engine body.....	34
7.6	Assembling the shaft and clutch housing from engine body.....	34
7.7	Adjust the air gap when installing ignition module.....	35
7.8	Fuel system.....	36
7.9	Dismantling and assembling the air filter.....	36
7.10	Tank venting.....	36
7.11	Replacing the fuel filter.....	37
7.12	Air purge.....	37
7.13	Carburetor.....	37
7.14	Dismantling the carburetor.....	39
7.15	Assembling the carburetor.....	42
7.16	Carburetor settings.....	44
7.17	Dismantling, centrifugal clutch, flywheel, ignition module.....	46
7.18	Assembling, centrifugal clutch, flywheel, ignition module.....	48
7.19	Dismantling the cylinder and piston.....	49
7.20	Cleaning, inspection.....	51
7.21	Analysis and actions.....	51
7.22	Assembling the piston and cylinder.....	58
7.23	Dismantling, crankshaft and crankcase.....	59
7.24	Assembling, crankshaft and crankcase.....	61
7.25	Replacing the clutch drum and drive shaft.....	62
7.26	Dismantling and assembling, clutch drum and drive shaft.....	62
7.27	Dismantling the saw head (PT5S).....	65
7.28	Assembling the saw head (PT5S).....	67
7.29	Dismantling the telescopic tupe (PT5S).....	69
7.30	Assembling the telescopic tupe (PT5S).....	70
7.31	Assembly saw head, shaft and engine(PT5S).....	72
7.32	Dismantling the shaft (P4S, P5S).....	73
7.33	Dismantling the saw head (P4S and P5S).....	74
7.34	Assembling the saw head (P4S and P5S).....	77
7.36	Assembling saw head, shaft and engine(P4S and P5S).....	77

7 Repair instructions

7.1 Dismantling the recoil pulley

Remove the 3 screws and lift off the starter

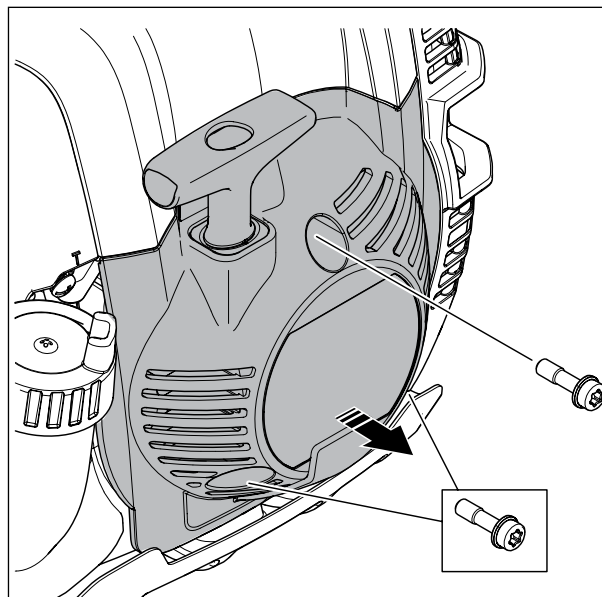

Remove the inner cover in the starter housing. Use a flat screw driver or similar tool.



WARNING!
Wear protective glasses. The return spring lies tensioned in the starter and can fly out and cause personal injury with careless handling..

Offload the spring tension.
Lift up the starter cord on the starter pulley and allow it to rotate clockwise. Slow the rotation with your thumb.
Remove the screw in the centre of the starter pulley. Carefully lift out the starter pulley from the starter housing.

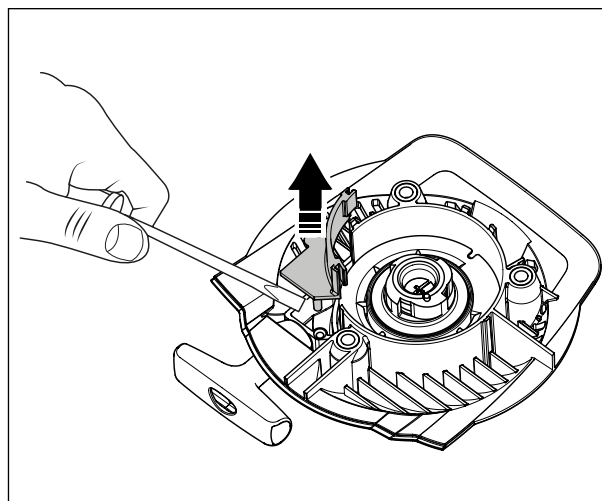

7.2 Assembling the recoil pulley

Clean component parts before assembling.
Replace the return spring/starter pulley and starter cord, if necessary.

NOTE!

The return spring and starter pulley are supplied pre-assembled and are fitted in the starter housing as a single unit.
Exercise care when opening the packaging so that the spring does not fly out.

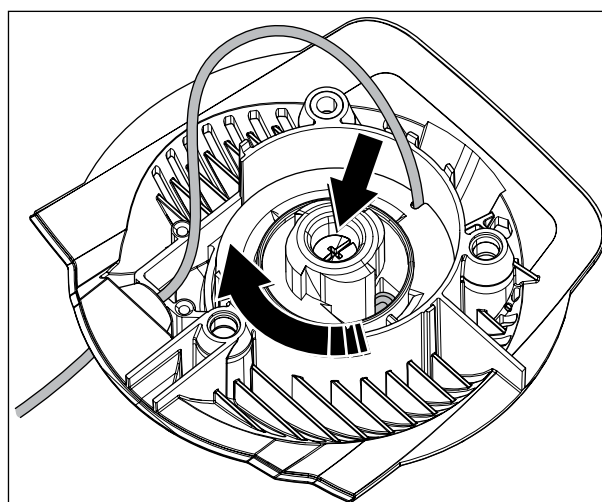

Lubricate the spindle with a little grease and fit the starter pulley. Tighten the screw.
Assemble a new starter cord. Slide it into the starter pulley's slot as illustrated and then out through the cord guide in the starter housing. Make sure the knot on the end of the cord is as small as possible!

NOTE!

A new starter cord can be fitted without the need of dismantling the starter!

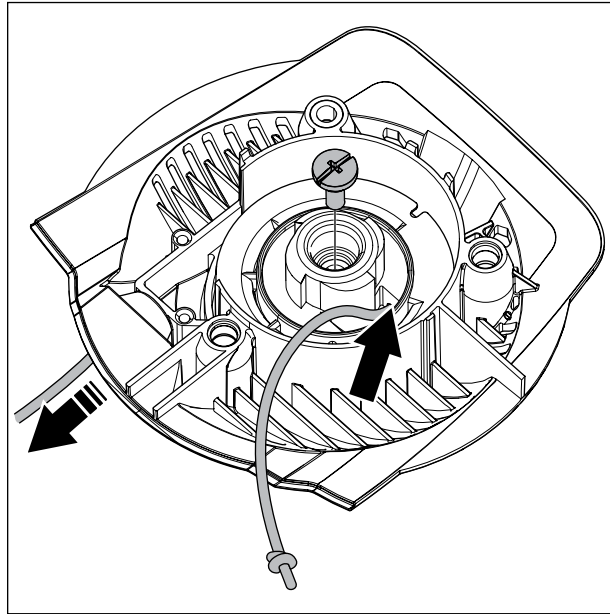

Assemble the starter handle.
Tie a double knot and fold under the free end.
Pull the knot fully into the handle.

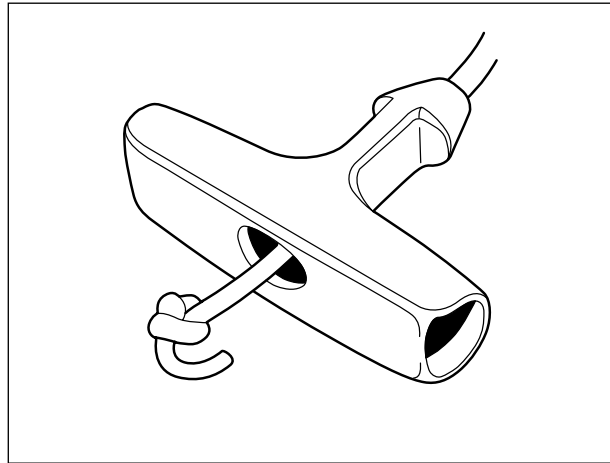

Tension the return spring.
Pull the starter cord out completely and slow the starter pulley with your thumb.
Lift the cord into the notch on the starter pulley.
Now turn the starter pulley counterclockwise, 6 turns.
Check the spring tension. With the starter cord fully extended it should still be possible to turn the starter pulley further, at least a half turn.

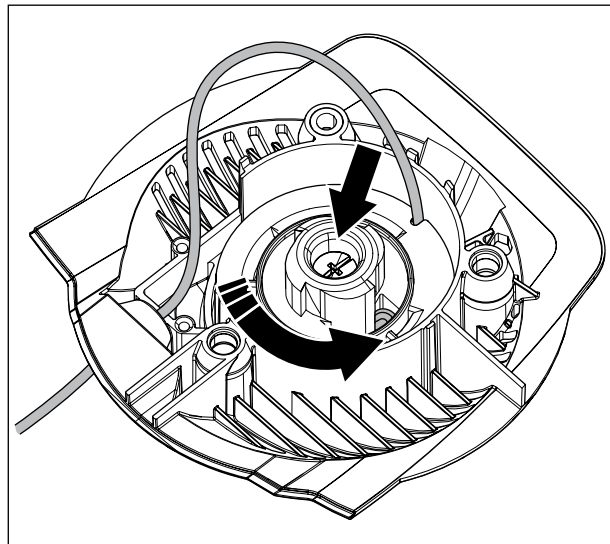

7.3 Replacing the starter pawls

Fit the piston stop(A), no. 514 24 39-01 in the spark plug hole and loosen the starter pulley using special tool 581 96 55-01 (B).

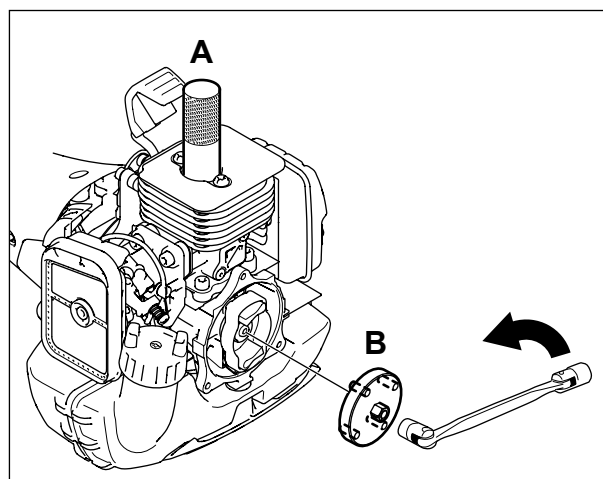

Remove the circlip holding the starter pawls. Lift out the starter pawls and spring for replacement. Assemble in the reverse order as set out for dismantling.

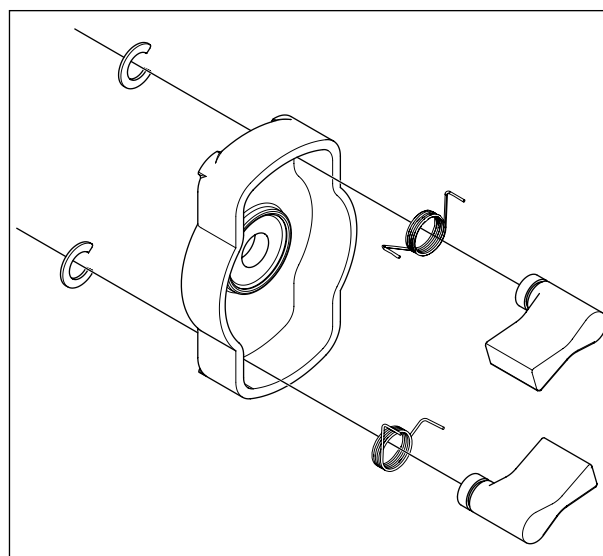

7.4 Checking the ignition spark

Dismantle the cylinder cover after the guard over the muffler and the air filter has been removed. Earth the spark plug on the cylinder and pull sharply on the start handle. A spark should be seen between the electrodes. If no spark is seen test with test spark plug no. 502 71 13-01. If a spark then occurs, the spark plug is faulty. Try a new spark plug.

If there is still no spark, remove the short-circuit cable from the stop switch. Prise up the switch by inserting a small screwdriver into the short end of the ignition switch. If the plug now sparks, the fault is either in the stop switch or the short-circuit cable. Change the switch as needed and check to see if the cable insulation is damaged.

Still no spark?
Check the spark plug connection. Remove the spark plug cap and make sure the ignition cable is not damaged. Remove a segment of cable if required to get sufficient contact at the connection coil.

TIP!

Spray the ignition cable with silicone to make it easier to pull off the spark plug cap.

When a part of the ignition cable has been cut off it helps to use pliers no. 502 50 06-01 to make a new hole in the ignition cable to fit the ignition coil.

NOTE!

It is important that the tip of the contact coil hits the centre of the ignition lead to prevent sparking.

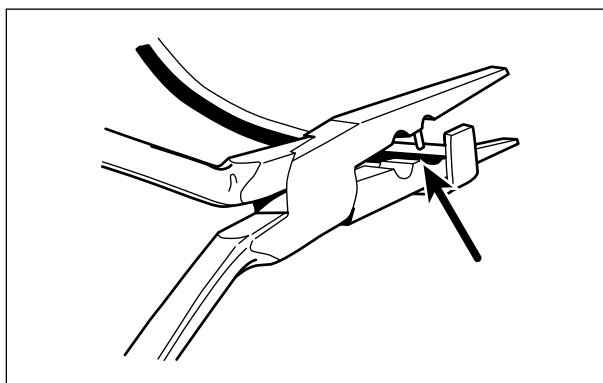
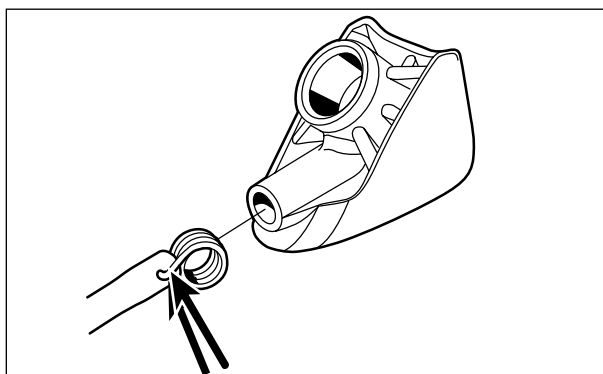
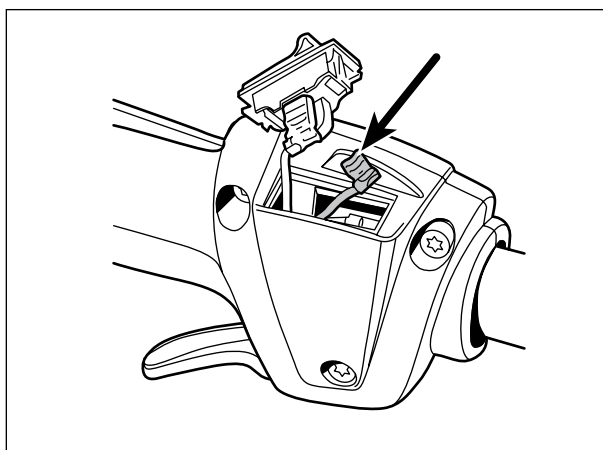
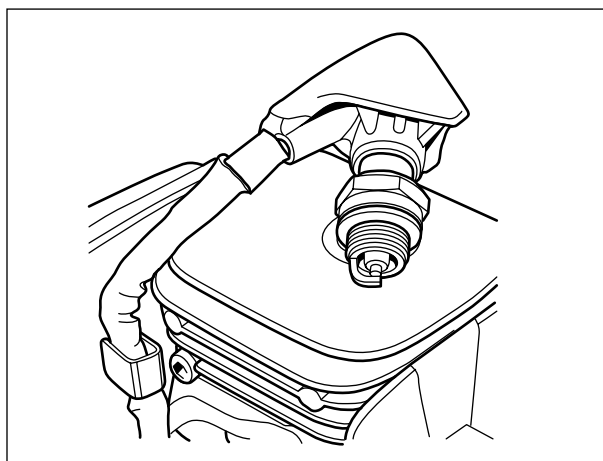

Fit the spark plug cap onto the ignition cable and make sure the ends of the wire is inserted into the centre of the spark plug cap for best contact.

TIP!

Lubricate the hole in the spark plug guard using for instance silicon spray to make it easier to push the ignition coil in.

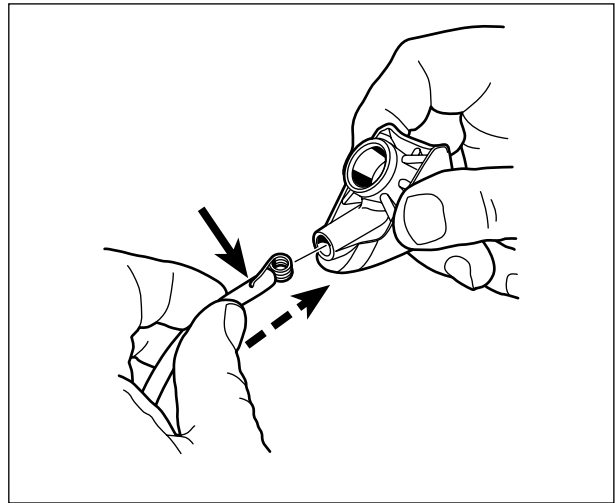

Still no spark?

Check other cables and connections for poor contacts (dirt, corrosion, cable breakage and damaged insulation). Make sure that the cables are correctly drawn and lie in the cable grooves.

Do not forget to check the cables in the handle.

TIP!

Use an Ohmmeter in order to easily check if cable breakage has occurred, due to pinching, for example.

Still no spark?

Change ignition module.

Disconnect the cables from the ignition module.

Remove the two screws holding the ignition module.

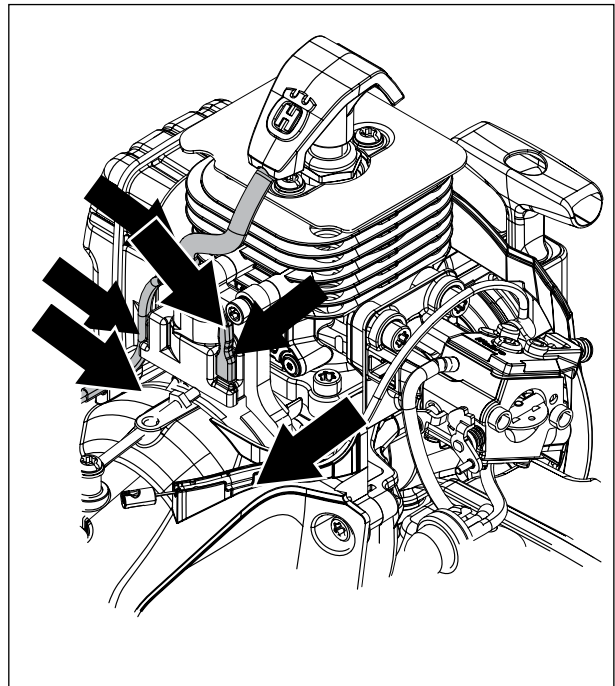

7.5 Dismantling the shaft and clutch housing from engine body

Remove the cylinder cover, guard over the muffler, and the air filter.

Unhook the throttle cable from the carburetor and insulator.

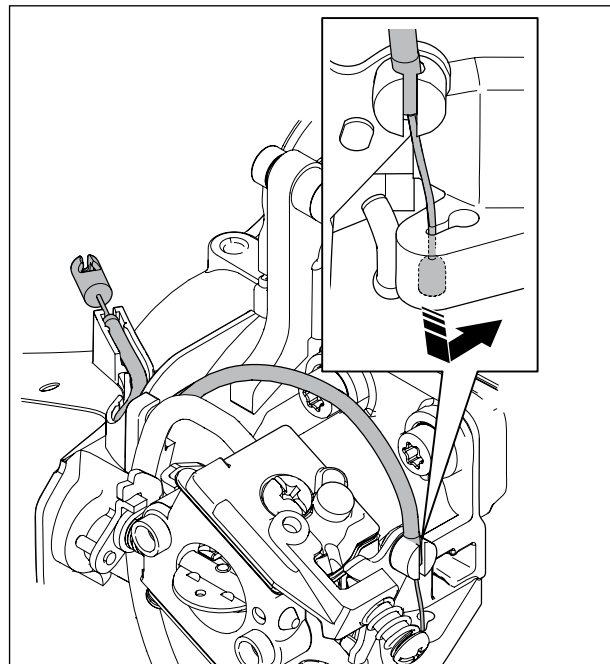

Disconnect the cables from ignition module.
Remove the screws holding the clutch housing on the engine.

Lift off the cover together with the shaft.

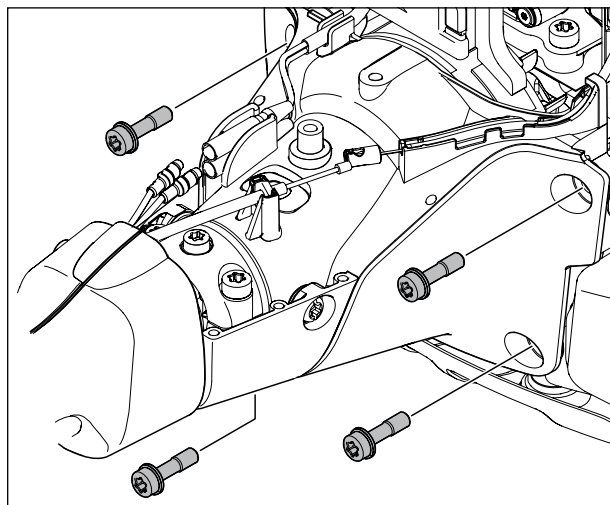

7.6 Assembling the shaft and clutch housing to the engine body

Put the clutch housing on the engine. Fasten the screws to the engine body.

Connect the cables from the ignition module. Do not pinch the cables.

Connect the throttle wire with the carburetor.
Fasten the screws holding the clutch cover.

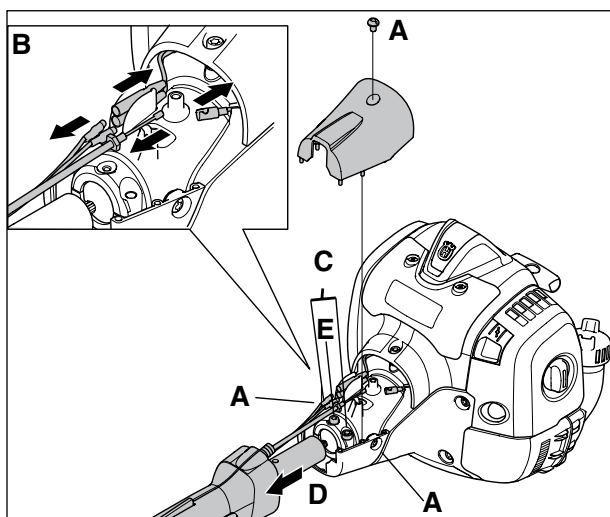

7.7 Adjust the air gap when installing the ignition module

1

Adjust the air gap as needed to the correct value.

- Loosen the bolts.
- Position the gauge to adjust the gap and press the ignition module against the flywheel.
- Tighten the bolts and check the air gap again.

If the spark plug still does not fire, the ignition system should be replaced.

Torque: 4.0 Nm.

Fig 5	
A	Rotor
B	Gauge
C	Ignition module

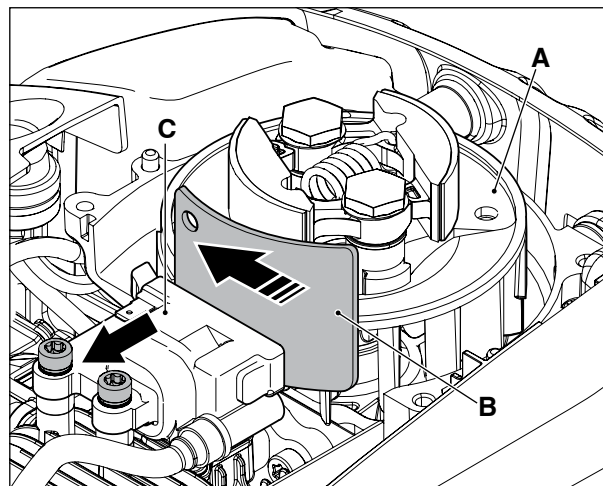

See Fig for Ignition module model (D) and Article No (E).

Engine Model	Ignition module	Module Resistance Value	
525	UK08934	Primary (Iron Core↔Primary Terminal): 80 kΩ±20%	Secondary (Iron Core↔High-Voltage Wire): 4 kΩ±10%
524	505		

Air Gap	Gauge Model No.
0.3 mm	514 22 10-01

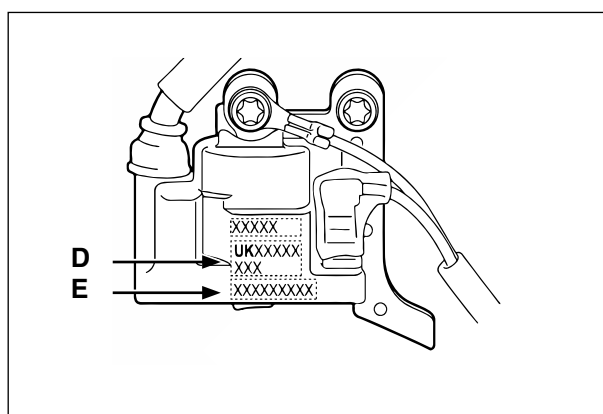

The stated resistance value is only a guideline figure when measuring with the tester. Internal leaks and the like are not detected, even if a resistance value is given. A gap tester is also available as a measurement component, as a spark tester for measuring the strength of sparking even during engine operation. Fig to the left is a 3-core gap tester.

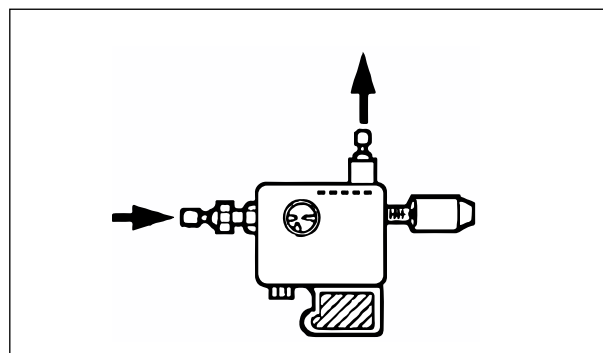

7.8 Fuel system

In addition to the fuel tank and carburetor, the fuel system consists of the air filter, fuel filter and tank venting.

All these components interact so that the engine receives the optimal mixture of fuel and air to make it as efficient as possible. Very small deviations in the carburetor setting or a blocked air filter have a large effect on the running and efficiency of the engine.

The carburetor can come from several different manufacturers on our models, but the function and repair methods are essentially the same.

7.9 Dismantling and assembling the Air filter

Remove the cover over the carburetor and lift off the air filter. The filter (A) is made of Urethan foam and must be cleaned with warm soapy water. The filter (B) is a Felt filter and must be cleaned with compressed air from the clean side to the drive side.

A damaged filter should be replaced with a new filter.

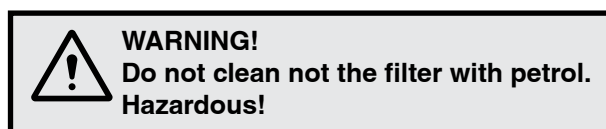

Assembly the air filter in revers order.

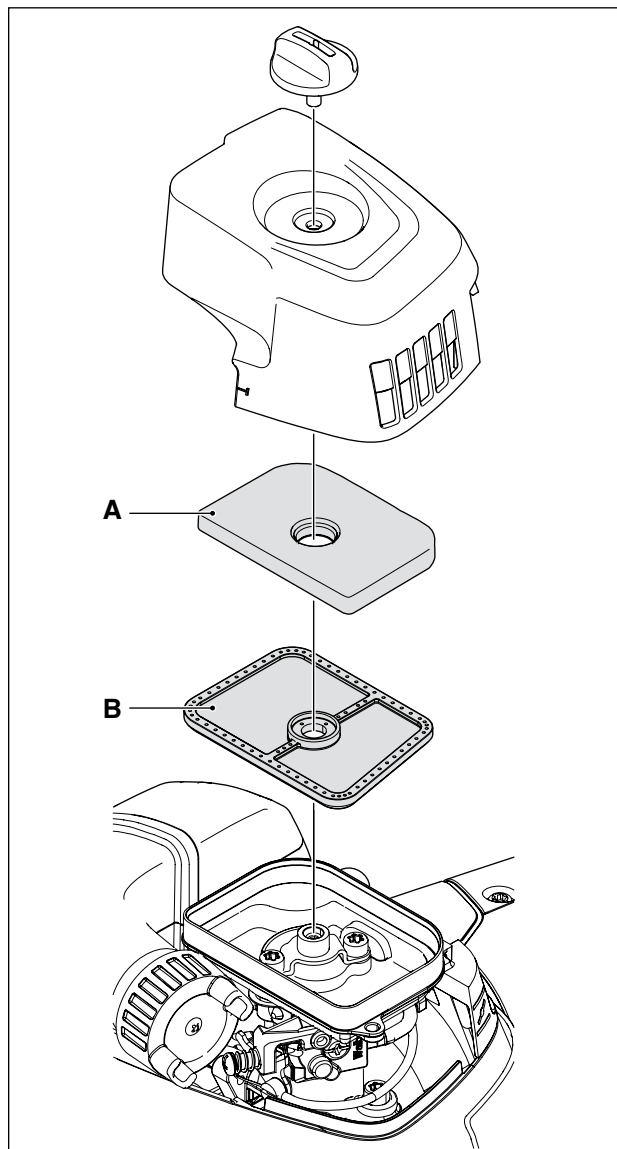

7.10 Tank venting

Tank venting takes place through the fuel cap and needs to be functional for the engine to work.

- Remove the fuel hose from the carburetor and empty the fuel from the tank.
- Connect the fuel hose to pressure tester no. 531 03 06-23.
- Pump up a vacuum of 50 kPa (0.5 bar) in the tank.
- The pressure should drop to 20 kPa (0.2 bar) or revert to atmospheric pressure within 45 seconds.

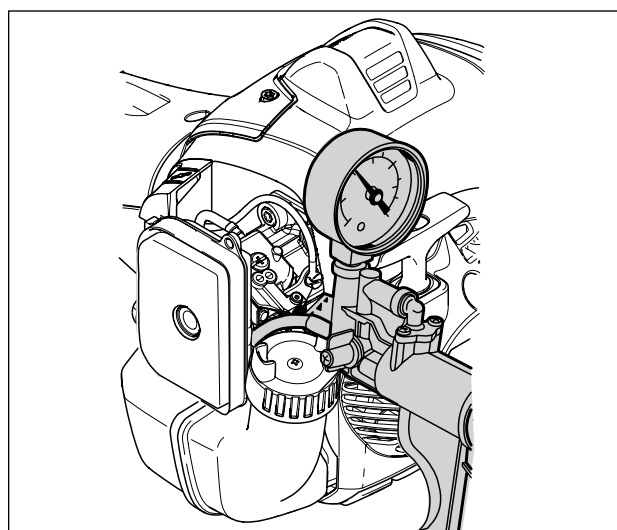

7.11 Replacing the fuel filter

The fuel hose in the tank contains a fuel filter. It is accessible through the fill hole. Pull out the filter with your fingers or with help of tool 502 50 83-01.

If the filter is not too dirty, its surface can be cleaned with a brush.

Otherwise it must be replaced.

Check the fuel hose for cracks and leaks.

Make sure that the filter's connection neck is inserted as far as possible into the fuel hose and that the clip is sufficiently tight so that the filter cannot slide off the tube.

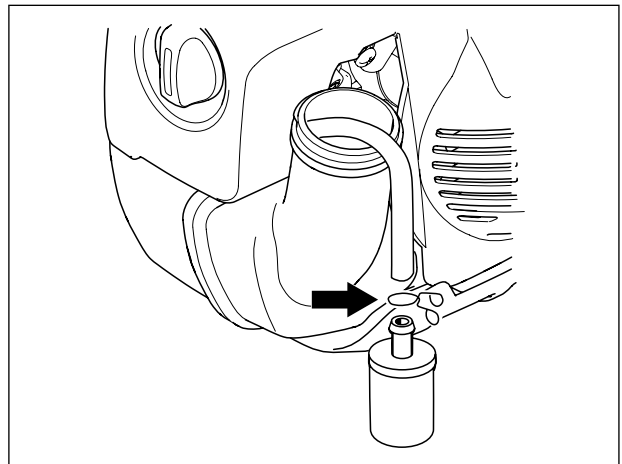

7.12 Air purge

The fuel pump has the task of facilitating the start of the engine when cold. The pump fills the carburetor with fuel before attempting to start the engine. This also prevents bubbles from blocking the narrow fuel channels.

If the pump does not work it must be replaced.

Note how the fuel hoses are connected to simplify assembly.

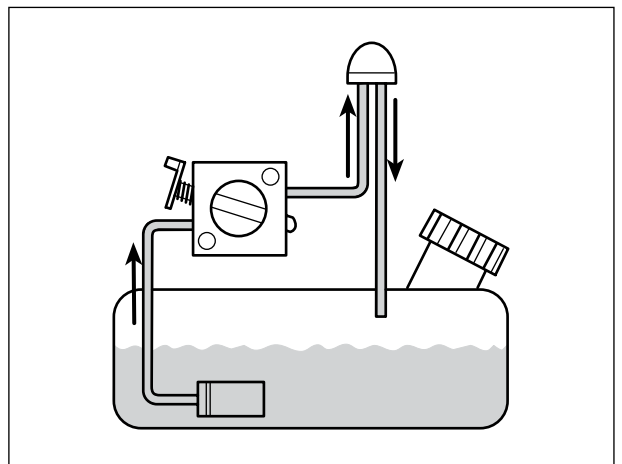

7.13 Carburetor

1. Remove the air filter cover and blow the carburetor compartment clean with compressed air.
2. Disconnect the throttle cable from the lever arm on the carburetor and from the guide in the insulator.
3. Remove carburetor screws and the fuel pipe.
4. Move the air filter housing to the side, remove the fuel pipe and lift off the carburetor.

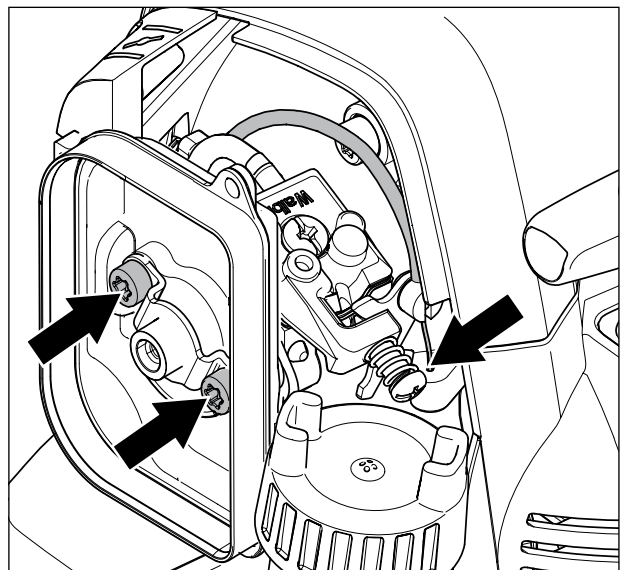

The carburetor's design

The carburetor can be divided into three different functional units: the metering unit, the blending unit, and the pump unit

The metering unit

The needles (A) and the fuel control functions are located here.

The needle valve (B) and control diaphragm (C) are vital to the carburetor's function.

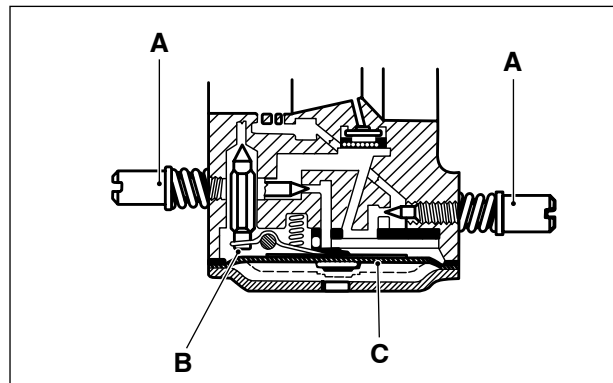

The blending unit

In this section of the carburetor fuel and air are mixed in the proper proportions.

The choke valve (D) and throttle valve (E) are placed here.

In the middle of the venturi (narrowest part of the throughput) the main jet (F) is found.

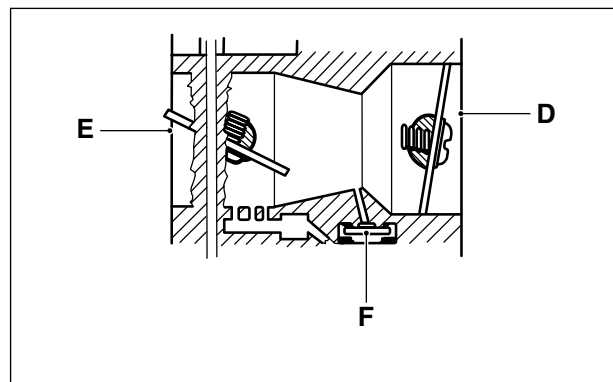

The pump unit

This is where the pump diaphragm (G) that pumps fuel from the tank to the carburetor's measuring unit is found.

The diaphragm is affected by pressure variations in the engine's crankcase via an impulse channel (H). If the channel is blocked, by grease or a wrongly facing gasket, for example, the pump unit does not function and the engine cannot be started.

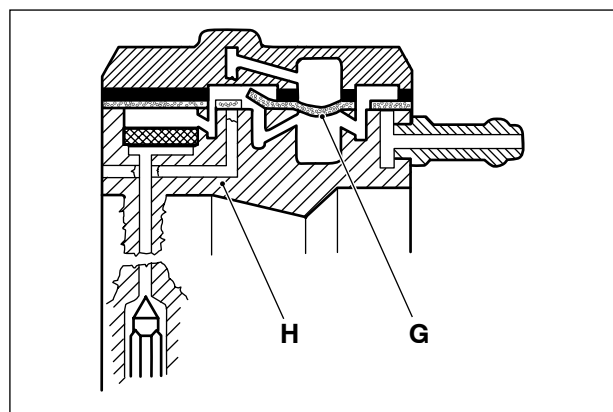

7.14 Dismantling the carburetor

Carefully remove the metering diaphragm (A) and gasket (B).

Check the diaphragm for holes and wear on the pin (C).

Replace the diaphragm if required.

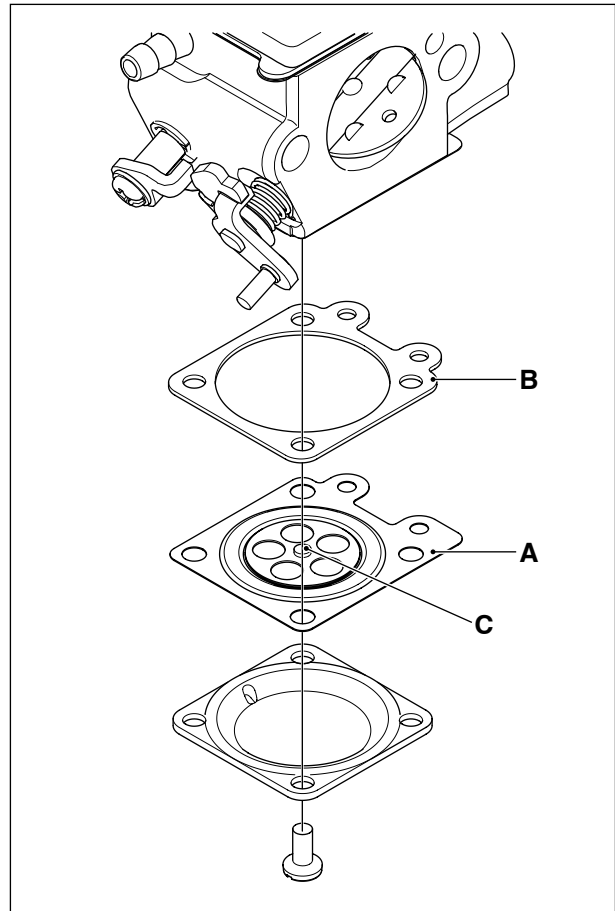

Connect pressure tester 531 03 06-23 to the fuel hose nipple.

Lower the carburetor in a vessel with petrol in order to discover any leaks more easily.

Test the pressure at 50 kPa.

No leakage is permitted.

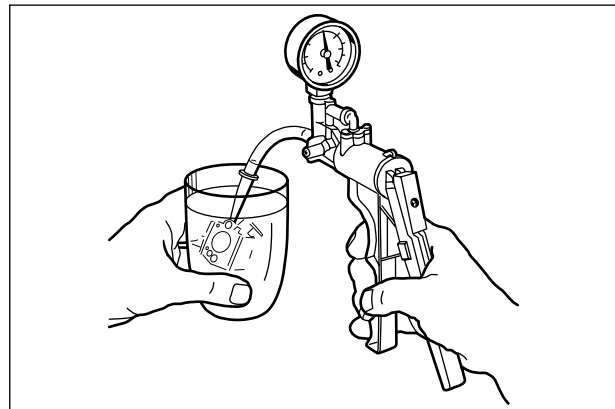

In the event of leakage – remove the needle valve. Loosen the bolt and remove the lever arm, axle, needle valve and spring.

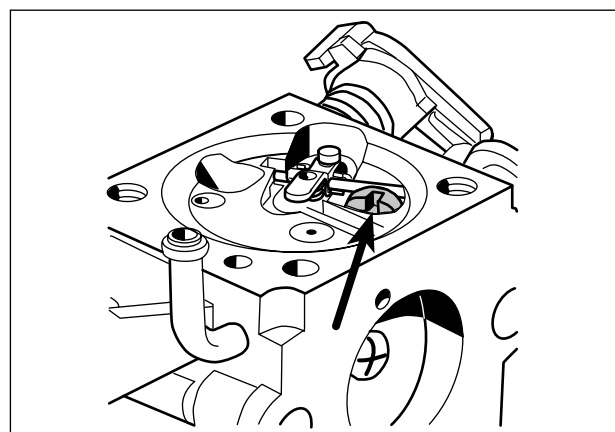

Check the needle valve for damage on the tip (D) and in the lever arm groove. (E)

Check the lever arm for damage to the groove (F) for the needle valve and wear on the mounting points towards the control diaphragm (G).

Replace damaged components with new ones.

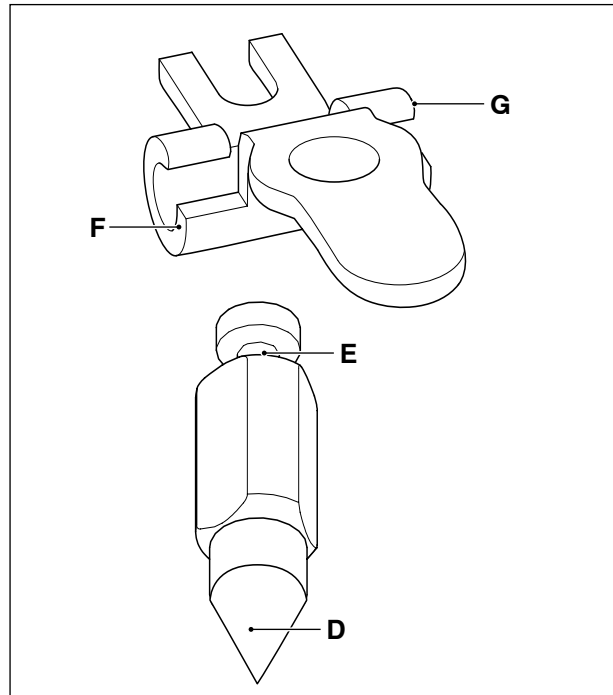

Remove the bolt holding the cover over the pump diaphragm.

Lift off the cover (H), the gasket (J) and the diaphragm (K).

Check the diaphragm for damage to the valve tongues. If the valve tongues are bent, the pump will not function in a satisfactory manner.

Hold it up to a light as well to discover any holes in the material.

Carefully remove the fuel screen (L), using a needle for example. Clean or replace the fuel screen.

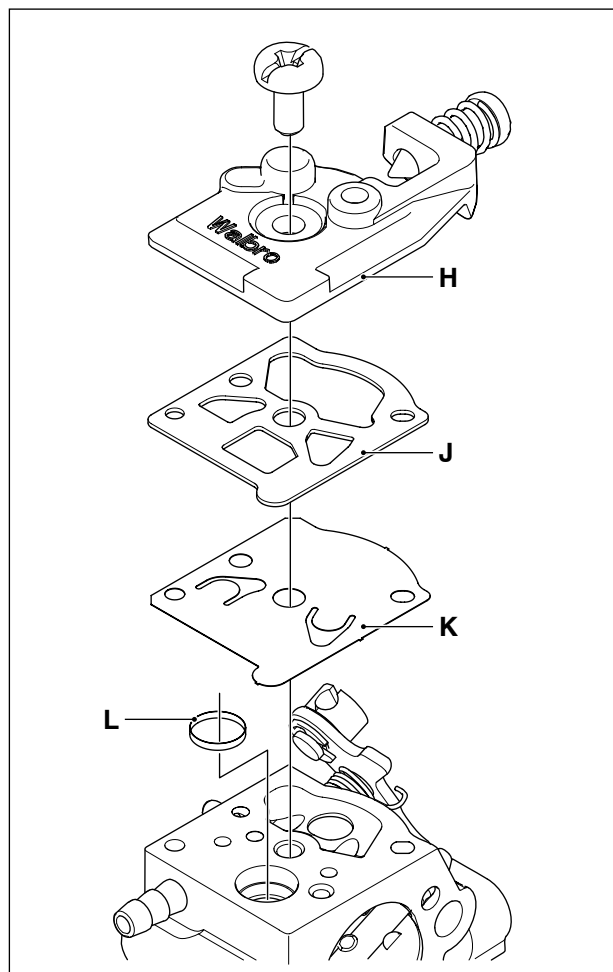

NOTE!

During assembly the pump diaphragm should lie closest to the carburetor housing.

Unscrew the jet needles. Make sure they are clean and not damaged on the tip of the needle.

NOTE!

**Note how the jets are positioned.
(For example, the H-needle is a little shorter than the L-needle).**

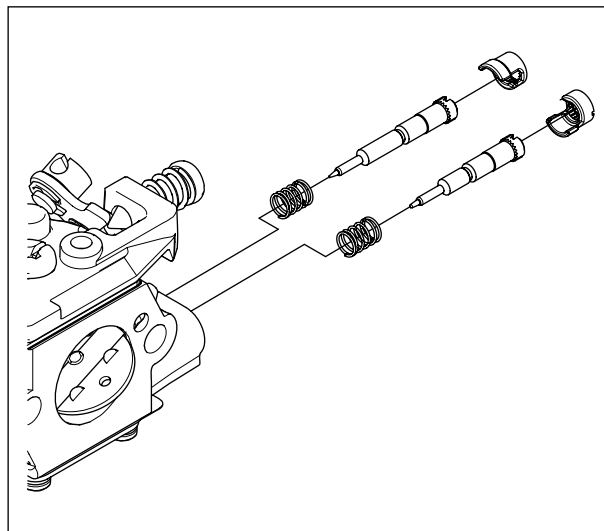

Press out the main jet (A) with a suitable punch.

Remove the plug (B).

Carefully drill a small hole (\varnothing 2 mm) in the plug and pry it up with a pointed object or use special tool 531 03 01-91.

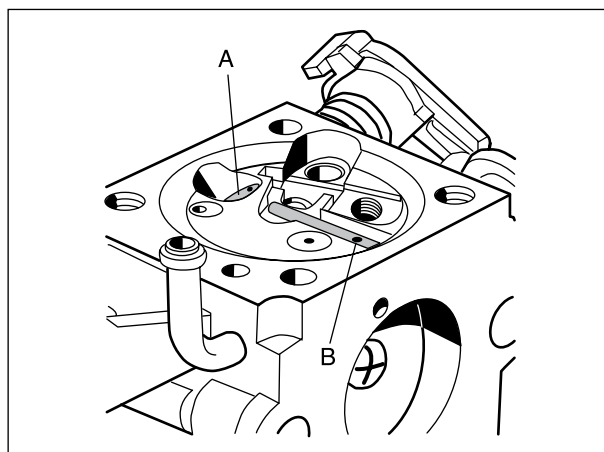

Remove the valves and springs. If these components are worn, idling is disrupted. Always replace the valves and springs at the same time.

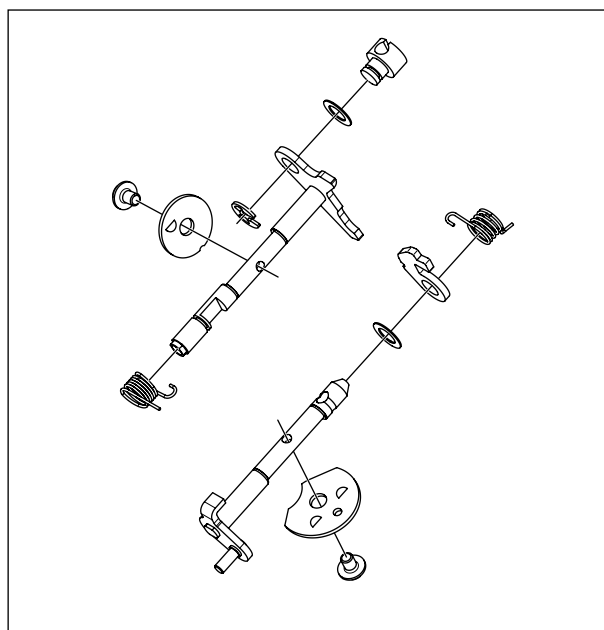

7.15 Assembling the carburetor

- Blow all channels in the carburetor compartment clean
- Mount a new plug (A).
Use a suitable punch to get a completely tight seal.
- Press in a new main jet (B).

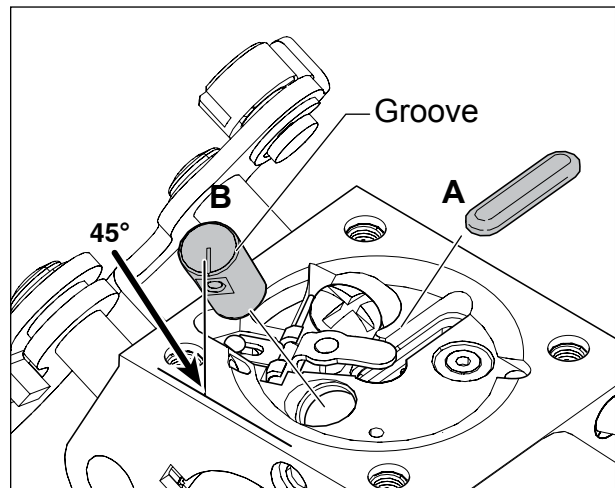

- Mount the valves and springs.

Tip!

Any numbers on the valves should be able to be read from the outside.
 Make sure valves has a perfekt seal by locking at the edge of the valve with tha carburetor backlit, a light from the choke side.
 Also make sure there are no clearence between axial stop (e-clip in this case) and the carburetor housing.

Replace the fuel screen if it is damaged or cannot be cleaned.
 Place the pump diaphragm closest to the carburetor housing. Then the gasket and cover and the other components in reverse order of removal.

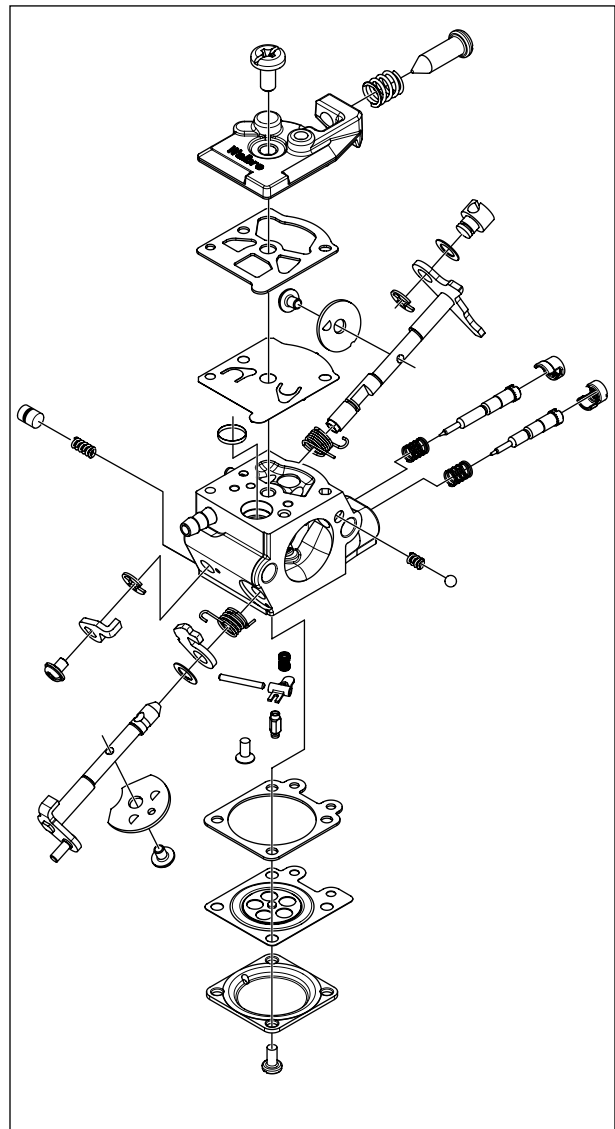

Attach the various parts of the measuring unit in the reverse order as set out for dismantling.

The lever arm height should be 0,66 mm \pm 0,16 mm under carburetor housing plane.

Too high setting = too much fuel.

Too low setting = too little fuel.

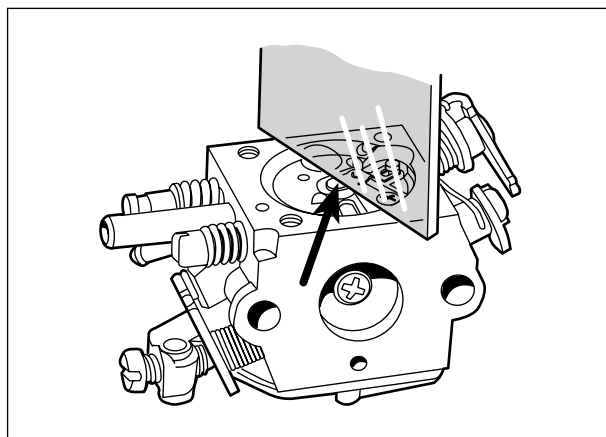

Connect pressure tester 531 03 06-23 to the fuel intake on the carburetor.

Pump up the pressure to 50 kPa.

Lower the carburetor in a vessel with petrol in order to discover any leaks more easily.

No leakage is permitted.

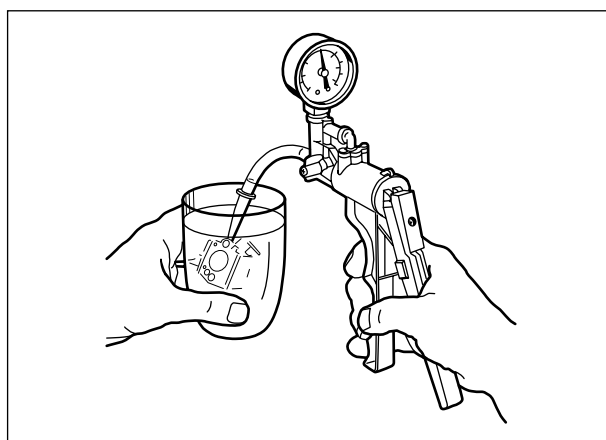

Place the gasket on the carburetor housing and then the control diaphragm.

Check that the air hole in the cover is open and screw the cover on.

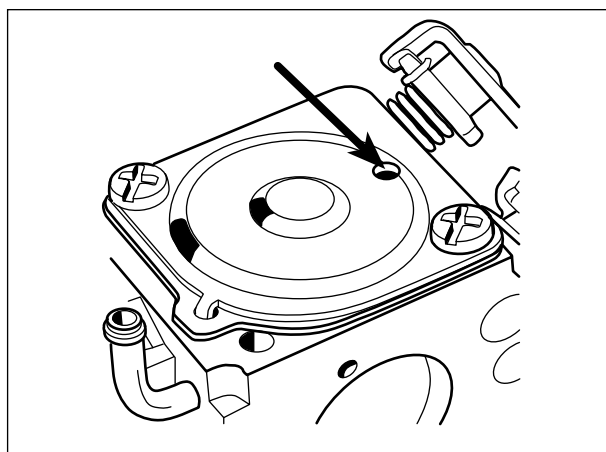

1. Secure the seal by using new gasket.
2. Connect the fuel pipe from the tank.
3. Slide in the carburetor between the air filter connection and the distance piece on the cylinder.
4. Tighten the carburetor screws and ensure that the seal is positioned correctly.



5. Connect the throttle cable on the carburetor with the help of flat nose pliers. Check that the cable sits correctly in the guide on the clutch housing (A) and that it sits correctly in the cut-out (B) of the insulator.
6. Connect the fuel pipe between the fuel pump and the carburetor.

Assemble the remaining parts in the reverse order as set out for disman

7.16 Carburetor settings



WARNING!
When testing the engine in connection with carburetor adjustment, the clutch and clutch cover must be mounted together with the shaft and bevel gear under all circumstances
Otherwise there is a risk of the clutch becoming loose resulting in serious personal injury.

Function

The carburetor has the task of supplying a combustible fuel/air mixture to the engine.

The amount of this mixture is controlled by the throttle.

The mixture's composition of fuel and air is controlled by means of the adjustable "H" and "L" needles.

The needles must be correctly adjusted in order for the engine to give maximum power at different speeds, run steadily while idling and to react quickly when accelerating.

The setting of the carburetor can vary a little depending on the humidity, temperature and air pressure.

- L = Low speed needle
- H = High speed needle
- T = Idle adjustment screw

- The fuel quantity in relation to the air flow permitted by the throttle opening is adjusted by the L and H jets. Turning the needles clockwise gives a leaner fuel mixture (less fuel) and turning them counter clockwise gives a richer fuel mixture (more fuel). A **leaner** mixture gives **higher** revs while a **richer** mixture gives **less** revs.
- The T-screw regulates the position of the throttle while the engine is idling. Turning the screw clockwise gives a higher idling speed while turning it counter clockwise gives a lower idling speed.

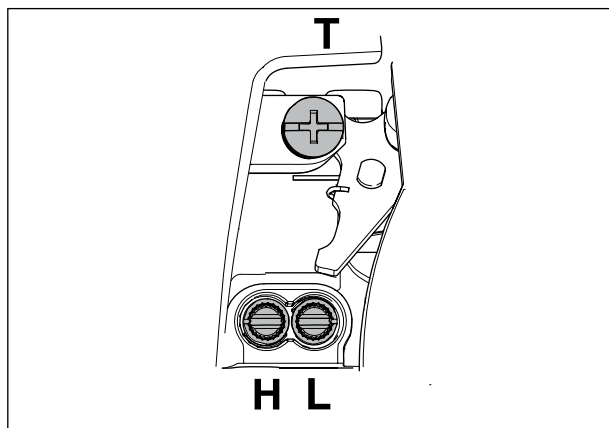
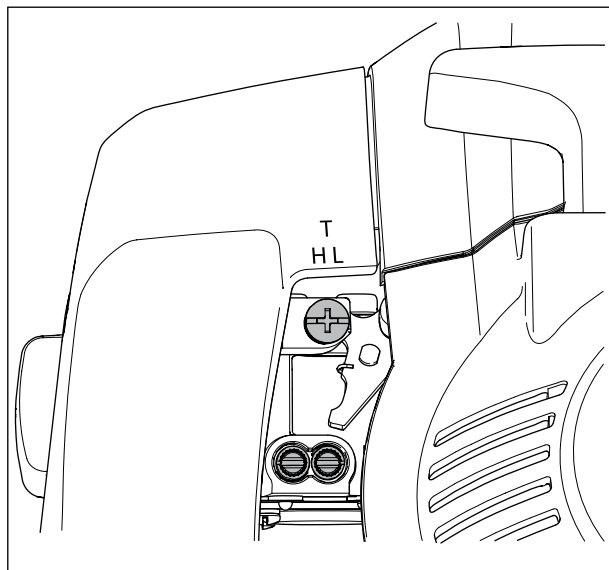
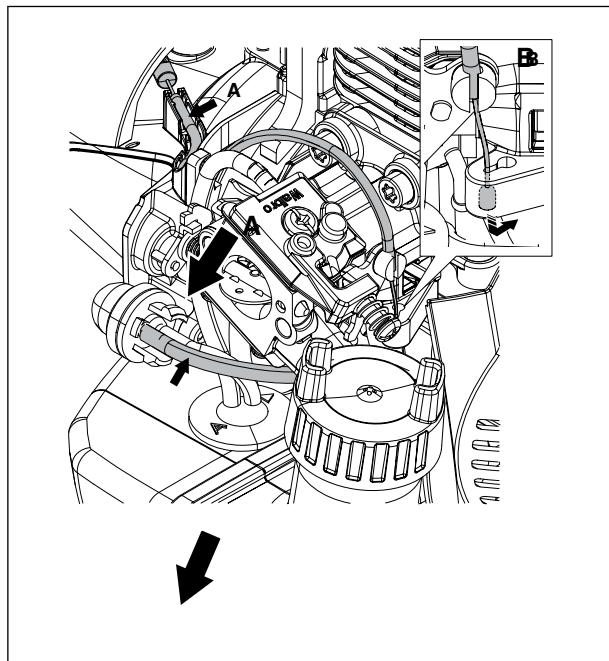

NOTE!

A revolution counter should always be used to achieve optimal setting.

Basic setting

The carburetor is set to its basic setting when test run at the factory. The basic setting is "richer" than the optimal setting and should be kept during the engine's first working hours. Thereafter the carburetor should be fine tuned.

The default setting is:

H = 2 1/2 revolution open

L = 2 1/2 revolution open

The following conditions apply to all carburetor settings in order to achieve the correct result:

- Defect-free spark plug with correct electrode gap.
- Defect-free air filter. Clean and correctly fitted.
- There should be no leaks between the cylinder and the distance piece and the carburetor and the insulator. Check the screws are tight.
- The fuel filter should be clean.
- The exhaust port (muffler and cylinder) should not be completely or partially clogged.
- The cutting attachment (blade or trimmer head) must be fitted. The cord length must be as standard (cut by the cutter on the splash guard).
- Correct fuel quality, minimum 89 octane.

Carefully screw in (clockwise) the L- and H-jets until they bottom. Now unscrew (counterclockwise) the jets to the default setting.

Use tool 530 03 55-60.

Fine adjustment

Fine adjustment of the carburetor should be carried out after the engine has been "run-in".

The engine must also be run warm for 4 minutes.

The carburetor setting must be carried out in two steps.

With a trimmer head

(Use Husqvarna T35 trimmer head with silent cord Ø 2.4 mm. The length of the trimmer cord will be adjusted by the knife on the original cutting attachment guard).

L-needle

Step 1: Turn the needle **clockwise** for the position providing maximum engine speed.

Step 2: Then turn the needle **counterclockwise** so that the speed drops by 700 rpm (from maximum speed (richer setting)).

H-needle

Step 1: Turn the needle **counterclockwise** the position where the engine speed become 9150 rpm.

Step 2: Turn the needle 1/4 of a turn **clockwise** (leaner setting).

NOTE!

Speed in excess of 11,000 rpm should be restricted by the ignition system and not recorded by the revolution counter.

Start the engine and check it responds quickly at full throttle, the idle speed is to be adjusted to 3000 rpm if necessary.

NOTE!

If the cutting attachment rotates when the engine is idling, the idle adjustment screw T should be turned counterclockwise until the cutting attachment stops.

7.17 Dismantling the centrifugal clutch, flywheel and ignition module

Remove the engine cover, clutch housing and spark plug. Screw the stopper (special tool A) into the plughole to fix the piston in place. Stopper 14 mm 514 24 39-01.

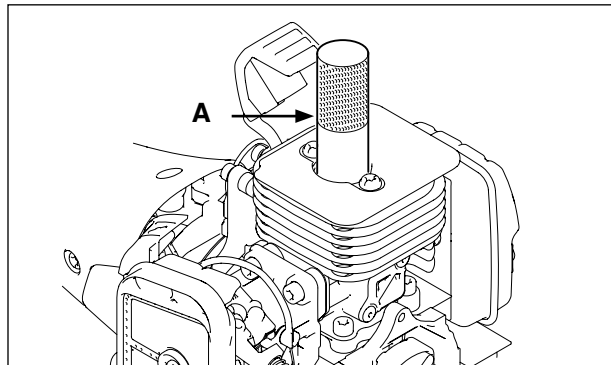

Remove the two screws holding the ignition module and take away the earth cable.

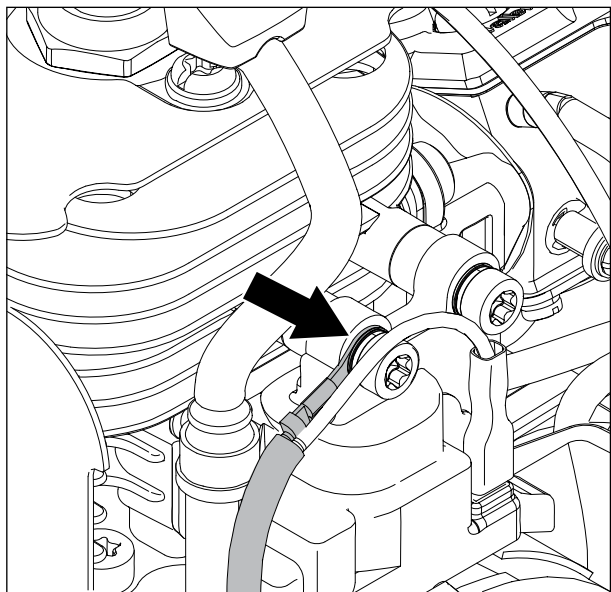

Take out the clutch bolts and waved washers, and remove the clutch. Clutch bolt width across flats (WAF) 14mm.

Waved washer thickness 0.5 mm (black)

Unscrew the bolts to the ignition module.

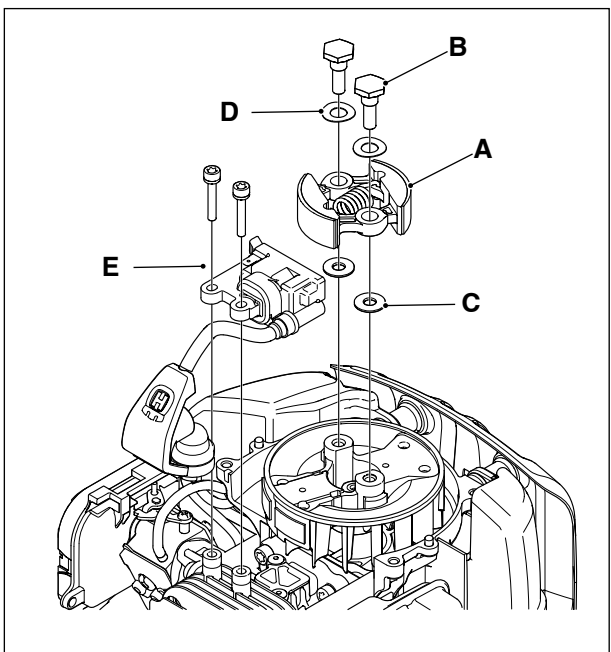

Fig 2	
A	Clutch
B	Clutch bolt
C	Washer
D	Waved washer
E	Ignition module

Take out the flywheel nut (A).

Rotor nut width across flats (WAF) M8 (WAF 12 mm)

NOTE!

Slowly turn the rotor counterclockwise, and after applying the stopper (special tool) lightly to the piston head, loosen the nut. The piston head could be damaged if force is applied too sharply when loosening the nut.

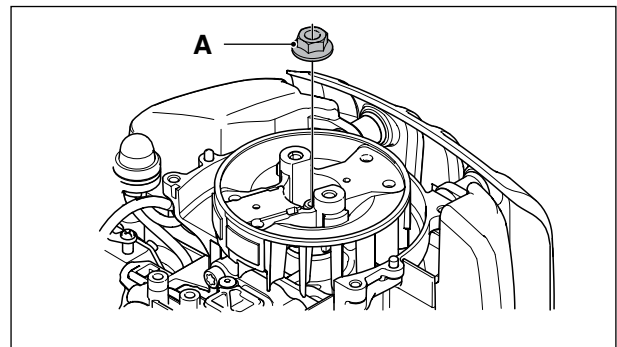

Using the puller, 510 13 89-01, remove the rotor from the crankshaft. The removal bolts on the puller differ according to the engine.

Removal bolt size M6 (WAF 10 mm)

NOTE!

Screw the removal bolt into the rotor until the thread is at least halfway in.

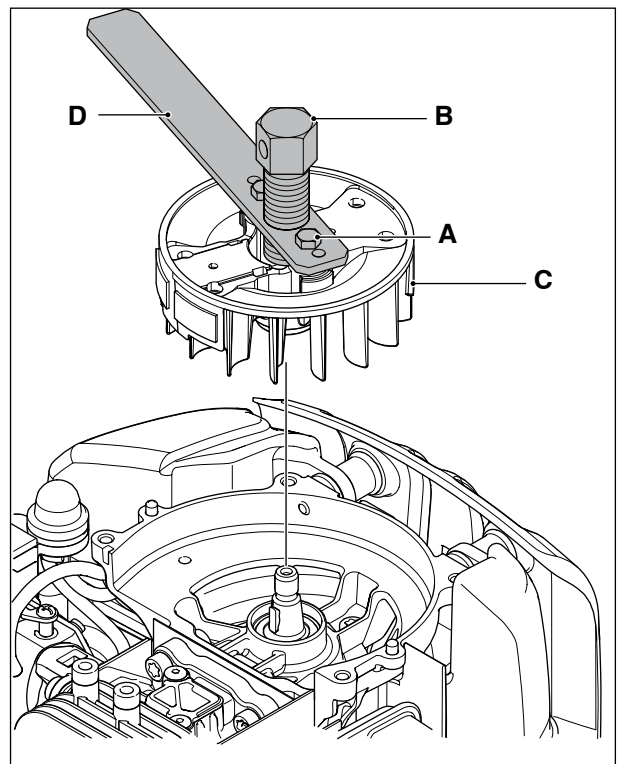

Fig 4

A	Removal bolt
B	Puller bolt
C	Rotor
D	Puller

7.18 Assembling the flywheel, ignition module and centrifugal clutch

1

When setting the key on the crankshaft, make sure the end face of the key is parallel with the crankshaft.

Fix the piston in place with the stopper (special tool) and tighten the rotor nut.

Torque 15 Nm

Fig 10	
A	fly wheel
B	Flywheel nut

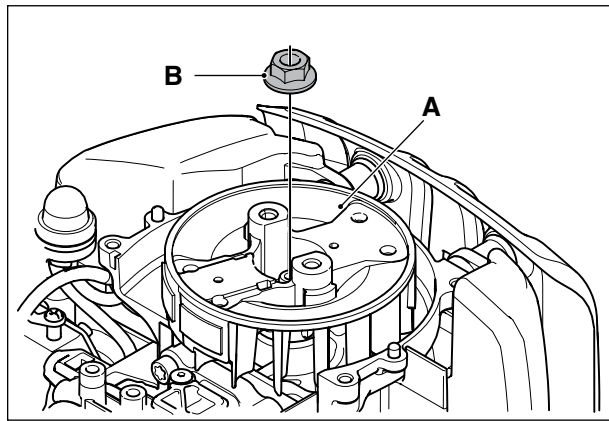

2

Before installing the clutch, check the lining for wear and replace with a new product if you find any uneven wear, peeling, etc.

Make sure the spring is intact and not cracked.

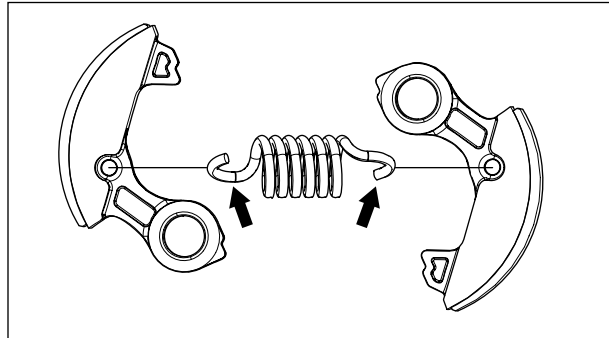
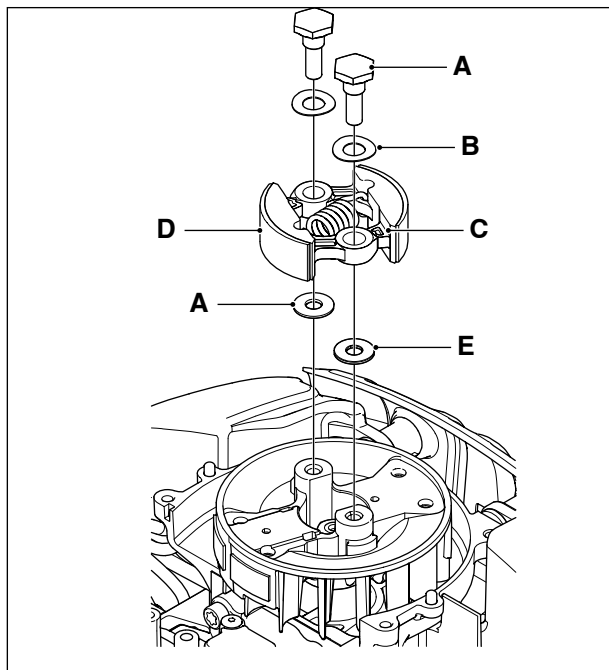

Fig 1	
A	Clutch bolt
B	Waved washer
C	Arrow mark
D	Clutch
E	Washer



NOTE!

If there are any uneven gaps or the spring is worn out or damaged between the spring coil when the clutch is in closed state, replace clutch shoe.

- Before installing, check for wear or rust on the greased parts of the clutch bolts, the washers and waved washers. Carefully remove any rust and replace any badly worn parts with new parts.
- Install the clutch on the rotor with the arrow mark on the clutch shoe facing the drum side.
- Apply molybdenum disulfide grease to the slide surface between the clutch bolts and clutch shoe.
- **Pay attention to the installation orientation of the waved washers.**
- Tighten the clutch bolts with the specified torque. See Fig. Torque: 8 Nm.

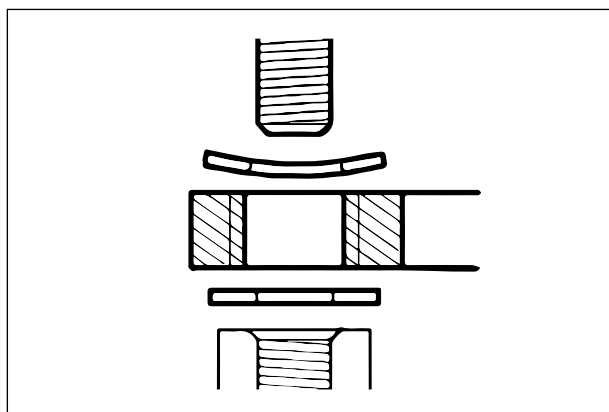

Place the ignition module in position and fit the screws. Do not tighten the screws.

Make sure the gap is: 0,3 mm

Tighten the bolts while pressing the ignition module the flywheel.

Assembly the sparkplug, all covers and the clutch covers with shaft.

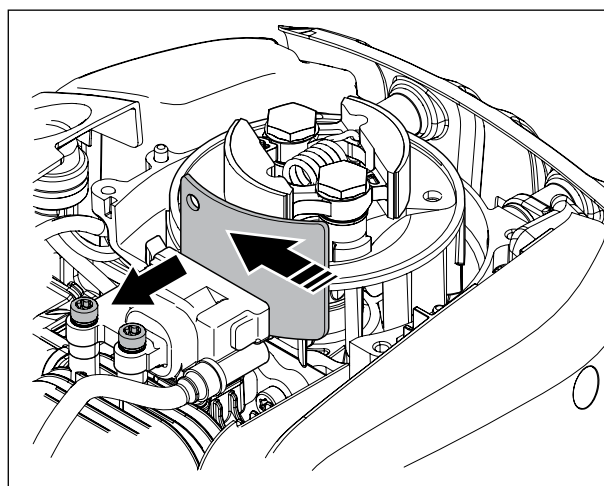

7.19 Dismantling the cylinder and piston

The cylinder and the piston are two of the components exposed to most strain in the engine. They must withstand, for example, high speeds, large temperature swings and high pressure. Moreover, they must be resistant to wear. Despite these tough working conditions, major piston and cylinder failure is relatively uncommon. The reasons for this include new coatings in the cylinder bore, new types of oil and grease and refined manufacturing techniques.

When servicing these components, cleanliness is of the utmost importance.

Before dismantling or other actions are performed on the cylinder block it is recommended that a compression test is made to easily determine whether any faults exist, for example, damaged piston rings or a damaged piston.

Dismantle the following parts:

All covers and starter

Muffler with gasket

Spark plug

Airfilter and filter holder

Carburattor and remove the insulator with the attached carburetor.

Heating plate on the top of the cylinder.

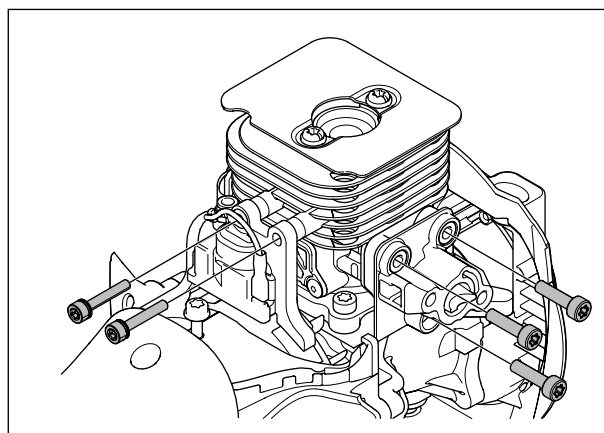

Remove the 4 bolts holding the cylinder against the crankcase.

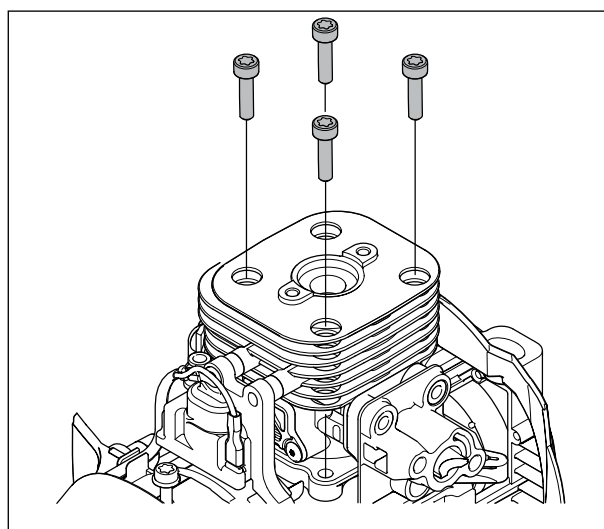

Pull the cylinder straight up without turning it. There is a risk that a piston ring may break.

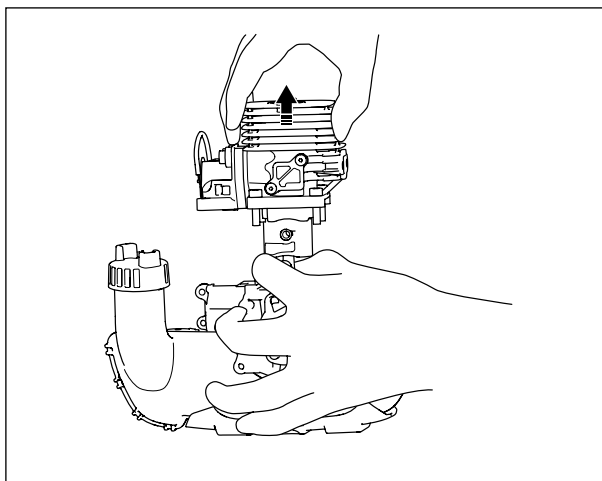

Remove the piston pin circlips.
Use small flat nose pliers and remove the piston pin circlips.

TIP!
Keep your thumb over the circlip to prevent it from flying out.

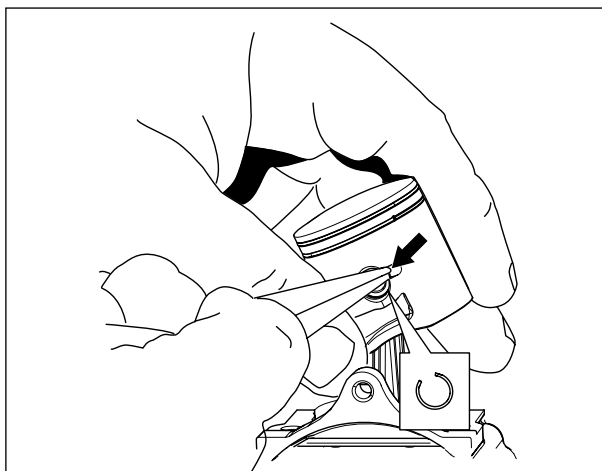

Press out the piston pin from the piston using the rod 513 18 12-01.

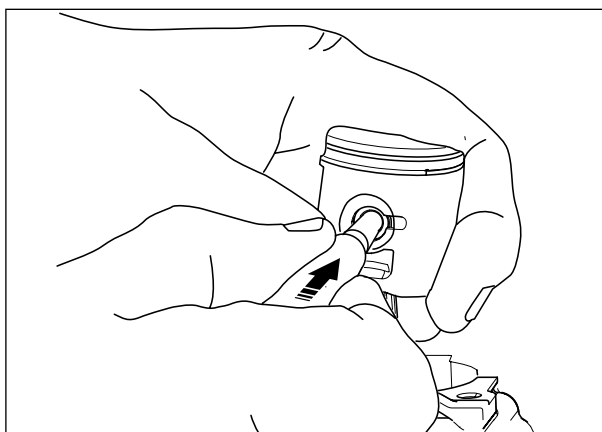

7.20 Cleaning, inspection

After dismantling, clean the individual components:

1. Scrape carbon deposits from the top of the piston.
2. Scrape carbon deposits from the cylinder's combustion chamber.
3. Scrape carbon deposits from the cylinder's exhaust port.

NOTE!

Scrape carefully off soot deposits using a not too sharp tool so as not to damage the soft aluminium parts.

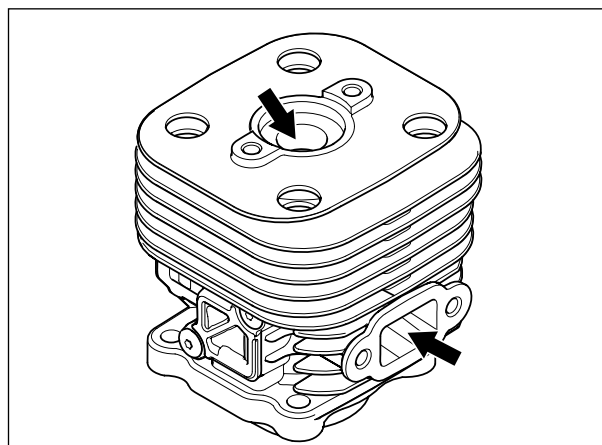

4. Wash all the components.
5. Inspect the different components for damage and wear.

Check the piston and cylinder for seizure damage and wear.

Also see the "Analysis and actions" section.

Check the piston ring for wear and possible breakage.

Also see the "Analysis and measures" section.

Check the piston pin.

- If it has blued, it must be replaced.
- If the piston moves too easily both the piston and the piston pin must be replaced.

Check the needle bearing. If it is discoloured or damaged, it must be replaced.

Check the circlips. If they exhibit cracks or are discoloured (caused by overheating), they must be replaced.

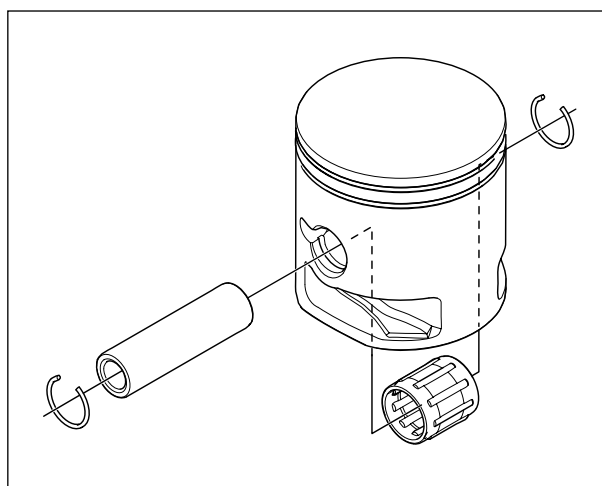

7.21 Analysis and actions

Experience tells us that piston or cylinder failure due to manufacturing errors are extremely rare.

The reason is usually due to other factors, which is evident from the following.

Note the reasons for the breakdown, repair the damage and take the actions required to prevent the same thing happening again.

Insufficient lubrication

The piston has small to medium size score marks usually in front of the exhaust port. In extreme cases heat development can be so great that material from the piston smears along the piston skirt and even in the cylinder bore.

Generally the piston ring is undamaged and moves freely in the ring groove

There can also be scores on the inlet side of the piston.

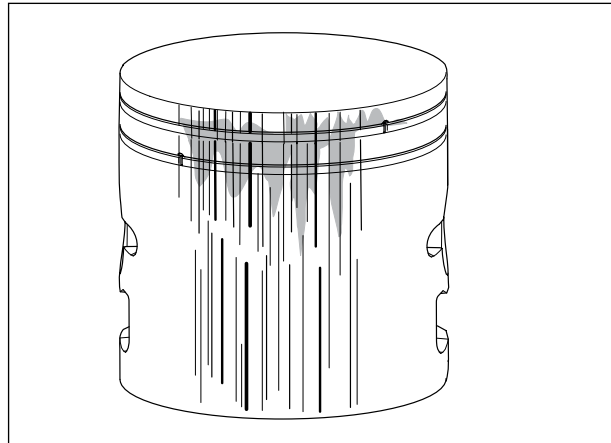

Cause:	Action:
Incorrect carburetor setting. Recommended max. speed exceeded.	Check and change the carburetor setting.
Incorrect oil mixture in the fuel.	Change the fuel.
Too low octane fuel	Change to a higher octane petrol.

The piston ring starts to stick or is completely stuck in its groove and has therefore not been able to seal against the cylinder wall, which has resulted in further, intensive temperature increases in the piston

Seizure scores along the entire piston skirt on the inlet and exhaust sides.

Cause:	Action
Incorrect oil mixture in the fuel.	Change to a fuel with the correct oil mixture.
Too low octane fuel.	Change to a higher octane petrol.
Air leaks	Replace damaged parts.
Cracked fuel hose.	
Leaking inlet gaskets.	
Cracked insulator or inlet manifold.	
Air leakage in engine body.	Replace leaking gaskets and shaft seals.
Leaking crankshaft seals.	
Leaking cylinder and crankcase gaskets.	
Poor maintenance.	Clean the cooling fins and air intake.
Dirty cooling fins on the cylinder.	
Blocked air intake on the starter.	
Blocked spark arrestor mesh in the muffler.	Clean or replace the spark arrestor mesh.

For the best results we recommend Husqvarna two-stroke oil or ready-mixed fuel that is specially developed for air-cooled two-stroke engines.

Mixing ratio: 1:50 (2%).

If Husqvarna two-stroke oil is not available another good quality two-stroke oil can be used.

Mixing ratio: 1:33 (3%) or 1:25 (4%).

Piston scoring caused by heavy carbon deposits

Too heavy carbon depositing can cause damage similar to that caused by insufficient lubrication. However, the piston skirt has a darker colour caused by the hot combustion gases that are blown past the piston.

This type of piston damage starts at the exhaust port where carbon deposits can become loose and get trapped between the piston and the cylinder wall.

Typical for this type of piston damage is brown or black discoloration of the piston skirt.

Cause:	Action:
Wrong type of two-stroke oil or petrol.	Change the fuel and/or oil.
Incorrect oil mixture in the petrol.	Change to a fuel with the correct oil mixture.
Incorrect carburetor setting.	Correct the carburetor setting

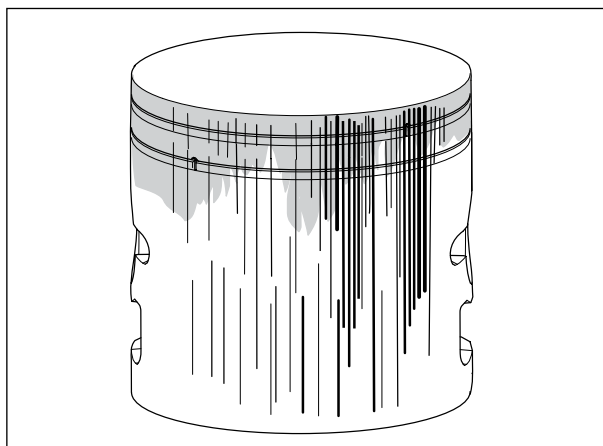

Piston damage caused by a too high engine speed.

Typical damage associated with a too high engine speed includes broken piston rings, broken circlip on the piston pin, faulty bearings or that the guide pin for the piston ring has become loose.

Piston ring breakage

A too "lean" carburetor setting results in a too high speed and a high piston temperature. If the piston temperature rises above the normal working temperature the piston ring can seize in its groove, consequently it will not sit deep enough in its groove. The edges of the piston ring can then hit the top edge of the exhaust port and be smashed and also cause piston damage.

A too high engine speed can also cause rapid wear to the piston ring and play in the piston ring groove primarily in front of the exhaust port. The ring is weakened by the wear and can be caught in the port causing serious piston damage.

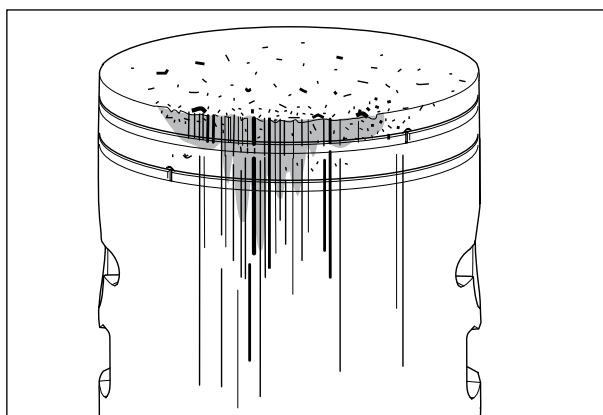

Piston ring guide pin vibrated loose

A too high engine speed can cause the ends of the piston ring to hammer against the guide pin when the piston ring moves in its groove. The intensive hammering can drive out the pin through the top of the piston causing serious damage also to the cylinder.

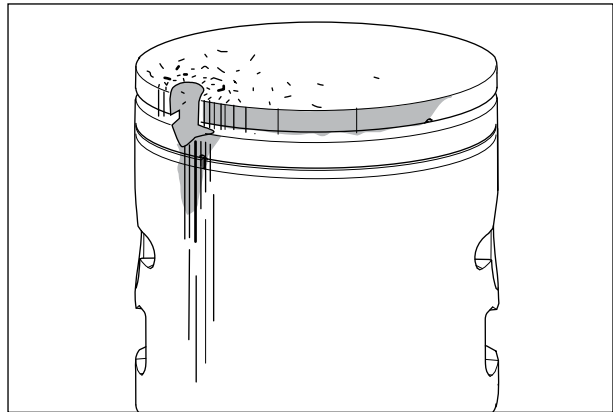

Damage caused by gudgeon pin circlips

A too high engine speed can cause the gudgeon pin circlips to vibrate. The circlips are drawn out of their grooves due to the vibrations, which in turn reduces the circlips' tensioning power. The rings can then become loose and damage the piston.

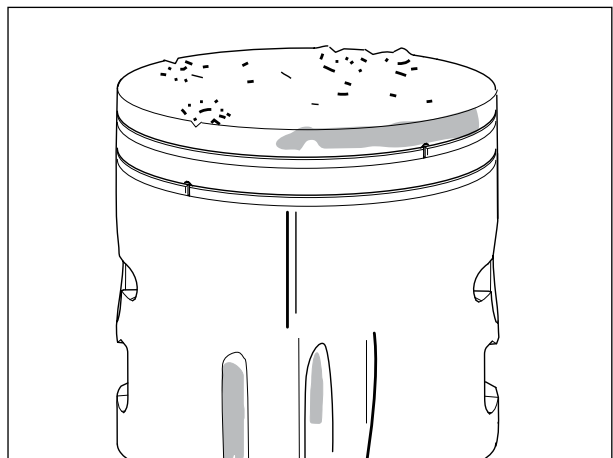

Bearing failure

Failure of the crankshaft bearing or on the connecting rod bearing is usually caused by a too high engine speed, resulting in the bearing being overloaded or overheating. This in turn can cause the bearing rollers or ball to glide instead of rotate, which can cause the roller or ball retainer to break.

The broken debris can be trapped between the piston and cylinder wall, damaging the piston skirt.

Debris can also pass up through the cylinder's transfer channels and cause damage to the top and sides of the piston as well as to the cylinder's combustion chamber.



Foreign objects

Everything other than clean air and pure fuel that enters the engine's inlet port causes some type of abnormal wear or damage to the cylinder and piston.

This type of increased wear shows on the piston's inlet side starting at the lower edge of the piston skirt.

The damage is caused by badly filtered air that passes through the carburetor and into the engine

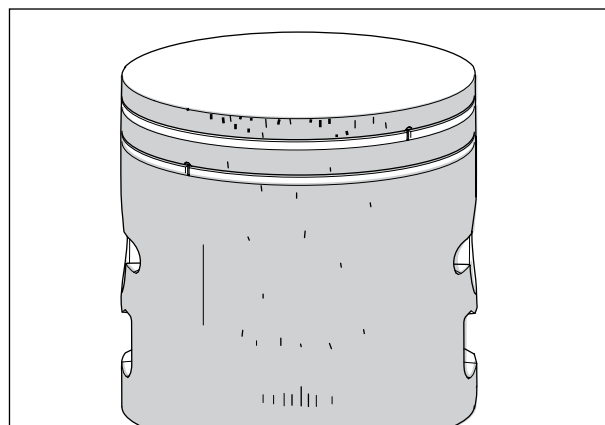

Inlet side.

Particles of dust and dirt from carbon-like deposits on the top of the piston and in the piston ring groove. The piston ring sits firmly in the groove. Piston material has been worn away.

The lower part of the piston skirt is thinner on the inlet side than on the exhaust side.

Cause:	Action:
Faulty air filter. Small dust particles pass through the filter.	Replace to a correct and a new filter.
The filter is worn out due to too much cleaning, whereby small holes have appeared in the material.	Check the filter carefully for holes and damage after cleaning. Replace the filter if necessary.
Unsuitable filter maintenance, such as wrong method or wrong cleaning agent. Flock material becomes loose and holes appear.	Clean more carefully and use the right cleaning agent (such as tepid soapy water). Change the filter.
Air filter incorrectly fitted.	Fit the filter correctly.
Air filter damaged or missing	fit a new air filter

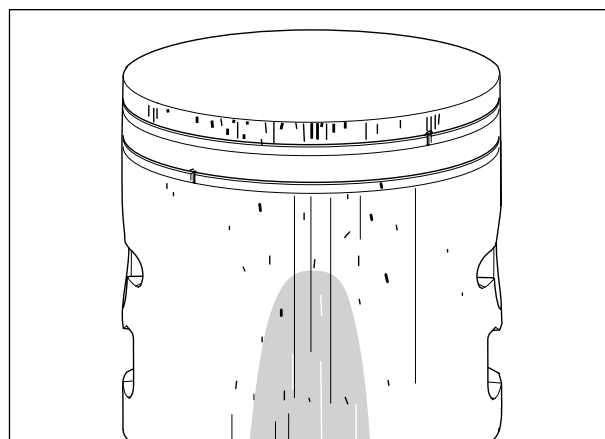

Larger, softer particles that penetrate into the engine cause damage to the piston skirt under the piston ring as the illustration shows.

Cause:	Action:
Air filter incorrectly fitted.	Fit the air filter correctly.
Air filter damaged or missing.	Fit a new air filter.

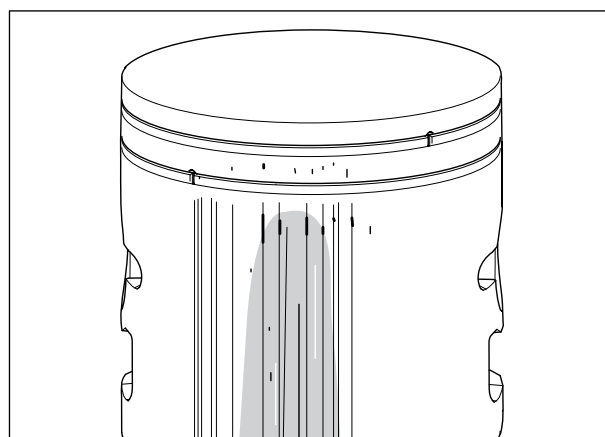

Larger, harder particles that enter the engine cause serious damage to the underside of the piston skirt.

Cause:	Action:
Air filter damaged or missing.	Fit a new air filter.
Parts from the carburetor or intake system have come loose and entered the engine.	Regular service and inspection.

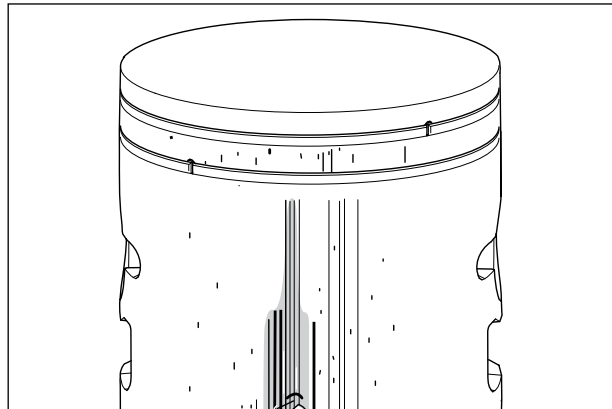

Service tips

Defect:	Action:
Broken cooling fins, damaged threads or sheared bolts by the exhaust port.	In severe cases – replace the cylinder. Repair the threads using Heli-Coil.
Seizure marks in the cylinder bore (especially by the exhaust port).	Polish the damaged area using a fine grade emery cloth so that the coating of aluminium disappears. With deep seizure score marks the piston and cylinder should be replaced.
Surface coating in the cylinder bore worn out (primarily at the top of the cylinder).	Replace the cylinder and piston.
The piston shows signs of seizure score marks	Carefully polish the damaged area using a fine file of fine grade emery cloth. Before the piston is refitted the cylinder should be polished as above. With deep score marks the piston and cylinder should be replaced.
Piston ring burnt in its groove.	Carefully loosen the piston rings and clean the groove well before refitting. Carbon deposits in the groove impair the important heat transfer between the piston and cylinder.
	NOTE! Be careful with the lower edge of the piston ring groove. If this is damaged, or if carbon deposits remain, the compression pressure can leak through.
	Check the wear on the piston ring by placing it in the lower part of the cylinder.
Bolts much too tight in the aluminium material.	Position a suitable punch on the bolt head and give a few sharp knocks with a hammer. If the bolt still does not loosen, repeat the procedure.

Wear tolerances

Cylinder bore

When the surface coating is worn and aluminium appears

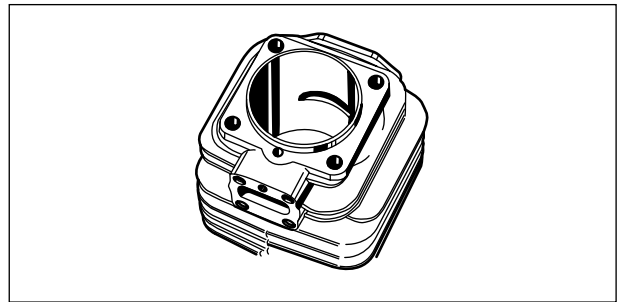

Piston ring gap

Max. 0,5 mm with the piston ring inserted in the lower part of the cylinder.

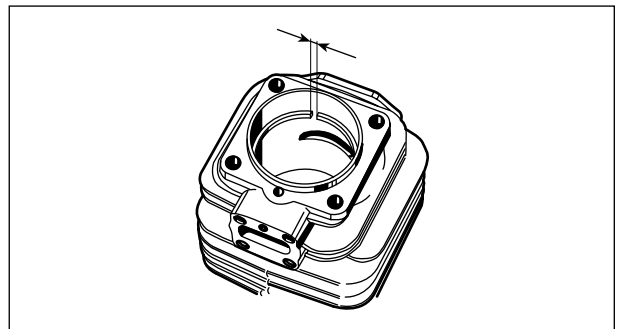

Piston ring groove

Max. 1,1 mm. Clean the groove before checking the measurement.

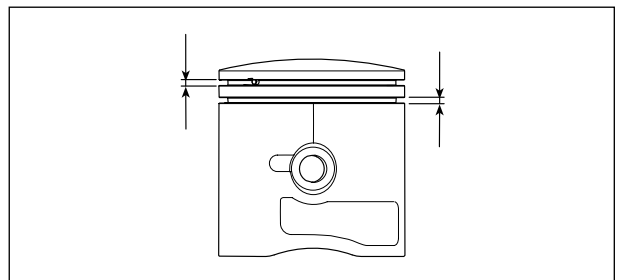

Piston ring play

Max. 0,1 mm. Clean the groove before checking the measurement.

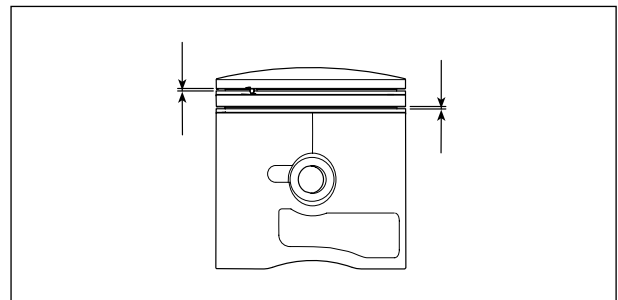

7.22 Assembling the piston and cylinder

Clean the crankcase

Fit the piston on the connecting rod so that the arrow on the piston points towards the exhaust port. Lubricate the piston pin's needle bearing with a few drops of engine oil.

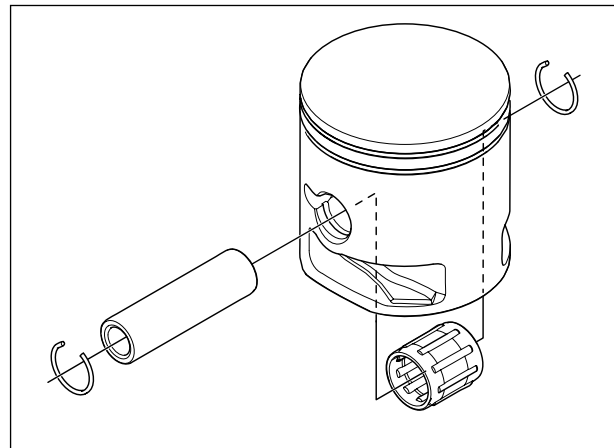

NOTE!

Place a rag in the crankcase opening to prevent the circlip from falling into the crankcase in case it should fly out. Check that the circlips are correctly fitted into the grooves by turning the clips with flat nosed pliers

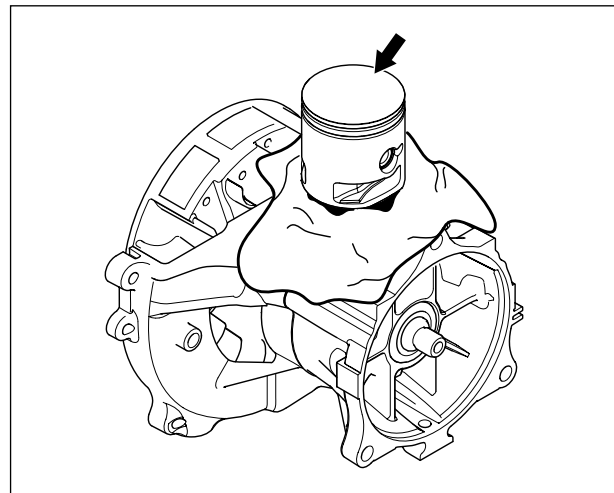

Check the gasket halves is undamaged and is positioned correctly on the crankcase.

Lubricate the piston and the piston ring using a few drops of oil and carefully slide the cylinder over the piston.

NOTE!

Do not turn the cylinder, as the piston rings can easily be broken.
Tighten the 4 screws diagonally crosswise.

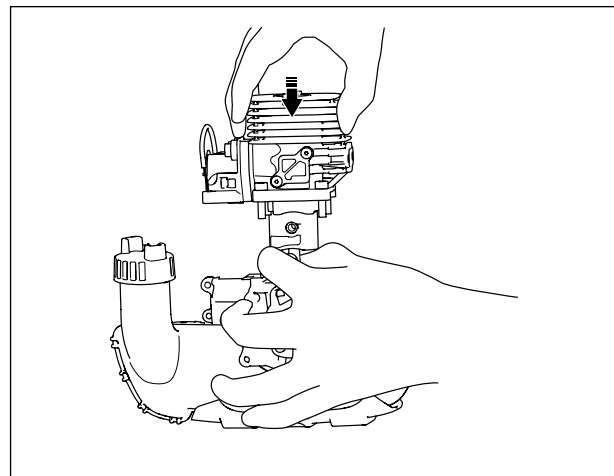

Assemble the remaining parts:

Intake system

Muffler

Carburetor

See specific instructions

7.23 Dismantling crankshaft and crankcase

The task of the crankshaft is to transform the reciprocating motion of the piston to rotation. This requires a stable design withstanding immense pressure and rotational and bending strain, as well as high rotational speed. In addition the connecting rod is exposed to large acceleration and retardation forces as it moves between the top and bottom dead centres. This puts special demands on the bearings that must withstand quick changes in load. Moreover, the bearing's roller retainer must also cope with high temperatures and friction. It is therefore extremely important when servicing to check the roller retainer for cracks, wear and discolouration caused by overheating.

The crankshaft is journalled in the crankcase on heavy-duty ball bearings. In addition to the journaling point for the crankshaft, the crankcase acts as a scavenging pump for the fuel/air mixture when this is "sucked" from the carburetor and is forced into the cylinder's combustion chamber. The crankcase must be perfectly sealed so as not to affect this pump function. There cannot be any leakage from the crankshaft, between the crankcase halves or between the crankcase and the cylinder.

Always replace the oil seal and gaskets when servicing the crankcase.

Dismantling

Dismantle all components so that only the crankcase and crankshaft remain.

See the respective sections for detailed information if necessary.

Remove the key from the crank shaft using a tool.

Remove the crankshaft out of the crankcase.

Remove the bearings and oil seal (press fit).

Remove the gasket between crankcase halves and residue the base of the cylinder and crankcase.

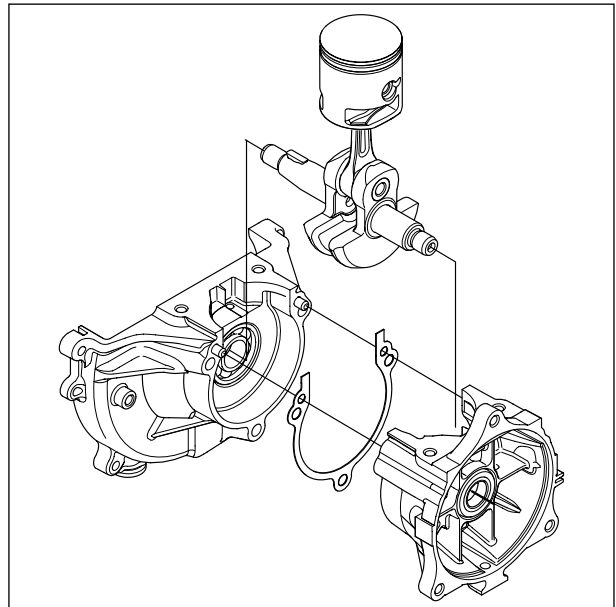

Inspecting the crankshaft

The crankshaft cannot be reconditioned but must be replaced if it is worn or damaged.

Inspect the large end of the connecting rod. If seizure marks, discolouration on the sides or damaged needle holders are found the crankshaft must be replaced.

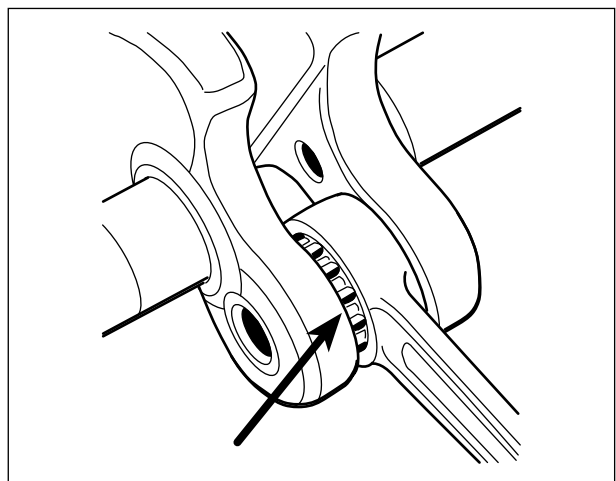

Inspect the small end of the connecting rod.
If seizure marks or discolouration are found in the bearing track the crankshaft must be replaced.

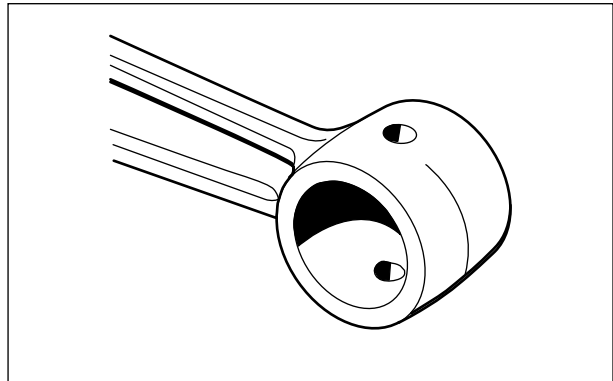

Check the crank bearing. The connecting rod shall not have any radial play (up and down).
It should, however, have axial play, in order to ensure good lubrication of the crank bearing among other things.

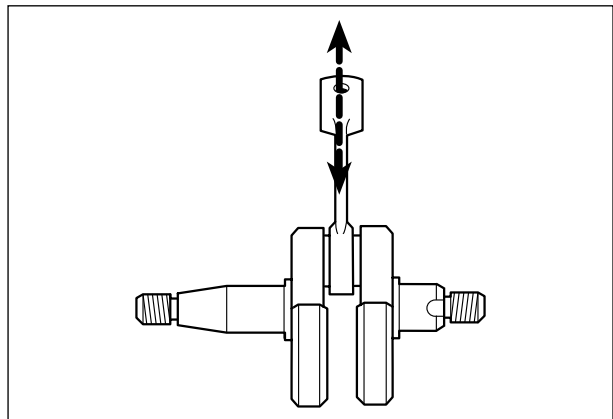

Check for wear and damage on the crankshaft's bearing and on oil seal.

Bearing and oil seal should always be replaced by a new bearing and oil seal if it is damaged or worn out.

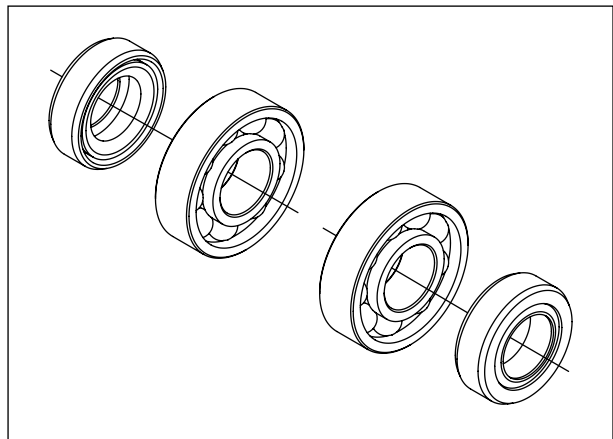

7.24 Assembling the crankshaft and crankcase

Check the crankshaft as set out in the section "Inspecting the crankshaft".

Fit the new bearing in the crankcase using a press tool.

During press fit of the bearing don't push the inner bearing to fit

Assemble the piston on the crankshaft.

Lubricate the big-end bearing with a few drops of engine oil and position the crankshaft in the crankcase. Use new gasket.

Insert the crankshaft into the crankcase bearing. Flywheel side might be tight. Use a press tool. don't use a hammer. During this process hold the inner bearing from the back side by a solid piece. Assemble the crankcase by using a new gasket and cut off the ends of the gasket.

Assemble the oil seal into the crankcase using a press tool. And do not damage the oil seal lip during this process.

Assemble the cylinder on the piston. Use a new gasket.

Install the key onto the crankshaft. Upper surface of the key should be in parallel to the crankshaft axis

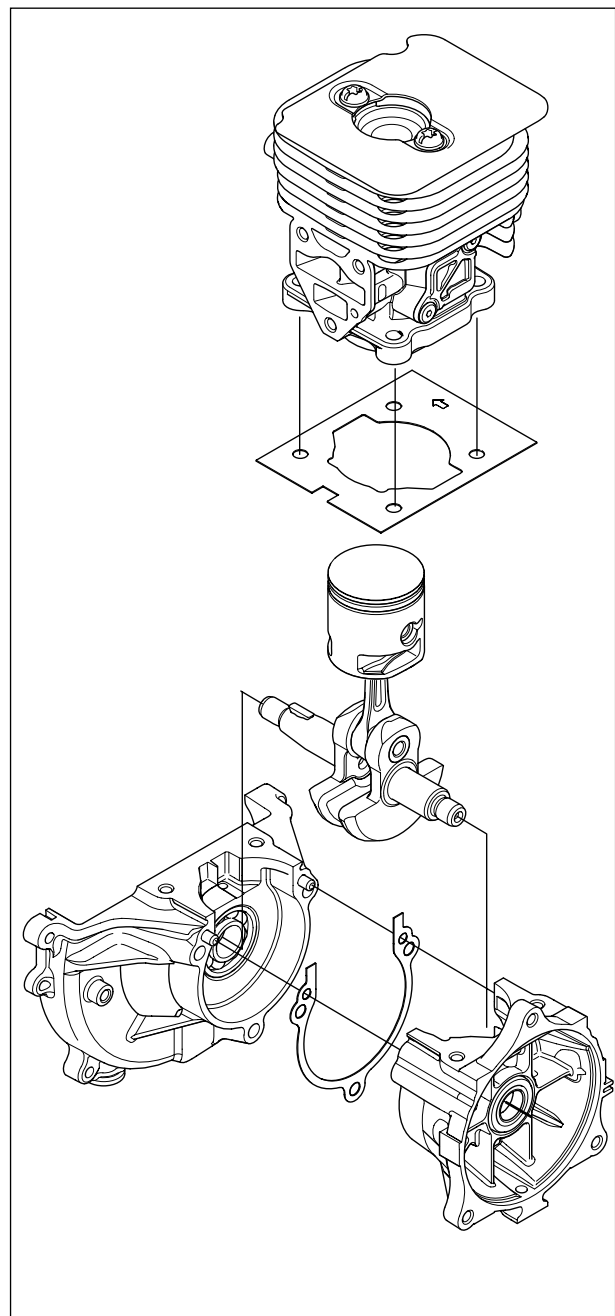
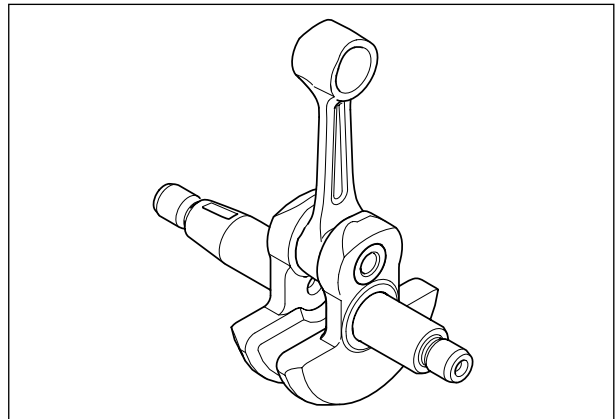

7.25 Replacing the clutch drum and drive shaft

The centrifugal clutch has the task of transferring the power from the engine to the cutting equipment's drive shaft. As the name implies, it works according to a centrifugal principle.

This means the clutch's friction shoes are thrown outwards towards the clutch drum at a certain engine speed. When the friction against the drum is sufficiently great it drives the drive shaft at the same speed as the engine.

Some slipping occurs between the clutch and the clutch drum when accelerating as well as in the reversed situation when the cutting equipment jams. Thereby preventing abnormal load changes on the crankshaft.

The engagement speed has been carefully tested so that the engine can idle without the cutting equipment's drive shaft rotating.

7.26 Dismantling and assembling the clutch drum and drive shaft

See removal instruction in chapter 7.5.

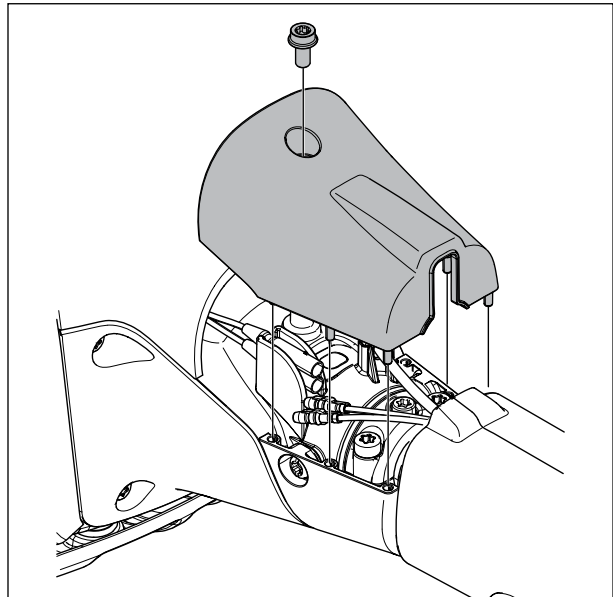

Remove the screw (A) and screw (B) that holding the clamp connection for the shaft.

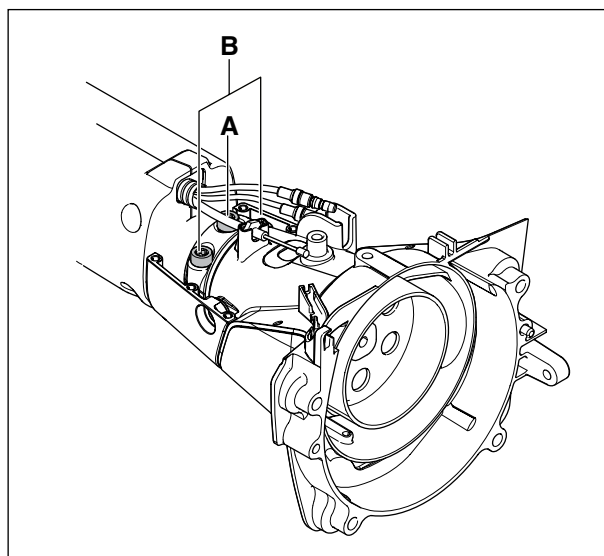

Remove the two screws holding the clutch housing cover.

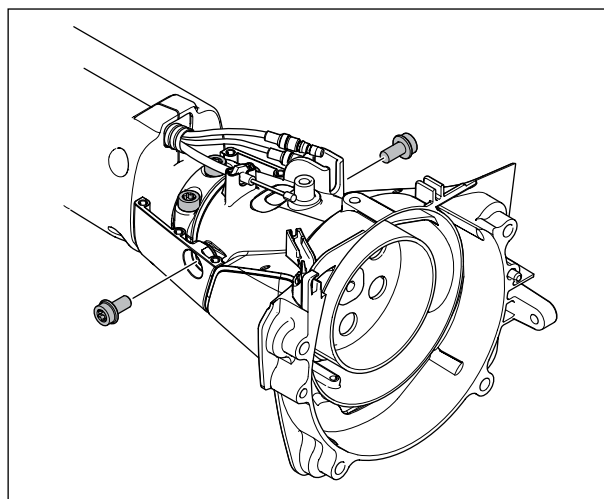

Pull apart the shaft from the clutch housing.

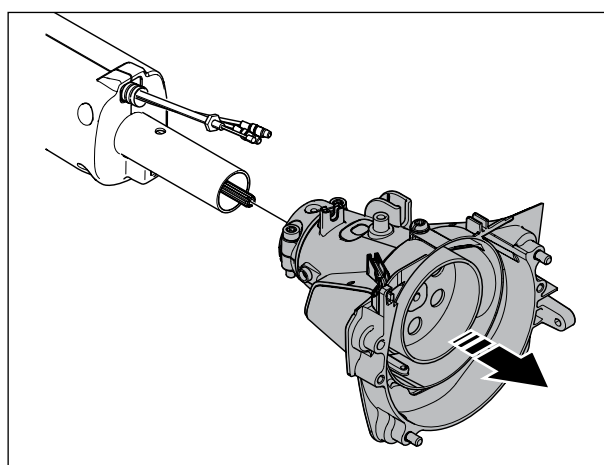

Remove the upper and lower clamp.
Remove the anti vibrations element

Note!
replace the antivibration element if it is damaged or cracked.

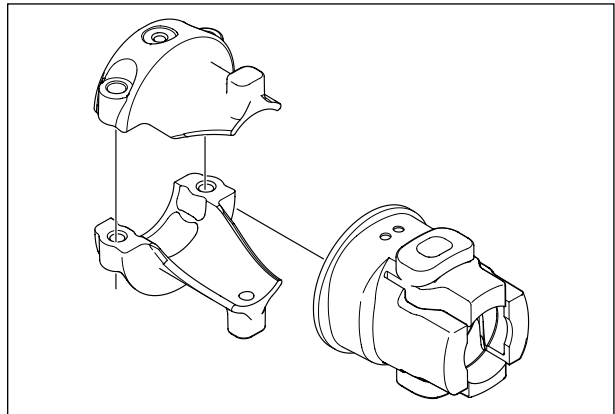

Remove the small circlip from around the shaft on the clutch drum using suitable circlip pliers. 515 41 95-01

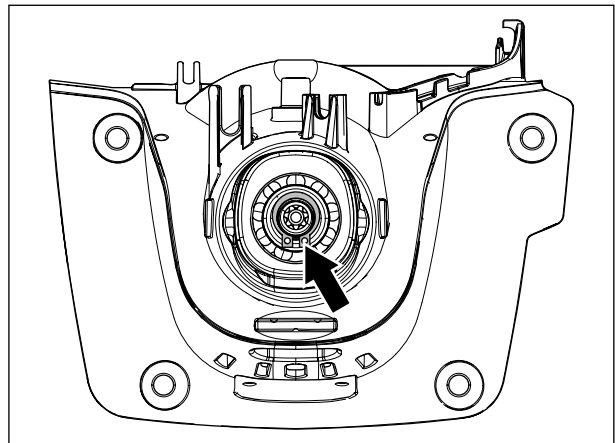

Dismantle the clutch drum by using a special tool, 581 44 10-01.

Dismantle the ring using a circlip pliers.
Dismantle the bearing using an appropriate punch and hammer.

Assemble in the reverse order as set out for dismantling. Use a press tool for installing bearing and clutch drum.

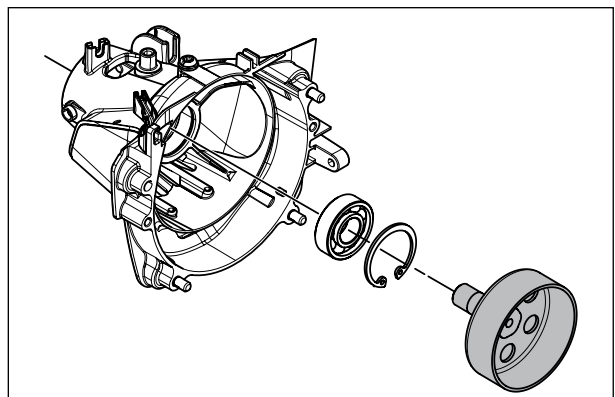

Note!
Always use new bearings, if the clutch drum is removed.

7.27 Dismantling the saw head (PT5S)

Dismantle the saw head from the telescopic tube. Loosen the screw (C). Unscrew the locating screw (D) as much as required in order to twist the saw head and detach it from the telescopic tube. Remove the nut (A) and lift off the cover (B), and chain and bar.

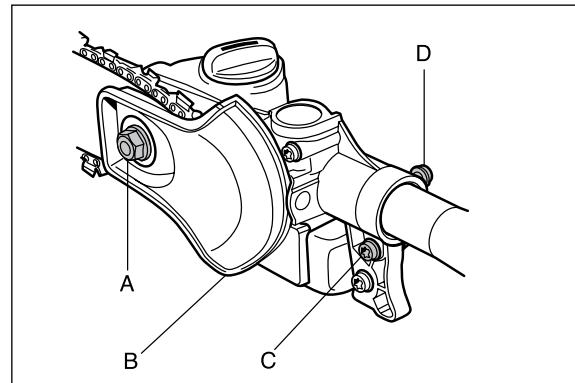

Remove the nut and washers. Make sure to counterhold on the inner washer when removing nut. Remove the drive spur.

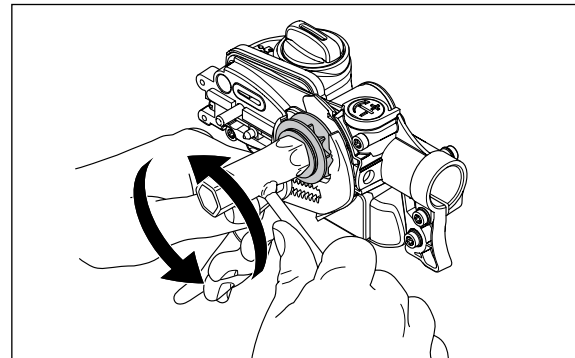

Remove the screw (E) and the plastic cover (F) using a screwdriver.

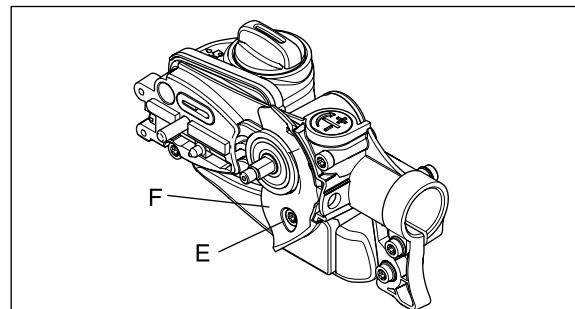

Remove the three screws holding the oil tank in place.

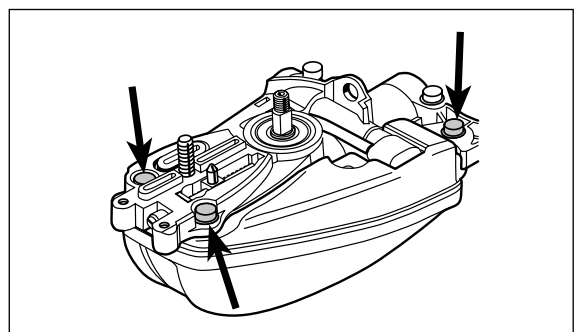

Carefully lift off the oil tank straight up from the oil pump to prevent the oil filter (G) from sliding off the hose and falling into the tank.

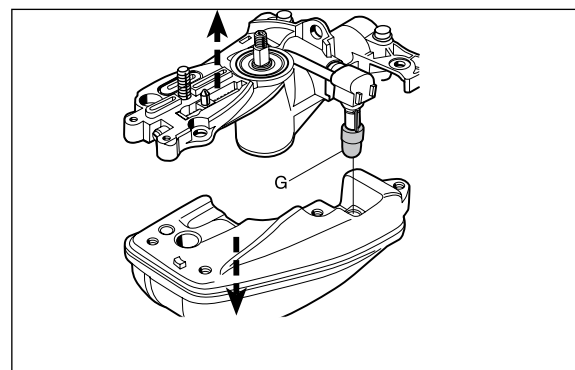

Remove the hose from the connection at the bar mounting using a screwdriver. Begin at the front end.
Remove the pump unit from the drive axle.

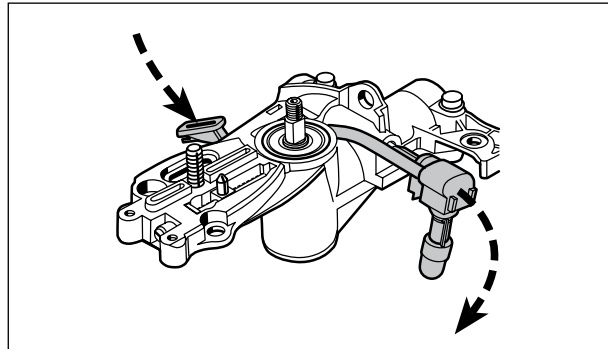

Remove the screw (H) completely.
Press the pump axle out through the saw housing.

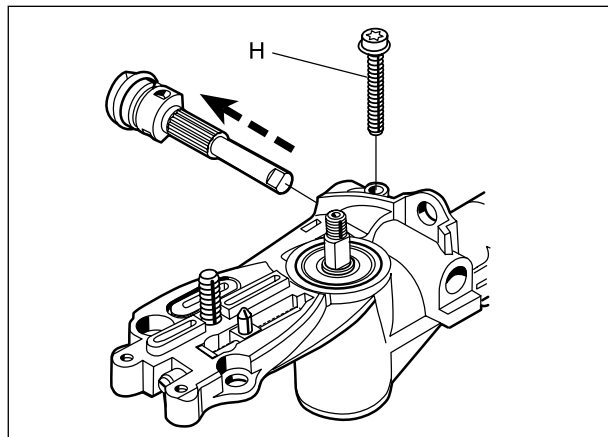

Remove the large circlip holding the ball bearing for the pinion using a couple of pliers.
Heat the saw housing, approximately 110° C, using a hot air gun and knock it gently against a wooden block so that the pinion with the ball bearing falls out.

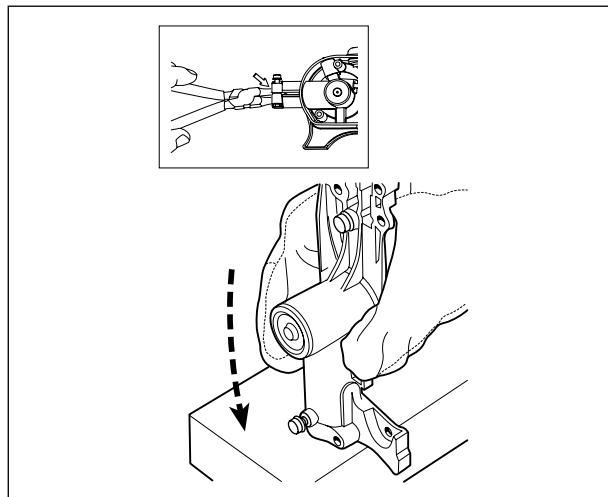

Remove the drive shaft (A) by first removing the plug (B) using a screw driver in the gap an then by using remaining heat knock it gently against a wooden block. Alternately insert the mandrel in both cut-outs in the gear housing to press the plug straight out to prevent it from getting stuck sideways.

Note!
The small circlip holding the pinion against the shaft does not have to be removed.

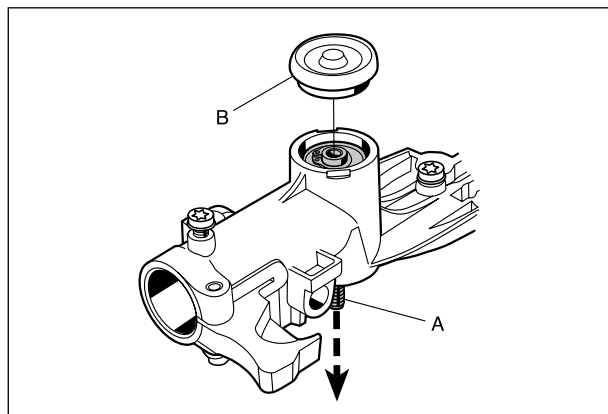

7.28 Assembling the saw head (PT5S)

Clean and inspect all components. Replace any worn or defective components.
 Clean the tank venting filter (A) using compressed air.
 Clean the oil filter (B) and rinse the inside of the oil tank using thinner if required.

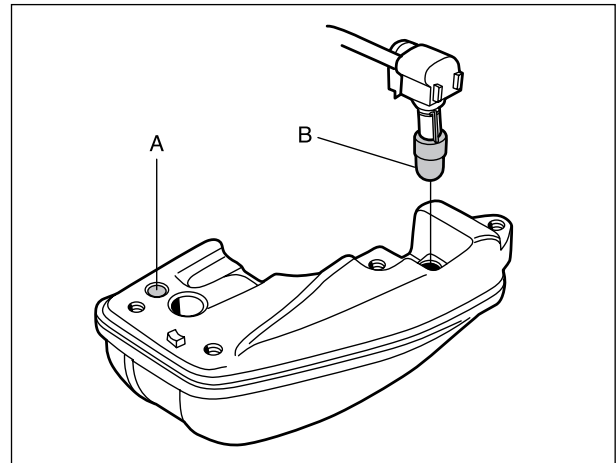

Assemble the different components in the reverse order as set out for dismantling.

Note: Always use Grease with art. no: 579 06 49-01 on the wheels (B,H) and in the gear.

Assembly sequence:

1. Drive shaft

Press the ball bearing (A) on the shaft (B).
 Fit the circlip (C).
 Heat the saw body with a hot air gun, approximately 110°C.
 Fit the ball bearing (D) using a suitable mandrel.
 Lubricate the sprocket with gear housing grease and push the shaft into bearing seating.
 Fit the cover (E) using a plastic hammer.

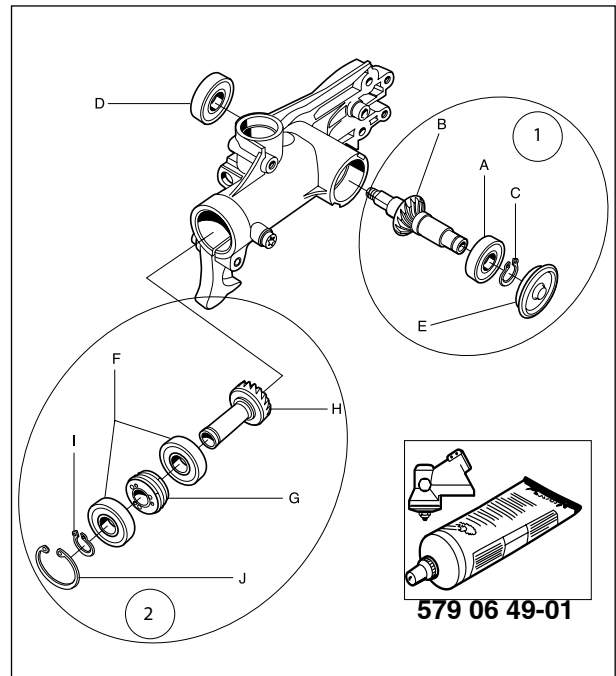

2. Pinion

Press the ball bearings (F) and the pump drive (G) onto pinion (H). Use a suitable mandrel.
 Fit the circlip (I).
 Lubricate the gear with gear housing grease and insert the pinion in the bearing seating while the saw housing is still hot.
 Make sure that the shaft (B) and the pinion (H) connect to each other and rotate easily.
 Fit the circlip (J).

3. Oil pump

Check that the O-ring (A) is not damaged. Fit a new one if required.
 Push the oil pump (B) into the pump housing. You can only fit the pump in a certain angle.
 Fit the screw (C).
 Press the oil pipe (D) into place and make sure that the connection (E) at the bar mounting is correct and seals against the bar as intended.

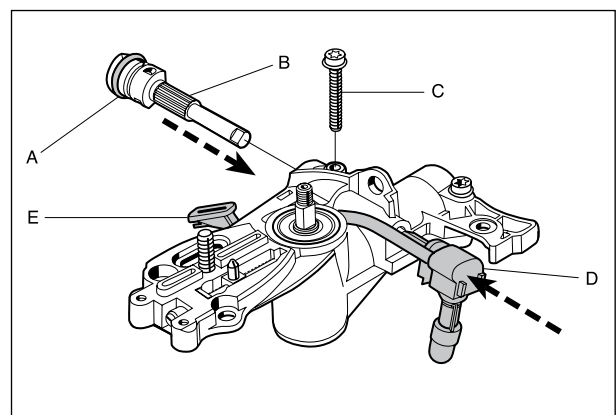

Put the oil tank and the saw housing together. Do not forget the oil filter (A). Make sure it is clean and not damaged. Make sure the tank venting filter (B) is clean. Tighten the three screws.

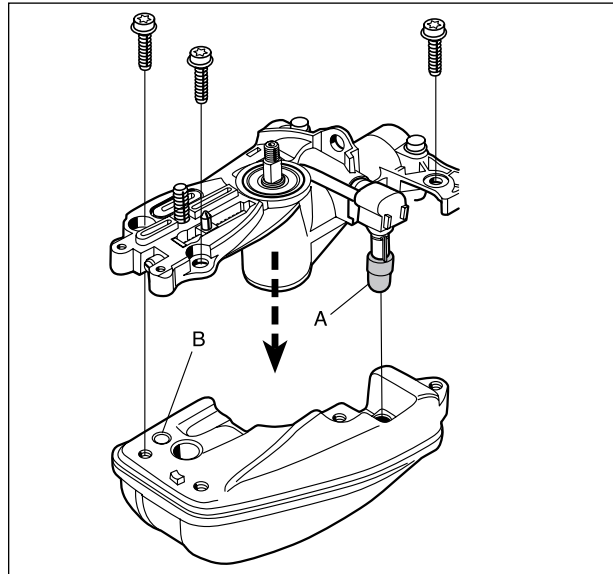

Assembly the plastic cover and tighten the screw. Assembly the washer, spur and the spring washers. Make sure they are assembly in correct order, see figure.

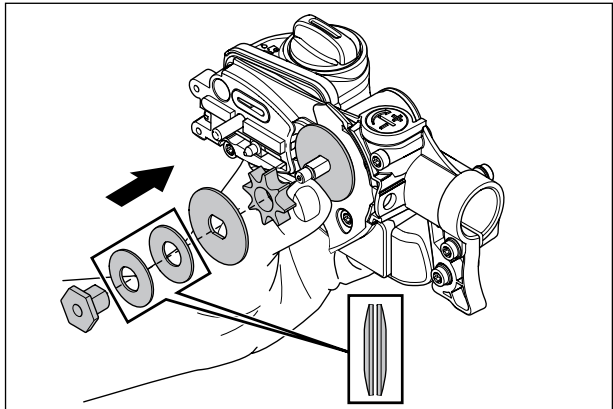

Tighten the nut. Make sure to counterhold on the inner washer when tighten the nut, see figure.

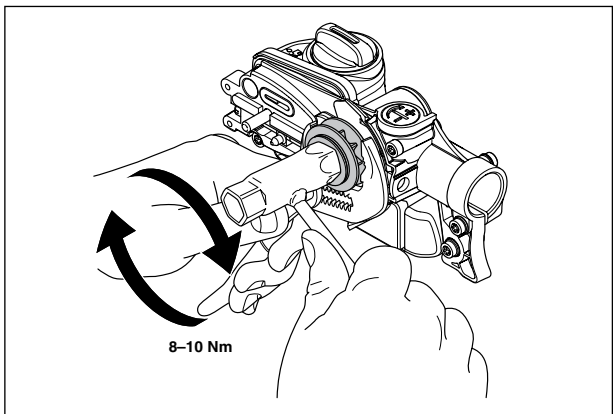

Assembly bar and chain and the plastic cover (B). tighten the nut (A)
Put the saw head on the shaft and tighten the nuts (D, C).
Make sure the hole on the saw head align with the hole on the shaft. Tighten screw D by hand to make sure it fits in the hole in the shaft. Tighten the screw.

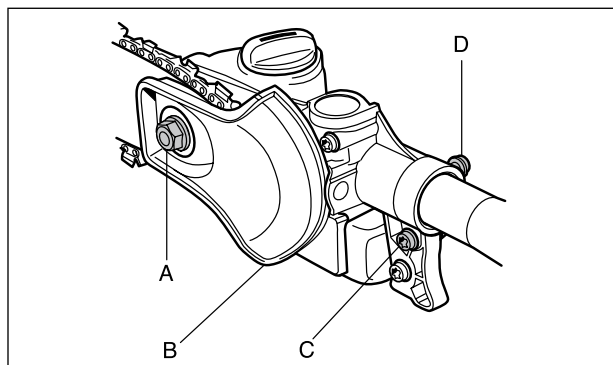

7.29 Dismantling the telescopic tube (PT5S)

Dismantling

Remove the saw head from the telescopic tube as described above.

Disconnect the cables (B) and the throttle wire from carburetor. Remove cover if needed.

Loosen screws (A) one on the top cover and two screws on the side, see figure.

Loosen the two screws (C) and remove screw (E).
Remove the telescopic tube from the clutch cover.

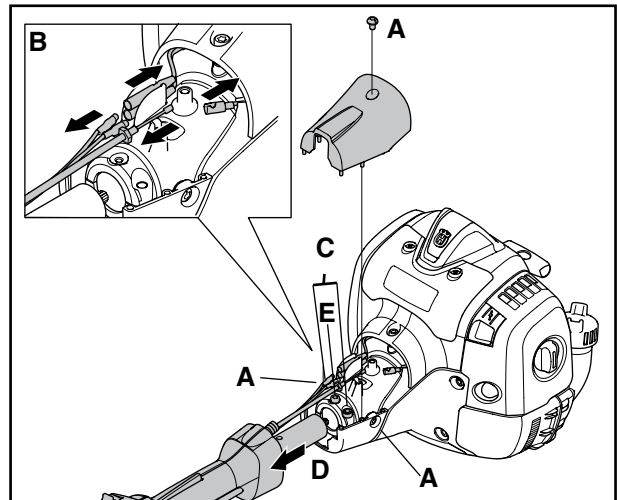

Dismantling and assembly take place only from the engine side.

Pull out the drive shaft (A) and the plastic pipe (B).
Then also pull out the long drive shaft. Note that the shaft has a small 48 cm circlip at the shaft end.

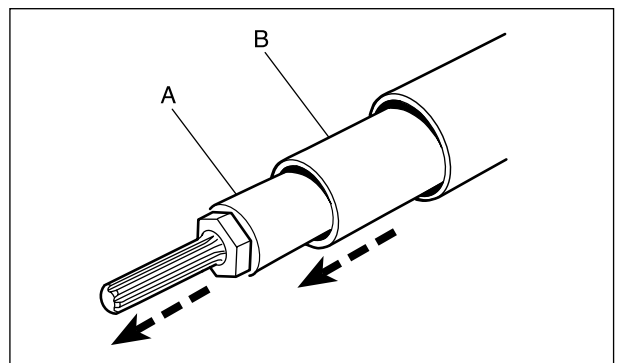

Pull out the drive shaft (C) at the saw head end of the telescopic tube.

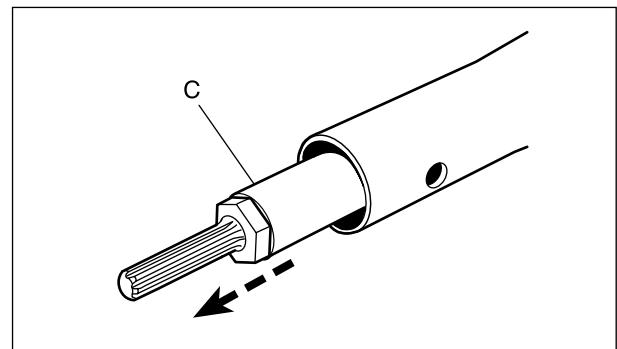

Loosen the locking nut (D) anticlockwise and let the pipe (E) jump out.

Loosen the screws (F).

Pull out the clamping sleeve (G) and the telescopic pipe (E) from the telescopic tube (H).

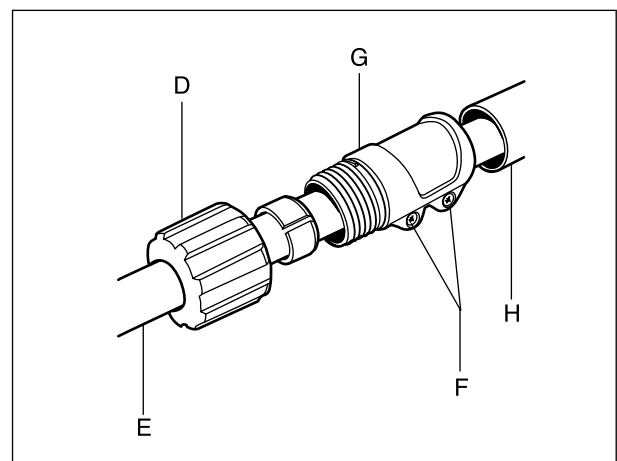

Loosen the screw holding the throttle control cover (I).

Loosen the three screws (J) holding the clamping sleeve.

Slide the throttle control cover and the clamping sleeve off the telescopic tube. Separate the clamping sleeve with a screwdriver if required.

Remove the screw (K) and pull out the pipe (L) together with the rubber sleeve (M) from the telescopic tube.

TIP!

Press a screwdriver in between the rubber sleeve and the tube and spray with silicone to facilitate dismantling.

Use a screw driver to press down the clip and pull out the bearing and axle control.

Pull springs and ball bearings out of the telescopic tube.

Remove the circlip (N), the ball bearing (O) and the axle control (P) from the bearing cage (Q).

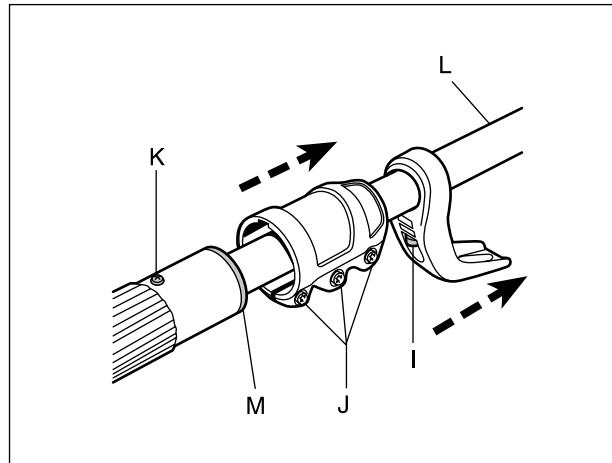

Note!

Note which direction the axle control (P) is turned in the ball bearings and the telescopic tube.

The axle control are always pointed towards sawhead

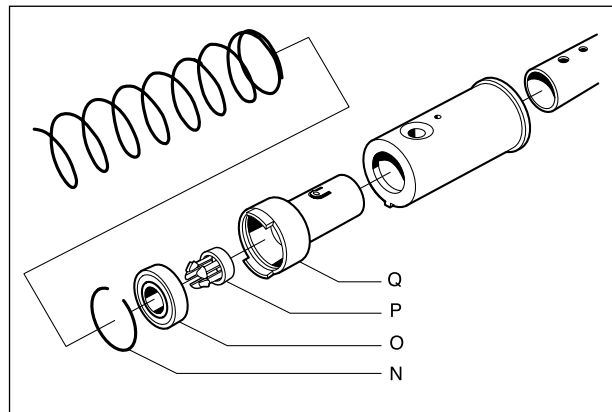

7.30 Assembling the telescopic tube (PT5S)

Assembly

Assemble the different components in the reverse order as set out for dismantling.

First fit the axle control (P) in the ball bearing (in the right direction) and then the ball bearing in the bearing cage.

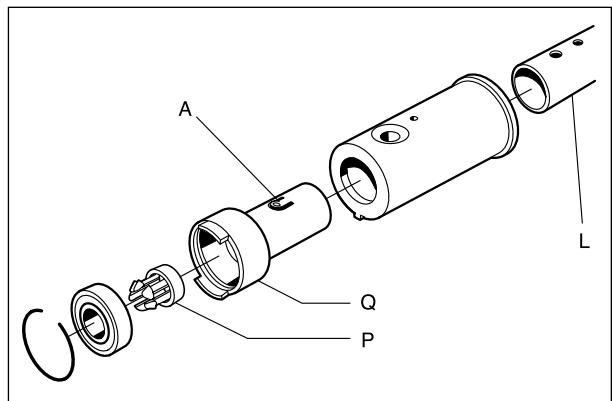

Then push the bearing cage into the rubber sleeve. Slide the pipe (L) over the bearing cage and make sure the spring tongues (A) on the bearing cage snap in place on the tube.

Lubricate all components with a thin layer of grease and continue assembling.

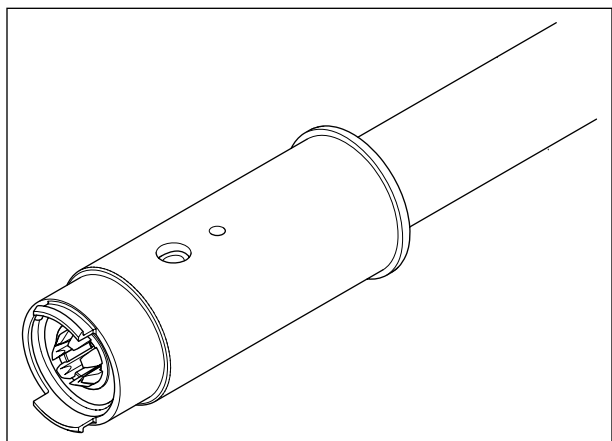

Connect the 3 springs with the bearing cages.

Make sure that the bearing cages following the track inside the shaft. On the top of the bearing cages there is a protruding part that must follow the track inside the tube.

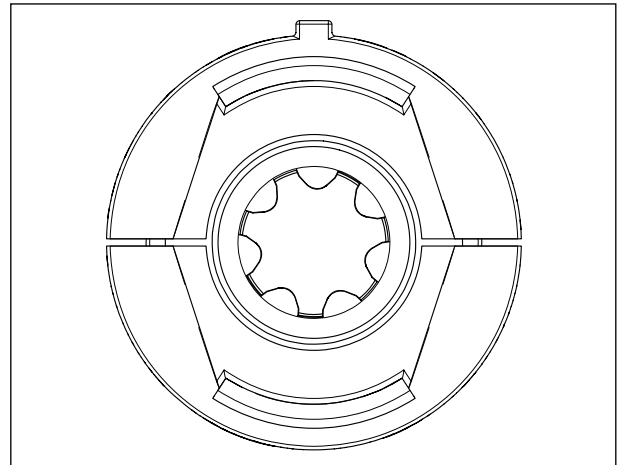

Make sure they are turned in the right direction so that the axle control in the ball bearing protrudes into the telescopic tube.

Note!

Note which direction the axle control (P) is turned in the ball bearings and the telescopic tube.

The axle control are always pointed towards sawhead

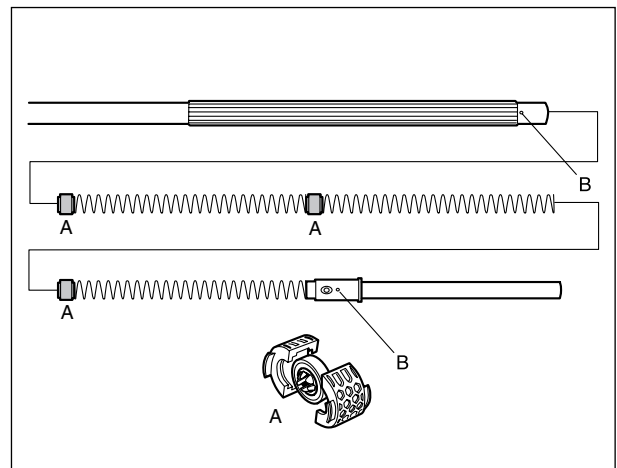

Assembly clamping sleeve lower

Do not forget then to tighten the screw that fits in hole (B) and lock the pipes in relation to each other. Tighten the 3 screws on the clamping sleeve.

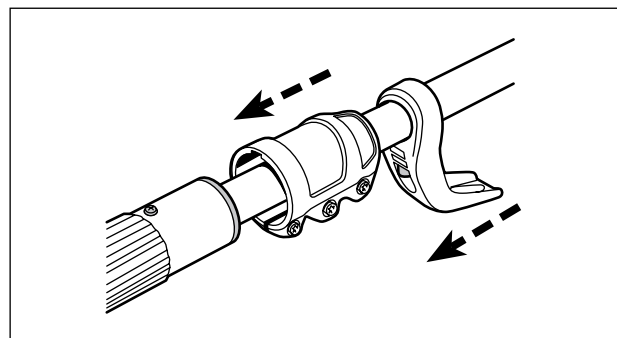

Mount upper part of tube

Mount upper clamping sleeve (G) on the telescopic tube (H) and put the telescopic pipe (E) together with telescopic tube (H). Tighten the screws (F). Tighten the locking nut (D)

Note! the stirring gap on the telescopic tube when assembly the clamping sleeve.

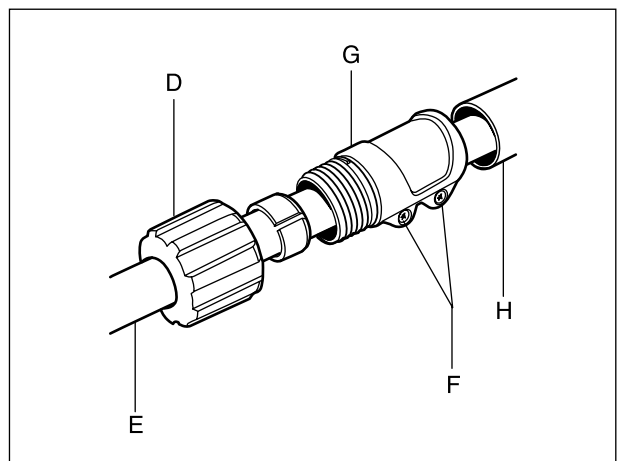

Assembly drive shaft into tube

Apply some grease on the drive shafts, mounted from engine side and from saw head side.

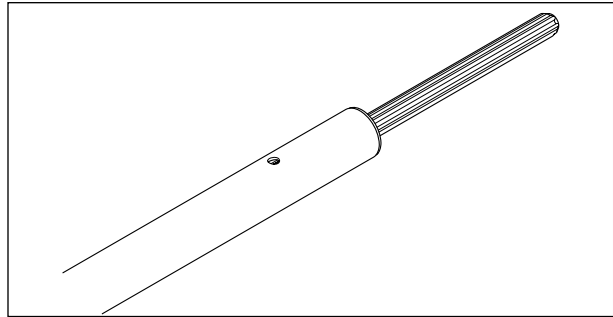

Mount drive shaft from engine side and from saw head side.

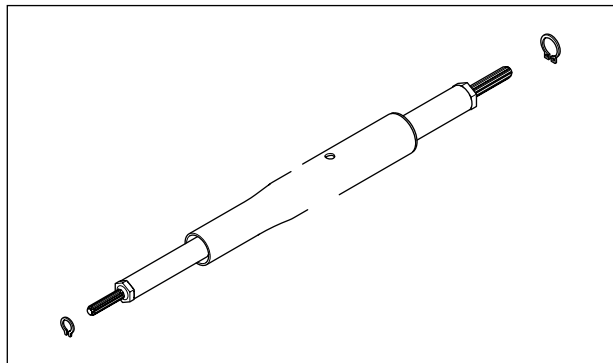

Assembly saw head

Put the saw head on the shaft and tighten the nuts (D, C).

Make sure the hole on the saw head align with the hole on the shaft. Tighten screw D by hand to make sure it fits in the hole in the shaft. Tighten the screw.

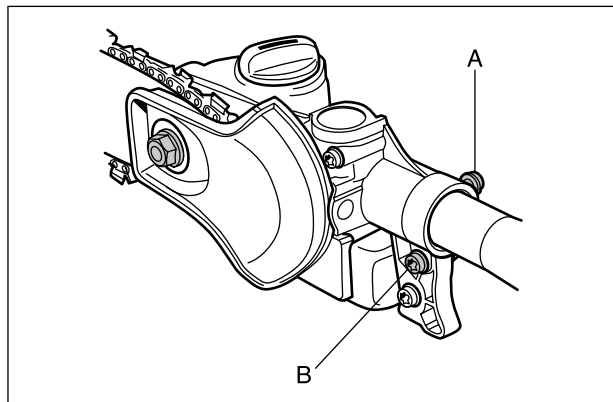

7.31 Assembly saw head, shaft and engine

Saw head must be mounted on the tube shaft. Press the tube shaft (D) into the clutch drum. Make sure the drive shaft connect to the splines in the clutch drum.

TIP!

To make sure the drive shaft is connected to the splines in the clutch drum rotate the chain on a piece of wood forwards and backwards.

Tighten the screws (C, E).

Make sure that the throttle wire is correct mounted in it's indentation. Connect the throttle wire. Connect the two cables from ignition modules (B).

Assembly covers and thighten the nuts (A)

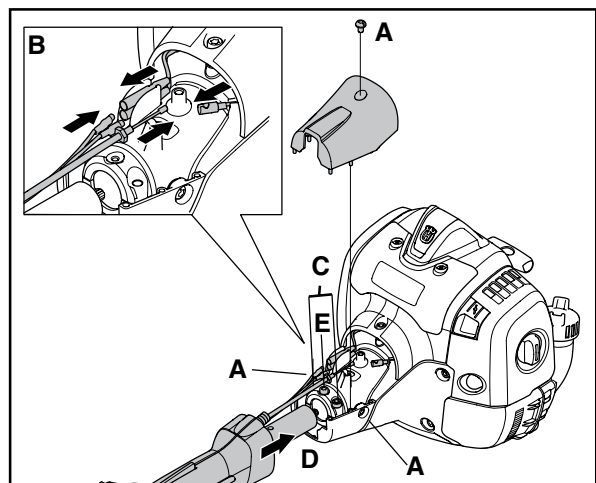

7.32 Dismantling the shaft (P4S, P5S)

Loosen the screw (A) and remove the cover.

Detach the cables (B).

Loosen the screws (C) and remove screw (E).

Pull out the shaft (D) from the engine.

Detach the shaft from the saw head as described in chapter 7.33.

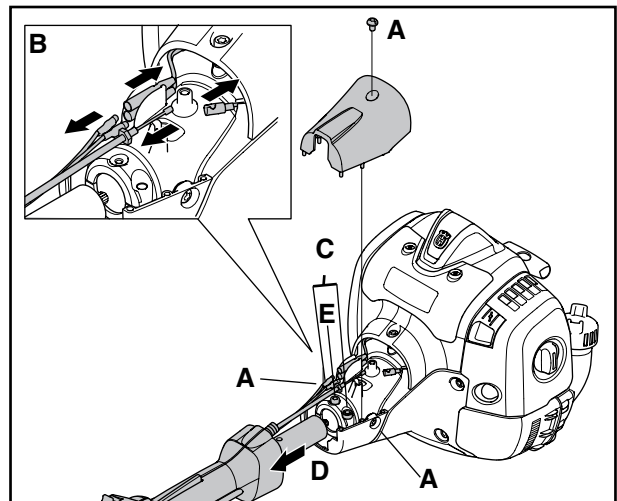

Remove the drive shaft from the tube shaft.

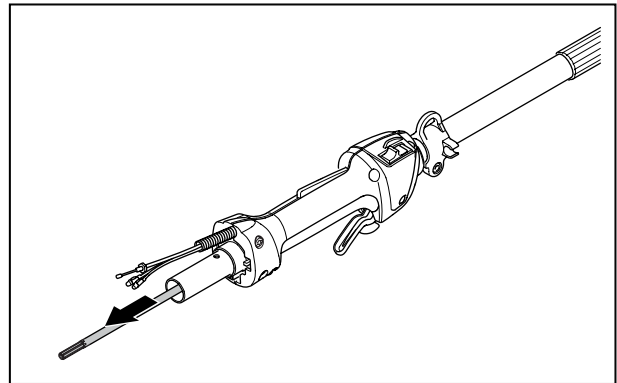

7.33 Dismantling the saw head (P4S and P5S)

Dismantle the saw head from the tube and remove the chain.

Loosen the screw (C).

Unscrew the screw (D) as much as required in order to twist the saw head and detach it from the tube.

Remove the nut (A) and lift off the cover.

Remove the chain (B) and bar.

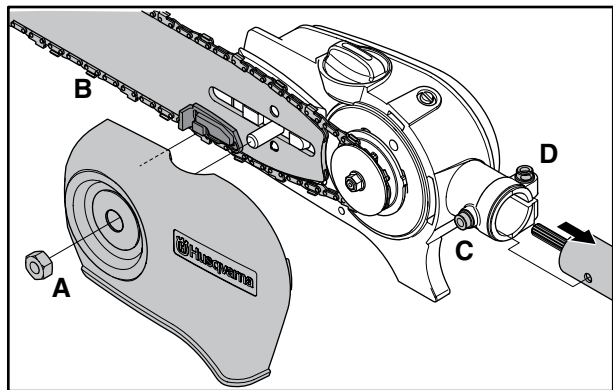

Remove the nut and washer that fixates the spur unto the saw head.

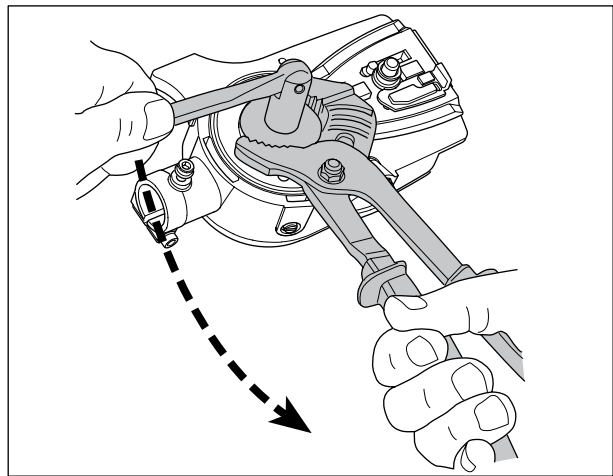

Remove all spur components (washer, hub, bushing and ring) as well as the hub cap.

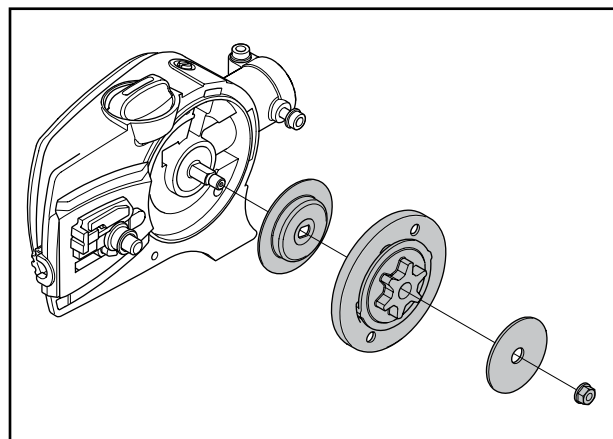

Remove the bar bolt (A), chain tensioner (B) followed by the, the chain guide plate, and the oil duct (C).

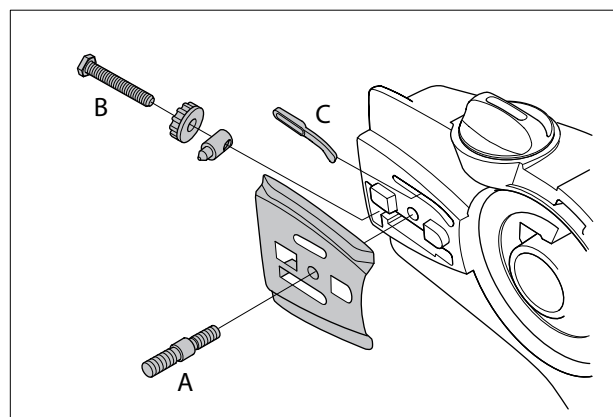

Loosen the screws (A) and remove the oil tank coverage. Remove the sealing and the O-ring. Remove the oil tank cap (B). Remove the oil hose and related parts (C). Remove the adjuster and spring (D).

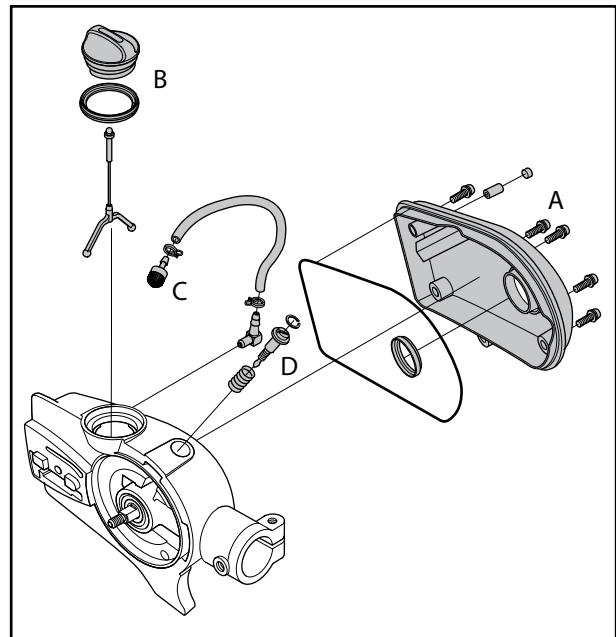

Remove the gear wheel kits from the saw head by pulling those outwards from saw head.

(1) Remove the large circlip holding the ball bearing for the pinion using a couple of pliers. Heat the saw housing using a hot air gun, approximately 110°C, and knock it gently against a wooden block so that the pinion with the ball bearing falls out.

Remove the drive shaft by using remaining heat knock it gently against a wooden block.

Loosen and remove the circlips (preferably using a snap ring plier), and separate ball bearings and spacer from gear wheel shafts.

Visually inspect if the ball bearings are in proper condition; if necessary replace.

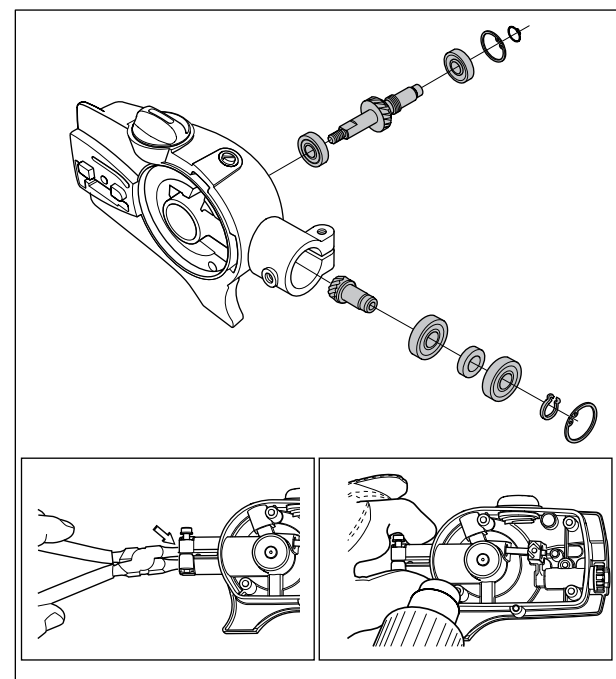

Remove the oil pump assembly.

Note: Always use Grease with art. no: 502 22 97-01 on the wheels (B,H) and in the gear.

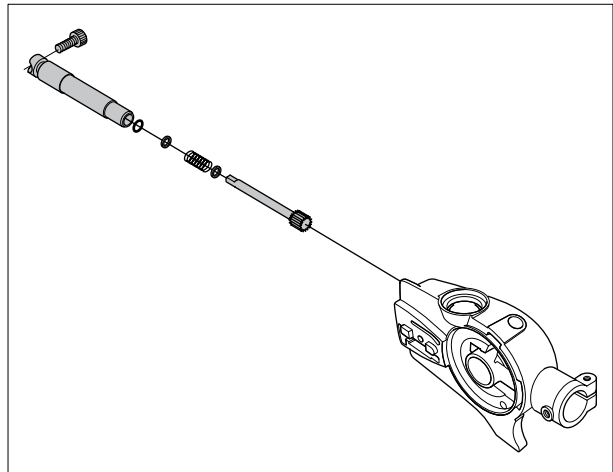

Clean and inspect all components. Replace any worn or defective components.

Grease the details with grease type 502 22 97-01 before putting the parts back together. Fill all the bearings with grease.

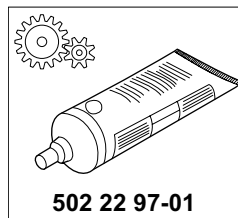

Blow the chain lubrication channel free from debris using compressed air. This to make sure the channel is not clogged. Blow in both directions.

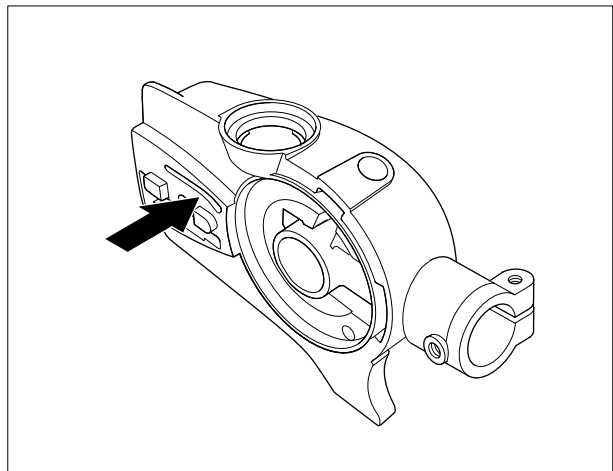

7.34 Assembling the saw head (P4S and P5S)

Assemble the different components in the reverse order as set out for dismantling in chapter 7.33.

Make sure the the filter on the oil hose is in the bottom of the oil tank.

Assemble the chain (B) on the flywheel and attach the sealing plate (E) inside the cover.

To fit the shaft onto the saw head, carry out the following;

Install the drive shaft into the shaft.
Fit the drive shaft into the saw head.
Make sure the locating screw (C) becomes properly mounted unto its fixing point on tube; then tighten. Tighten the screw (D).

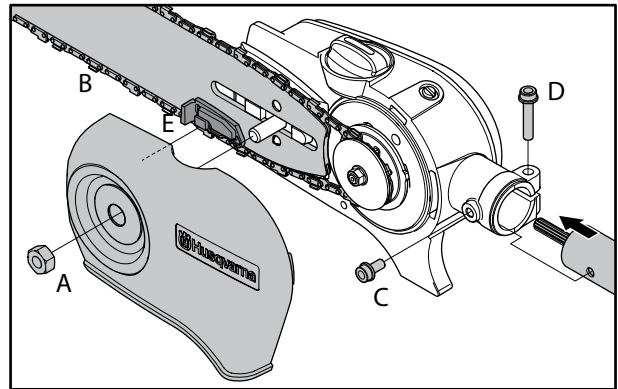

7.35 Assembly saw head, shaft and engine (P4S, P5S)

Saw head must be mounted on the tube shaft.
Press the tube shaft (D) into the clutch drum. Make sure the drive shaft connect to the splines in the clutch drum.

TIP!

To make sure the drive shaft is connected to the splines in the clutch drum rotate the chain on a piece of wood forwards and backwards.

Tighten the screws (C, E).
Make sure that the throttle wire is correct mounted in it's indentation. Connect the throttle wire.
Connect the two cables from ignition modules (B).

Assembly covers and thighten the nuts (A)

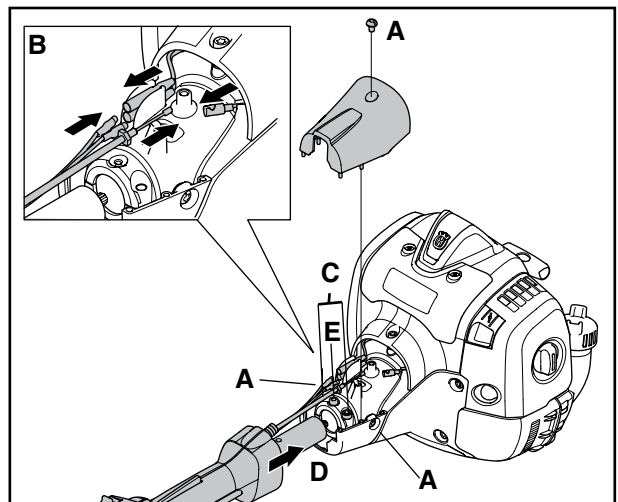

8 Troubleshooting

Contents

8.1	Engine does not start	79
8.2	Engine stops working during operation	80
8.3	Engine is difficult to stop	80
8.4	Insufficient output or unstable rotation	81
8.5	Other engine problems	82

8 Troubleshooting

8.1 Engine does not start

Remove the spark plug from the cylinder, and holding the cylinder, pull the recoil starter and check whether any sparks appear between the spark plug electrodes.

Symptom/Category	Cause	Action
There are no sparks at the spark plug		
Spark plug	1. The spark plug electrodes are wet	Dry them
	2. Carbon has built up on the spark plug electrodes	Remove the carbon or replace with a new one.
	3. Insulation is poor due to cracks, etc. on the spark plug insulator	Replace with a new one.
	4. The gap between the spark plug electrodes is excessively small or large	BPMR8Y: Adjust to 0.65 mm
Magneto	1. Poor coil insulation	Replace
	2. The cable trunking has been damaged or the cable is broken	Repair or replace
	3. Poor air gap between the rotor and coil	Adjust to 0.3 mm
	4. Damage to the plug and gap spring	Replace
Switch	1. The switch is OFF	Set the switch to "RUN"
	2. The switch is faulty	Replace
	3. The primary wire is earthed	Repair or replace
There are sparks at the spark plug		
Compression is good and fuel flows	1. Excessive fuel intake	Discharge the excess gas
	2. Fuel is too thick	Repair or replace the carburetor
	3. Overflow	Adjust or replace the carburetor
	4. The air cleaner is soiled	Clean in a gasoline mixture and dry thoroughly
	5. Poor quality fuel is being used	Replace with good quality fuel
Fuel flows, but compression is poor	1. The spark plug is loose	Tighten
	2. Wear or damage to the cylinder, piston, piston	Replace
	3. Gas is leaking from around the cylinder and crankcase	Replace gasket with new one and re-assemble
No fuel flows	1. Poor carburetor adjustment	Adjust
	2. Blockage inside the carburetor	Clean
	3. Blockage in the fuel filter	Clean or replace the fuel filter
	4. Fuel hose damage or blockage	Adjust

8.2 Engine stops working during operation

Symptom/Category	Cause	Action
There are no sparks at the spark plug		
Engine suddenly stops	1. The switch has been touched, stopping the engine	Restart
	2. The switch is OFF	Operate by setting to "RUN" or "I"
	3. The plug cap has come off	Fit it back on fully
	4. The switch cable or high-voltage cable trunking is worn	Replace
	5. Internal fault in the coil	Replace
	6. The engine has burned out	Disassemble and repair
	7. The breather air vent is blocked	Clean
Rotation gradually decreases and the engine stops	1. Lack of fuel	Fill with fuel
	2. Blockage inside the carburetor	Clean
	3. There is water in the fuel	Discharge and clean the inside of the tank, then fill with good quality fuel
Rotation suddenly increases, and then the engine stops	1. Lack of fuel	Fill with fuel
	2. The breather air vent is blocked	Clean
	3. Blockage inside the carburetor	Clean

8.3 Engine is difficult to stop

Symptom/Category	Cause	Action
Engine suddenly stops	1. Fuel is thin	Adjust, repair or replace the carburetor
	2. Blockage due to dirt in the air passage for cooling	Clean
	3. Blockage due to dirt on the cylinder fin	Clean
	4. Poor quality fuel is being used	Replace with good quality fuel
	5. Carbon has collected in the combustion chamber (run-on occurs)	Clean
	6. The spark plug tip is red hot	BPMP8Y: Adjust to 0.65 mm
Switch	1. Faulty switch	Replace
	2. Cable is broken	Replace
	3. Internal fault in the ignition module	Replace

8.4 Insufficient output or unstable rotation

Symptom/Category	Cause	Action
Compression is good and there is no flame out	1. Air has entered through the fuel pipe joint, etc.	Insert it securely
	2. Air has entered the fuel pipe due to a crack or pin hole	Replace
	3. Air has entered through the insulator pulse pipe insertion part, etc.	Insert it securely
	4. Air has entered through the insulator and carburetor installation part	Replace or tighten the gasket
	5. Air has entered through the oil seal, etc.	Replace
	6. There is water in the fuel	Discharge and clean the inside of the tank, then fill with good quality fuel
	7. The piston appears to have been burned	Remove the burn with a fine file, or replace
	8. Carbon blockage in the muffler	Clean
Excessive heat	1. Fuel is thin	Repair or replace the carburetor
	2. Blockage due to dirt in the air passage for cooling	Clean
	3. Blockage due to dirt on the cylinder fin, etc.	Clean
	4. Poor quality fuel is being used	Replace with good quality fuel
	5. Carbon has built up in the combustion chamber	Clean
	6. The spark plug tip is red hot	Clean carefully, and BPMR8Y: Adjust to 0.65 mm
Other	1. The air cleaner is soiled	Replace it with a new one
	2. Excessive load	Reduce the load

8.5 Other Engine problems

Symptom/Category	Cause	Action
Even if the engine revolution is decreased, the blade does not stop	1. The clutch spring is broken	Replace the engine's clutch spring
	2. The clutch is open due to rusting of the clutch bolts	De-rust the clutch bolts, apply grease and re-assemble
	3. The shoe lining has peeled off	Replace the shoe
Even if the engine revolution is increased, the blade does not rotate	1. The shaft is broken	Replace
	2. The flexible shaft is broken (back-supported type)	Replace
	3. Drum bearing is stuck	Replace
	4. Gear damage inside the gear case	Repair or replace
	5. Gear damage inside the swivel gear case	Repair or replace
	6. Damage to the joint-C spring	Replace
	7. Abnormal wear to the drum and shaft's spline	Replace
Abnormal vibration	1. Blade eccentricity	Fit the cutter holder (holder A) firmly and re-assemble
	2. The chip saw's tip has worn down by a third or more	Replace the chip saw
	3. Pipe is bent	
	4. The blade has a high peripheral balance	Set the blade's teeth or replace
	5. The shaft is bent	Replace
	6. The shaft damper is damaged or broken	Replace
	7. The outer pipe is bent	Replace
	8. Wear or movement of the bushing	Replace the pipe
	9. Eccentricity of the drum	Replace the drum
	10. Significant weight difference on the clutch shoe	Replace the clutch shoe



www.husqvarna.com

114 02 95-26

2015W11