

Workshop manual

536Li XP/535i XP, 436Li/330i

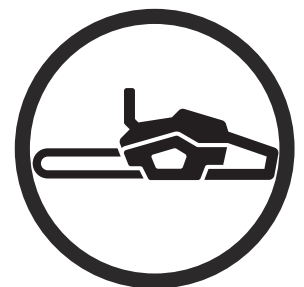

English

Contents

1 Introduction

1.1 Document description.....	3
1.2 Target group.....	3
1.3 Revisions.....	3
1.4 Safety.....	3
1.5 Servicing tools.....	3

2 Safety

2.1 Safety definitions.....	4
2.2 General safety instructions.....	4
2.3 Symbols on the product.....	4
2.4 Special safety instructions.....	4

3 Servicing data

3.1 Servicing data 536Li XP/535i XP and 436Li/ 330i.....	5
-------------------------------------------------------------	---

4 Servicing tools

4.1 Diagnostic tool kit.....	7
------------------------------	---

5 Repair instructions

5.1 To clean and examine the product parts.....	8
5.2 To replace the guide bar bolt.....	8
5.3 To replace the chip guard.....	8
5.4 To replace the chain oil cap.....	8
5.5 To repair damaged threads.....	8
5.6 To replace the chain catcher.....	9
5.7 To replace the spiked bumper.....	9
5.8 Drive wheel cover and guide bar.....	9
5.9 Crankcase.....	9
5.10 Power trigger.....	9
5.11 Front hand guard.....	10
5.12 Motor.....	11
5.13 Impeller.....	12
5.14 Main switch S/N -20180600001.....	13
5.15 Main switch S/N 20180600001-.....	14
5.16 Control unit S/N -20151600245	15
5.17 Control unit S/N 20151600245-.....	16
5.18 Replacing the keypad S/N -20151600245	17
5.19 Chain brake.....	18
5.20 Chain brake sensor.....	19
5.21 Oil pump.....	20
5.22 Chain tensioner 536Li XP/535i XP.....	21
5.23 Chain tensioner 436Li/330i.....	22

6 Troubleshooting

6.1 To connect the common service tool.....	23
6.2 To do troubleshooting of the common service tool.....	23
6.3 Troubleshooting of the product.....	23
6.4 Troubleshooting of the battery and battery charger.....	25
6.5 Troubleshooting appendix.....	26

1 Introduction

1.1 Document description

This manual gives a full description of how to do maintenance and repair on the product. It also gives safety instructions that the personnel must obey.

1.2 Target group

This manual is for personnel with a general knowledge of how to do repair and do servicing. All personnel that do repair or do servicing on the product must read and understand the manual.

1.3 Revisions

Changes to the product can cause changes to the maintenance work and spare parts. Separate information is sent out for each change.

Read the manual together with all received information about changes to maintenance and spare parts for the product.

1.4 Safety



WARNING: All personnel that repair or do servicing on the product must read and understand the safety instructions in this workshop manual.

1.5 Servicing tools

The manual gives information about necessary servicing tools. Always use original tools from Husqvarna.

2 Safety

2.1 Safety definitions

Warnings, cautions and notes are used to point out specially important parts of the manual.



WARNING: Used if there is a risk of injury or death for the operator or bystanders if the instructions in the manual are not obeyed.



CAUTION: Used if there is a risk of damage to the product, other materials or the adjacent area if the instructions in the manual are not obeyed.

Note: Used to give more information that is necessary in a given situation.

2.2 General safety instructions



WARNING: Apply a new warning label if a warning symbol on the product is damaged or missing.

2.3 Symbols on the product



Fill with chain oil



Indication of chain direction

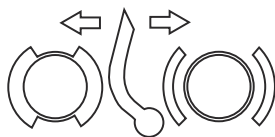

Chain brake



Start/Stop



savE / Battery save mode



Warning lamp/Fault indicator



Adjustable handle

2.4 Special safety instructions

2.4.1 To remove the battery



WARNING: Always remove the battery before you do repairs or do servicing on the product.



WARNING: Do not put the battery back until the product is assembled.

1. Press in the catches (1) and remove the battery (2).

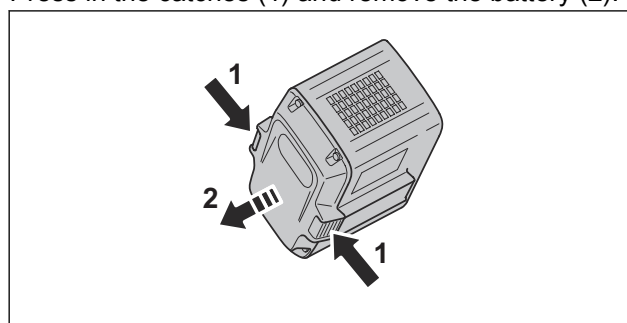

3 Servicing data

3.1 Servicing data 536Li XP/535i XP and 436Li/330i

The numbers show the tightening torque for the components in Nm.

- ▲ Lubricate with chainsaw oil
- Lubricate with grease

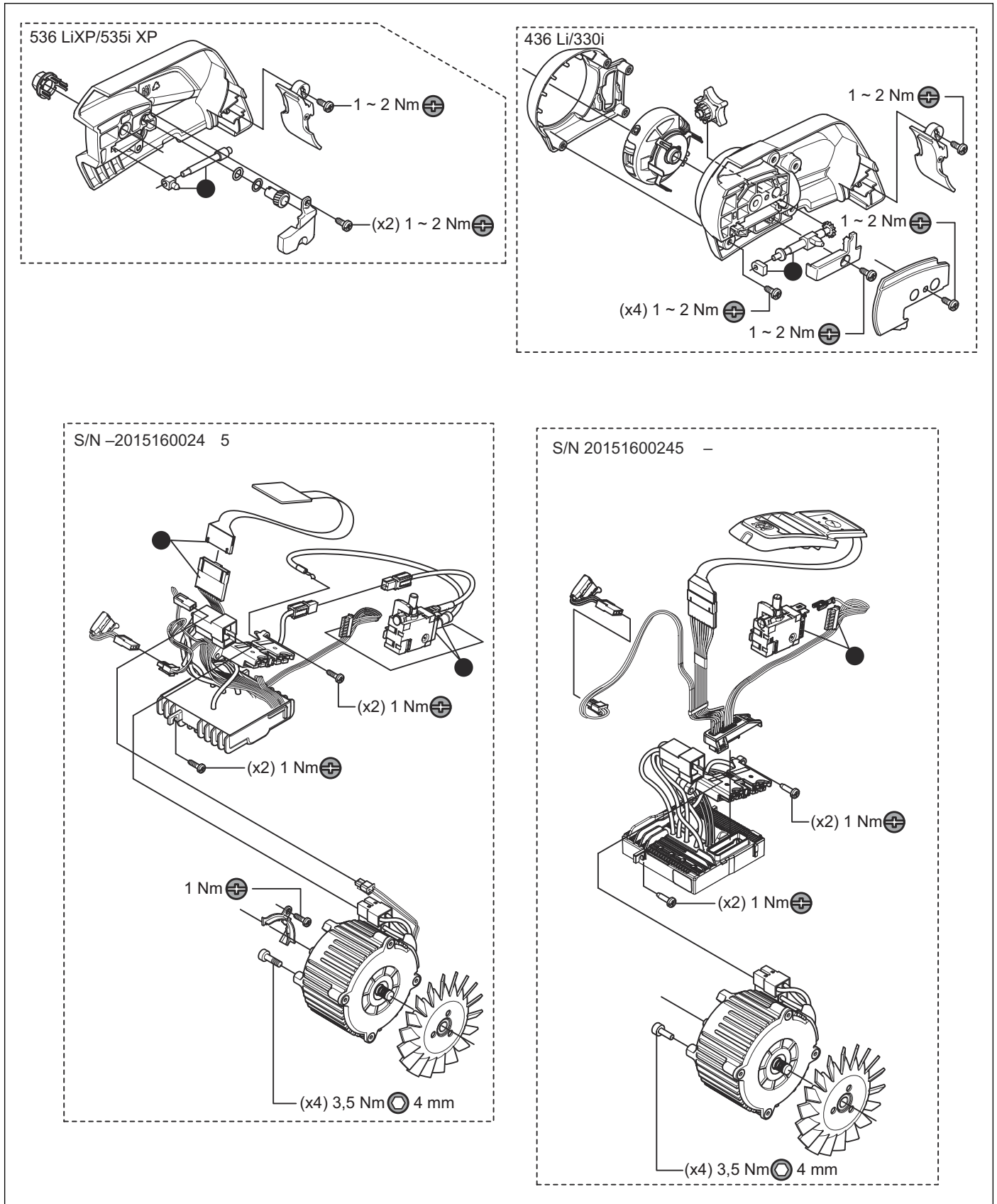

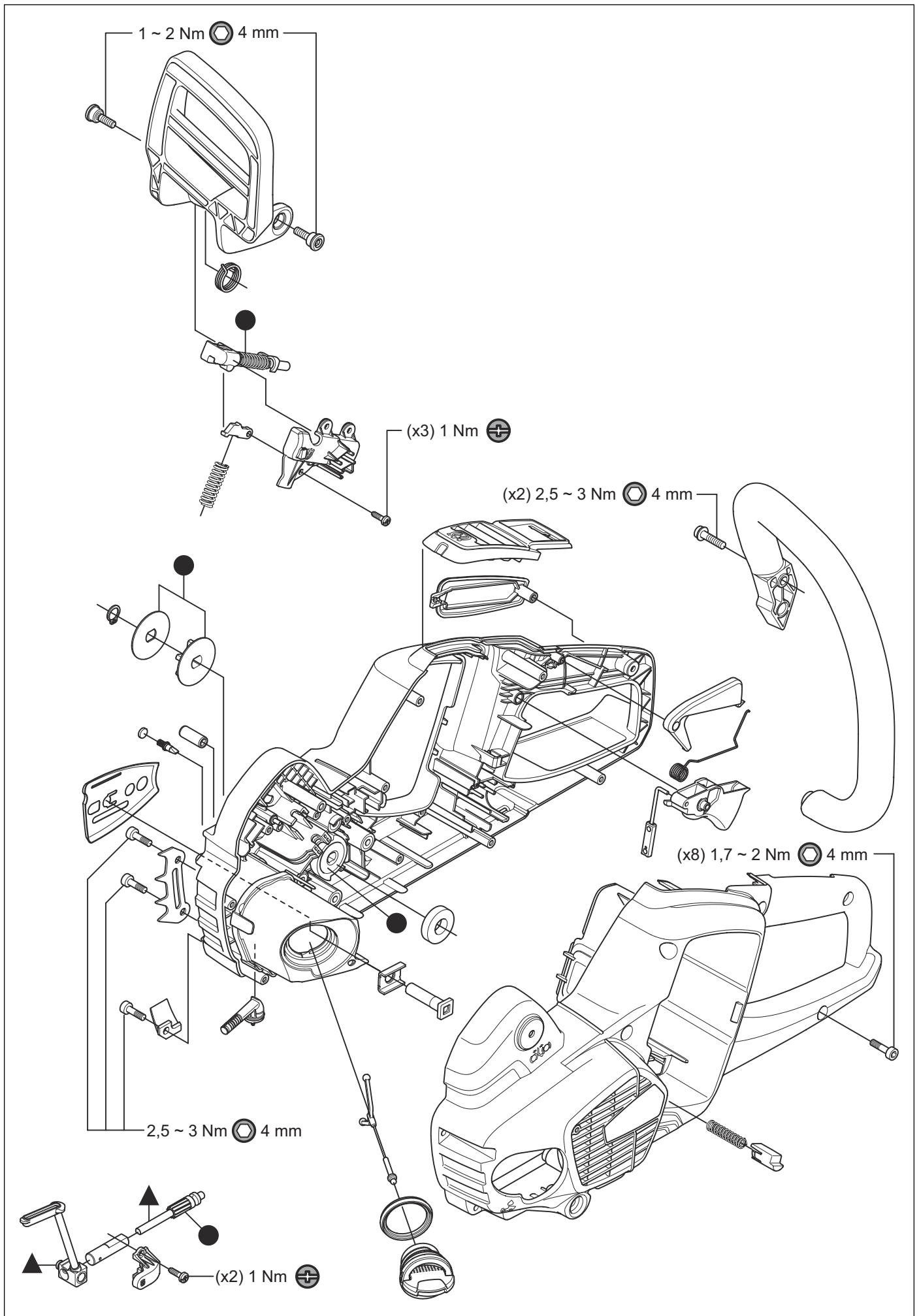

4 Servicing tools

4.1 Diagnostic tool kit

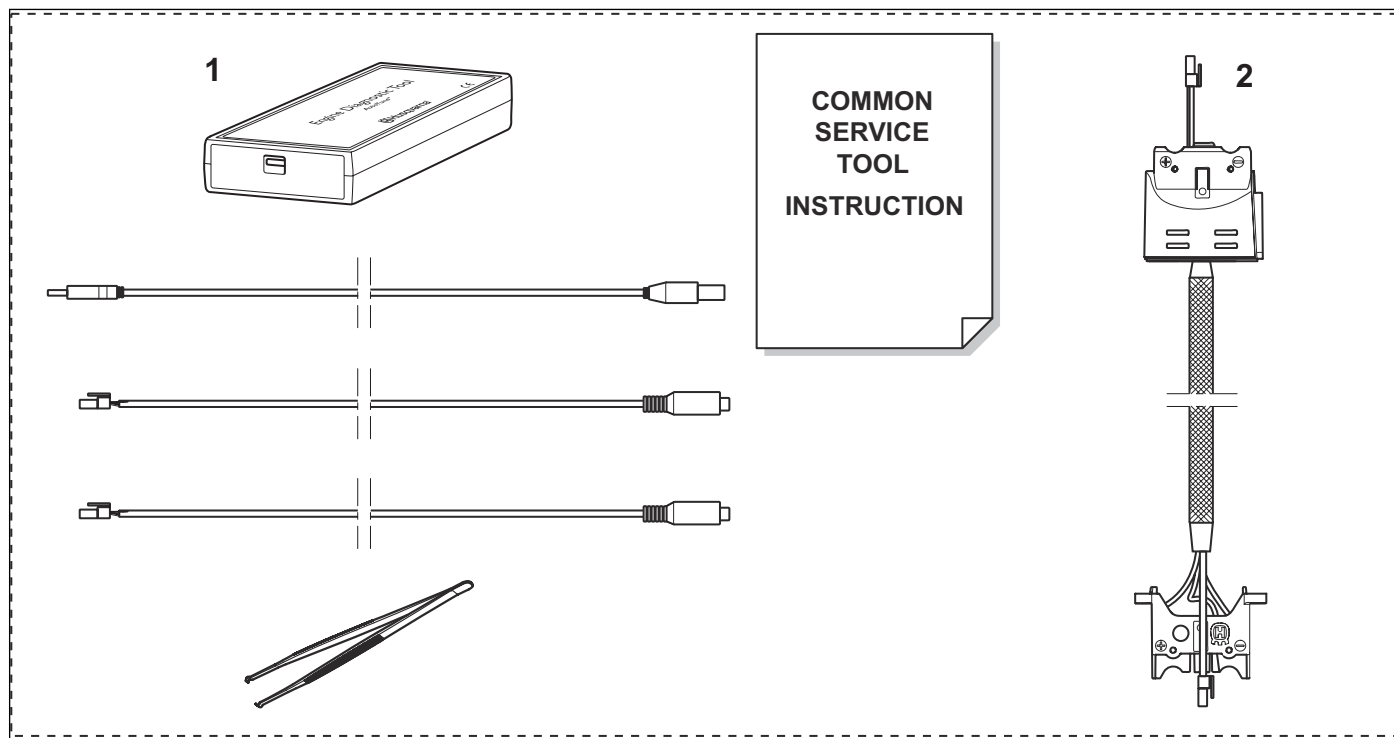

4.1.1 Common service tool

The common service tool (CST) tool is used with a computer (not included) for Husqvarna products.

The common service tool transmits data from the product and battery to the computer, for example

product ID. There is also a diagnostic tool list and a list of saved error codes. The common service tool is also used to update the software in battery products.

Pos.	Designation	Used for	Order No.
1	Diagnostic Tool Kit	Troubleshooting	583 89 71-01
2	Adapter cable for battery products	Troubleshooting	579 62 13-01

5 Repair instructions

5.1 To clean and examine the product parts

- Clean and examine all parts fully. You find more instructions in the chapter for each part if special tools or procedures are necessary.
- Replace damaged or defective parts.
- Always use original spare parts.

5.2 To replace the guide bar bolt

Note: Make sure that the guide bar bolt and the washer for the guide bar bolt are put correctly in the crankcase.

1. Disassemble the drive wheel cover, saw chain and guide bar. See *To remove the drive wheel cover and guide bar on page 9*.
2. Empty the chain oil tank.
3. Hit the worn guide bar bolt to make it fall into the chain oil tank.
4. Move the guide bar bolt (B) and its washer (A) from the chain oil tank.
5. Put the guide bar bolt washer (A) on the guide bar bolt (B).

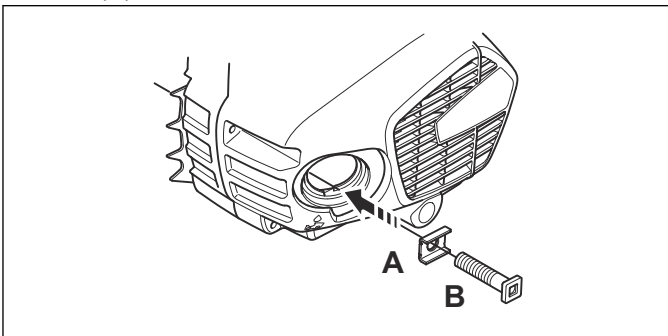

6. Put them into the chain oil tank with pliers and through the hole in the crankcase.
7. Pull out the guide bar bolt with a nut. Put a spacer between the nut and the crankcase.

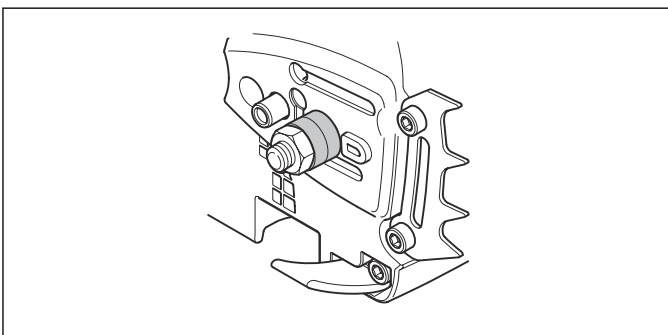

8. Assemble the crankcase. See *To assemble the crankcase on page 9*
9. Fill with chain oil.

5.3 To replace the chip guard

Note: Always replace a worn chip guard with a new one.

1. Disassemble the drive wheel cover, saw chain and bar.
2. Remove the screw and replace the chip guard.

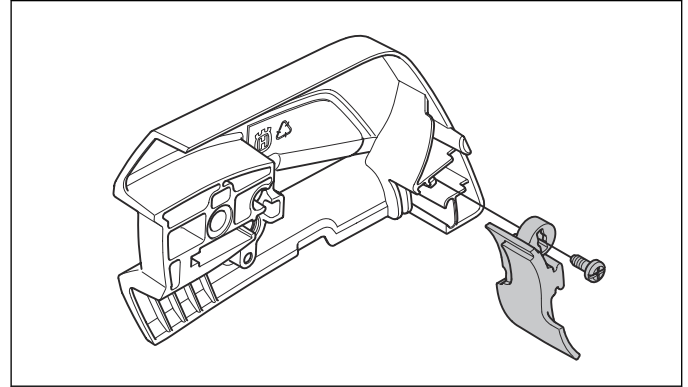

5.4 To replace the chain oil cap

1. Empty the chain oil tank.
2. Put a combination wrench in the groove in the cap.
3. Turn the wrench counterclockwise.

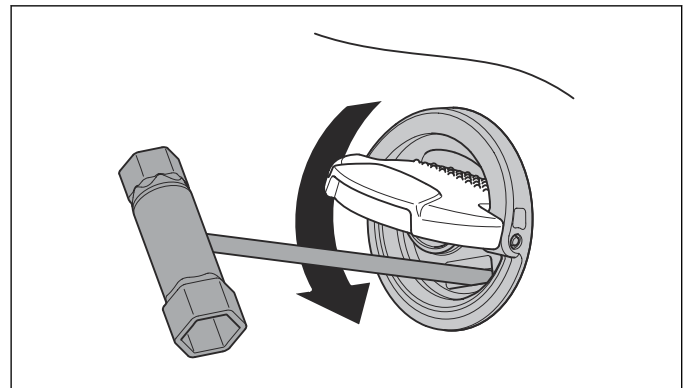

4. Replace the damaged cap with a new cap.

5.5 To repair damaged threads

1. If the plastic threads in the chassis are damaged, make a hole with a 4.5 mm drill bit.
2. Replace the original screw with the screw 503 21 74-16 - IHSCT MT5x16.

5.6 To replace the chain catcher

Always replace a worn chain catcher with a new one.

1. Disassemble the drive wheel cover, the saw chain and the guide bar. *To remove the drive wheel cover and guide bar on page 9.*
2. Remove the screw and replace the chain catcher.

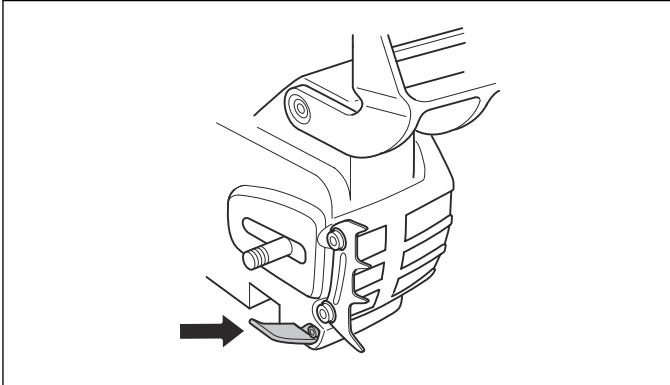

5.7 To replace the spiked bumper

Always replace a worn spiked bumper with a new one.

1. Disassemble the drive wheel cover, the saw chain and the guide bar. See *To remove the drive wheel cover and guide bar on page 9*
2. Remove the screws and replace the spiked bumper.

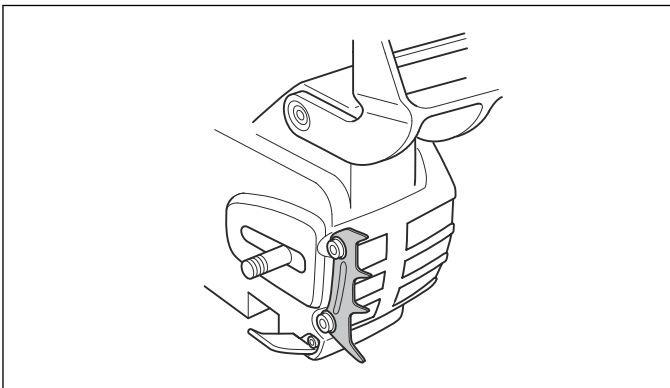

5.8 Drive wheel cover and guide bar

5.8.1 To remove the drive wheel cover and guide bar

1. Release the chain brake by moving the hand guard rearward.
2. Remove the drive wheel cover and guide bar nut, 536Li XP/535i XP, or knob, 436Li/330i.

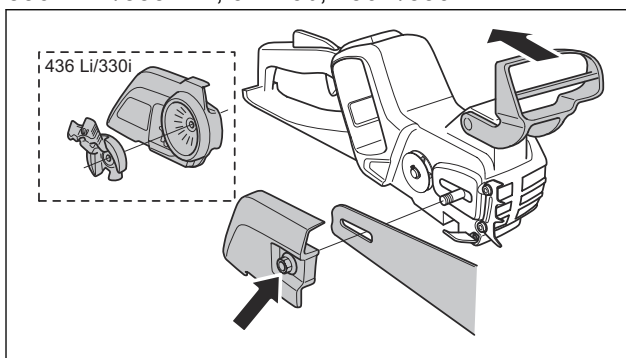

3. Remove the cover, saw chain and guide bar.

5.8.2 To assemble the drive wheel cover and guide bar

- Assemble the drive wheel cover and guide bar in the opposite sequence of *To remove the drive wheel cover and guide bar on page 9.*

5.9 Crankcase

5.9.1 To disassemble the crankcase



CAUTION: Make sure that all parts are put correctly in the crankcase to prevent damage to the cables.

1. Remove the 8 screws.

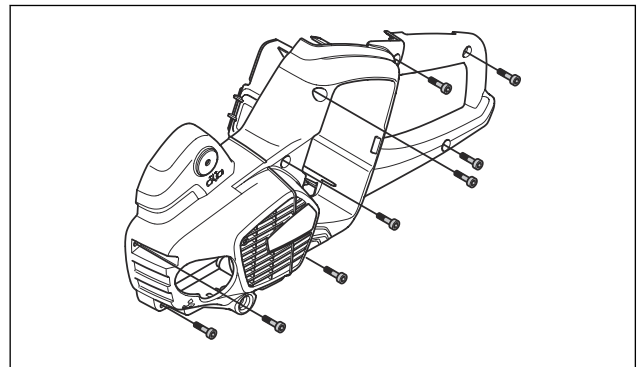

2. Remove the crankcase half.

5.9.2 To assemble the crankcase

- Assemble the crankcase in the opposite sequence of *To disassemble the crankcase on page 9.*

5.10 Power trigger

5.10.1 To disassemble the power trigger

1. Remove the drive wheel cover, the saw chain and guide bar. See *To remove the drive wheel cover and guide bar on page 9.*
2. Disassemble the crankcase. *To disassemble the crankcase on page 9*
3. Remove the power trigger lockout and the power trigger from their brackets in the handle.

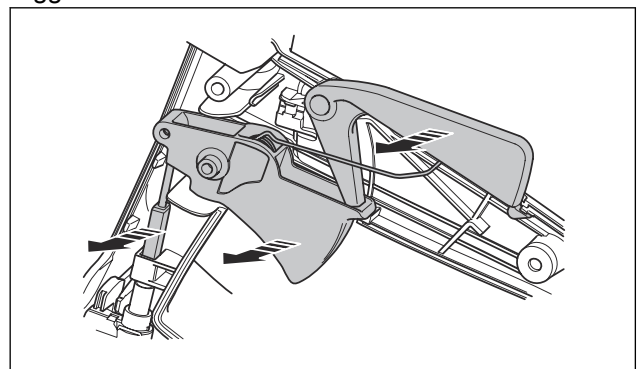

- Remove the main switch piston and the recoil spring from its holding in the throttle.

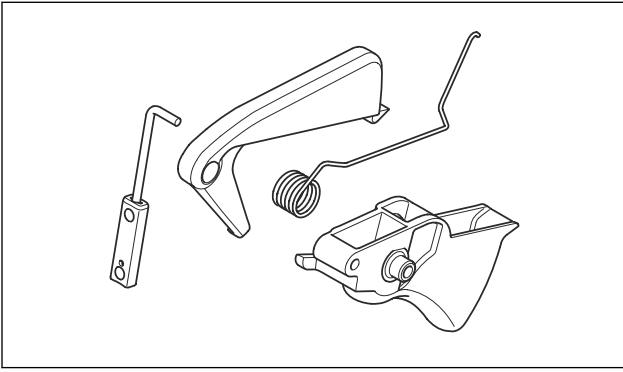

- Make sure that there is tension in the recoil spring.

5.10.2 To assemble the power trigger

- Put the recoil spring and main switch piston onto the throttle.
- Assemble the throttle and the power trigger and power trigger lockout to their brackets in the handle.
- Make sure the holders are in the handle.

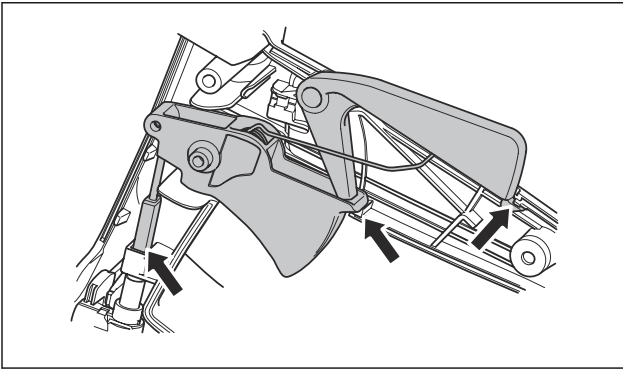

- Put the recoil spring in the throttle lockout.

5.11 Front hand guard

5.11.1 To disassemble the front hand guard



WARNING: Use protective goggles. The spring in the hand guard can eject and cause injury.

- Make sure the product does not move during the following procedure.
- Disassemble the drive wheel cover, the saw chain and the guide bar.
- Move the hand guard rearward to release the brake. This makes the assembly of the hand guard easier.

- Remove the screws (A and B) for the front hand guard.

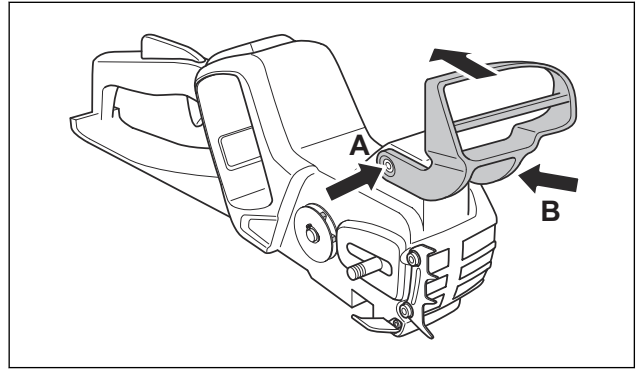

- Carefully turn the front hand guard horizontally. Keep turning until the screw hole in the front hand guard is released the holding (B) on the product.

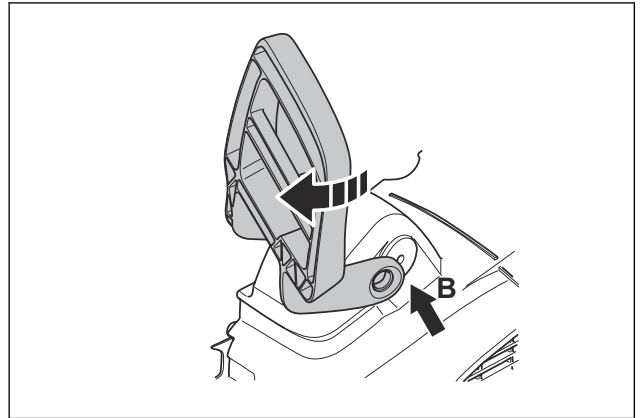

- Turn the front handle guard down and away from the product. Keep turning until the heel in the front handle guard (C) is released from the heel in the product (D).

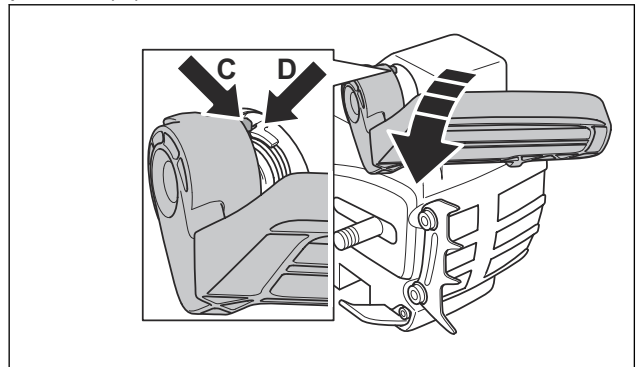

5.11.2 To assemble the front hand guard



WARNING: Use protective goggles. The spring in the hand guard can eject and cause injury.

1. Put the brake pin in its position.

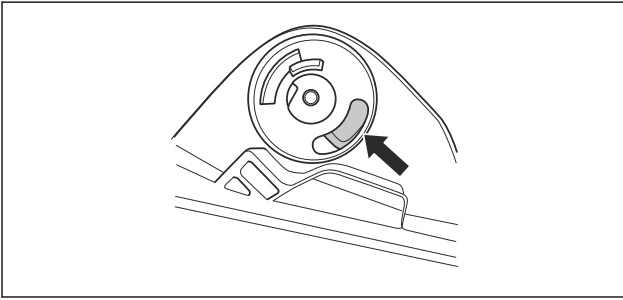

2. Put the spring in its position and tension it.

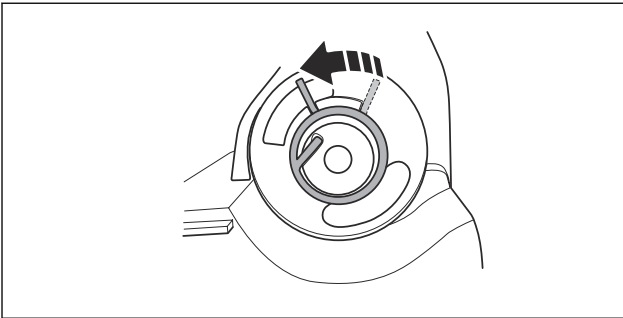

3. Make sure the product can not move during the following procedure.
4. Align the hand guard holding and hold the hand guard in position.

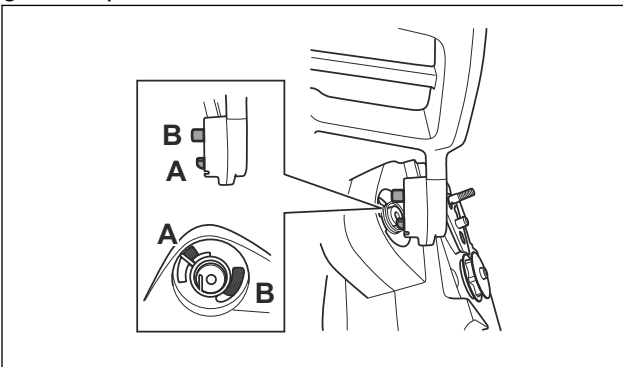

5. Pull the hand guard on to the holding on the left side.

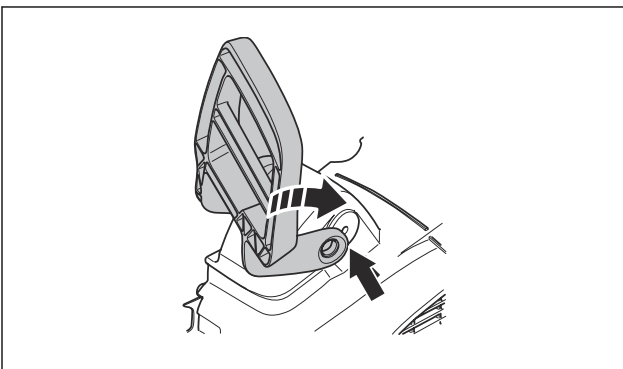

6. Put the spring into the slot on the hand guard.

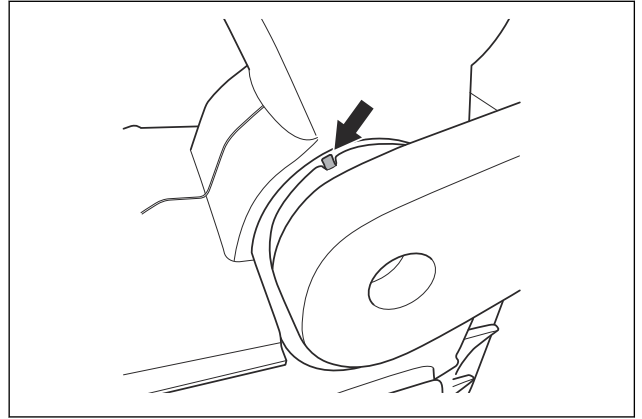

7. Attach the screws (A and B).

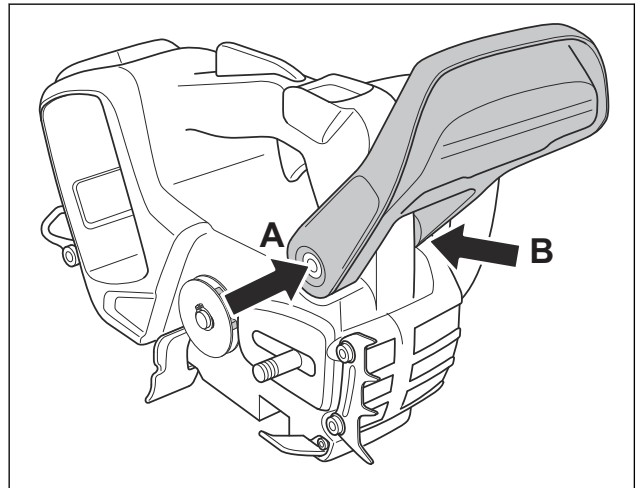

8. Try the hand guard to make sure the hand guard is attached correctly.

5.12 Motor

5.12.1 To disassemble the motor



CAUTION: Do not pull the wires.

1. Remove the drive wheel cover, the saw chain and the guide bar. See *To remove the drive wheel cover and guide bar on page 9*
2. Remove the crankcase. See *To disassemble the crankcase on page 9*
3. Remove the screws.

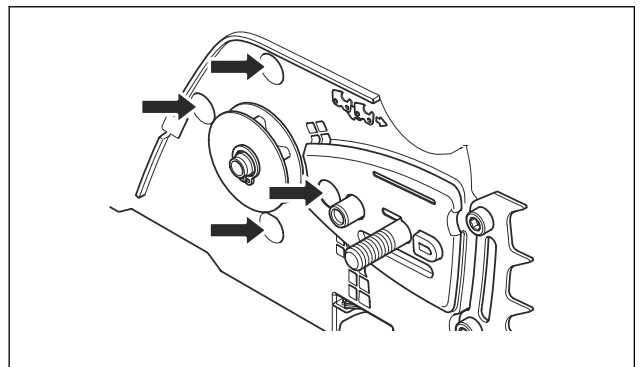

- Press in holder (A) and disconnect the connector (B).

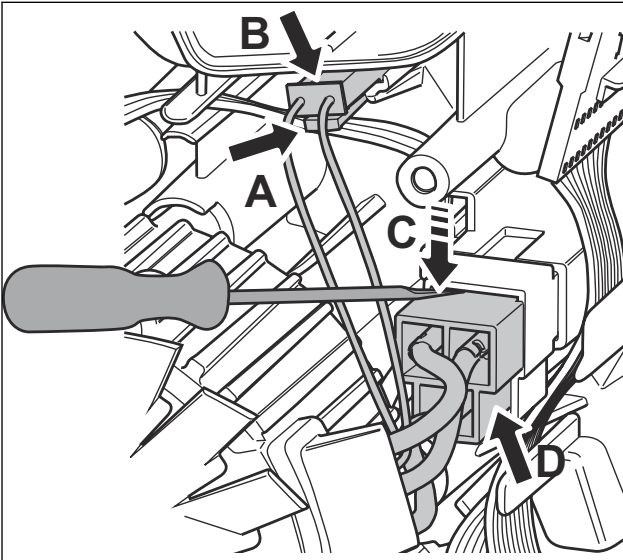

- Put a screwdriver (C) above the connector (D) and carefully press down to release and disconnect the connector.
- Remove the motor.

5.12.2 To assemble the motor



CAUTION: Do not let the cables get caught between other motor parts.

- Put the motor on its brackets.
- Connect the connectors.
- Attach the chain brake sensor cable (C) to the crankcase groove above the motor.
- Make sure that the motor control cable (D) is on top of the motor. If not, there is a risk that it comes loose and gets caught in the clutch shaft.

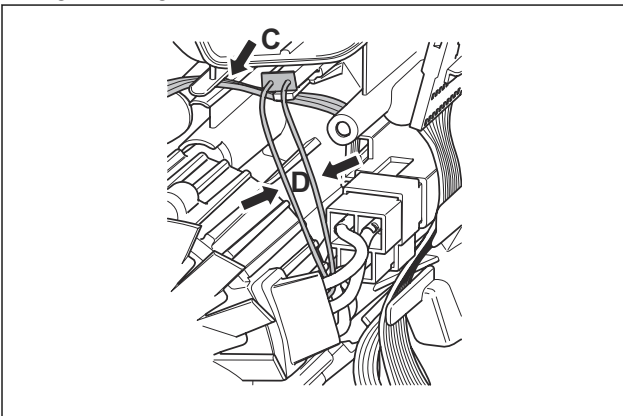

- Rotate the motor shaft until it aligns with the drive shaft.
- Attach the motor with the screws.
- Assemble the product.

For motor with temperature sensor (-20140101) and Gen. 1 control unit

Put the loose connector in the holder (D). No connection is necessary.

For motor without temperature sensor (20140101-) and Gen. 2 control unit

No connection is necessary.

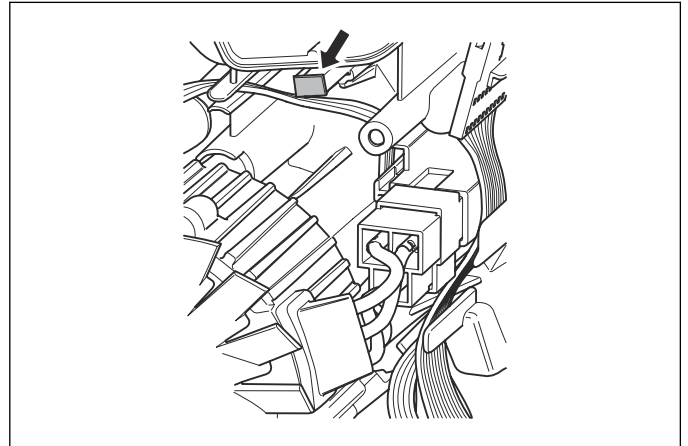

5.13 Impeller

5.13.1 To disassemble the impeller

Note: The impeller can be removed with the motor attached or removed.

- Remove the drive wheel cover, the saw chain and the guide bar. See *To remove the drive wheel cover and guide bar on page 9*.
- Disassemble the crankcase. See *To disassemble the crankcase on page 9*.
- Insert a screwdriver between the motor and the impeller to remove the impeller from the motor.

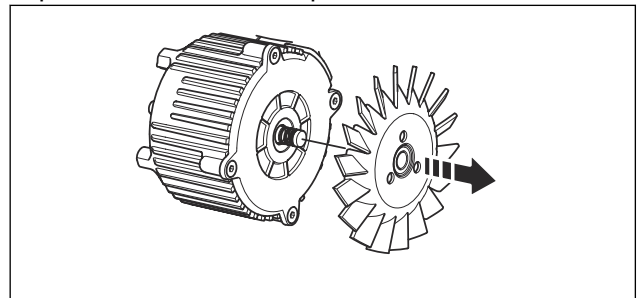

5.13.2 To assemble the impeller

- Press the impeller onto the motor. The motor shaft (A) must not be more than 1.85 mm or 0.073 above the impeller.

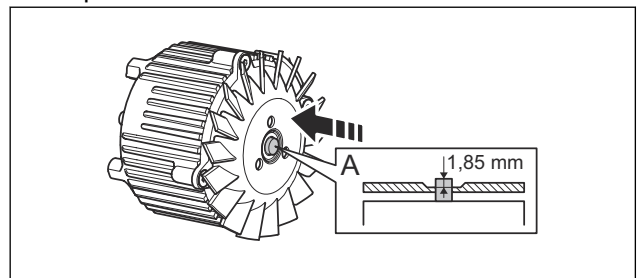

5.14 Main switch S/N -20180600001

5.14.1 To remove the main switch



CAUTION: Do not pull the cables.

1. Remove the drive wheel cover, the saw chain and the guide bar. See *To remove the drive wheel cover and guide bar on page 9.*
2. Disassemble the crankcase. See *To disassemble the crankcase on page 9.*
3. Remove the main switch and wire.
4. Disconnect the connector (B).

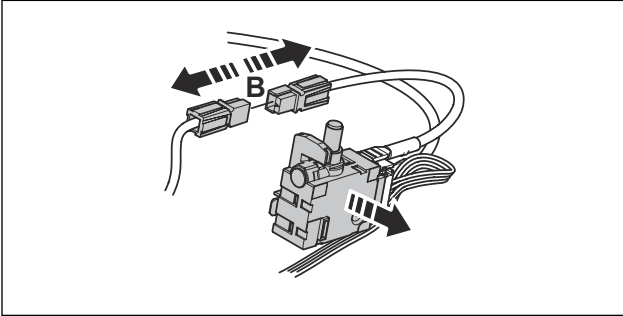

5. Carefully free the catches (D) on each end of the connector with a small screwdriver.

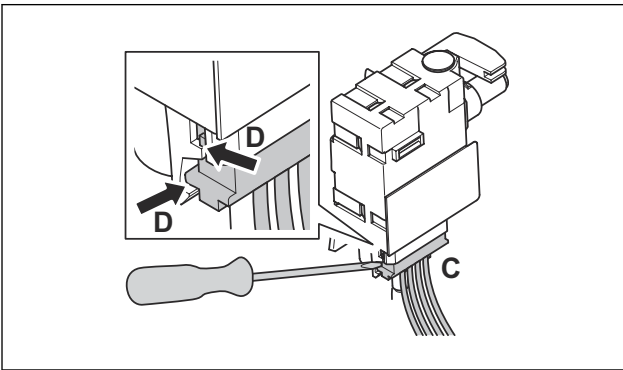

6. Disconnect the connector (C).
7. Loosen the screws and remove the battery connector from the crankcase.

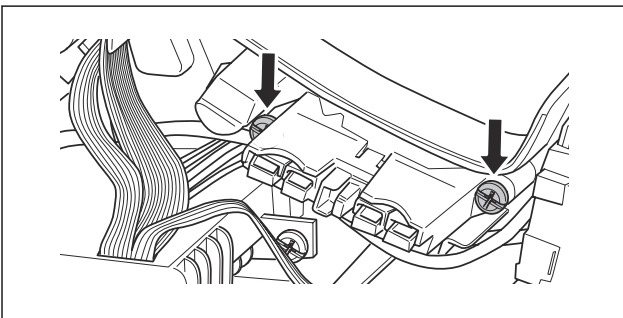

8. Disconnect the connector cable from the battery connector. Push the connector spring (X) with a screwdriver to release the pin (Y).

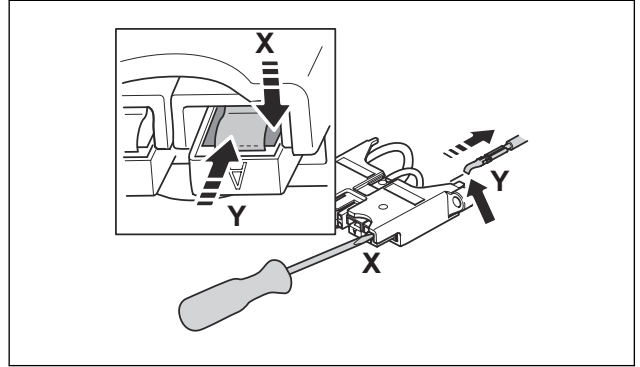

9. Pull the cable out. Do not bend the pin.

5.14.2 To attach the main switch

1. Connect the red wire from the control cable to the battery connector. Carefully press the cable until the pin connects onto the connector.



CAUTION: Do not bend the pin.

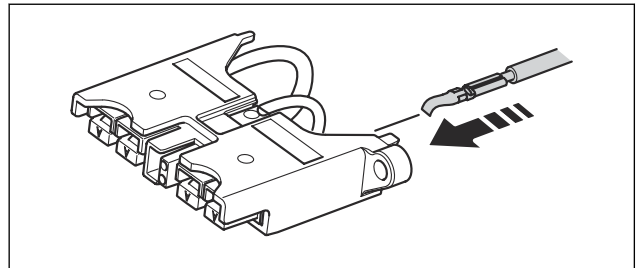

2. Attach the battery connector to the crankcase.

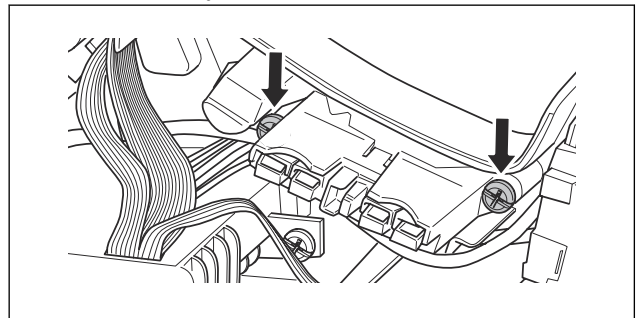

3. To prevent corrosion on the main switch connector, put grease on the pins before you attach the main switch.

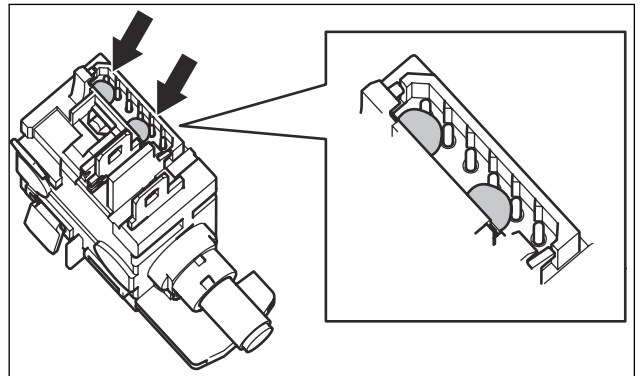

4. Connect the connectors (B) and attach the connector (C) to the main switch.

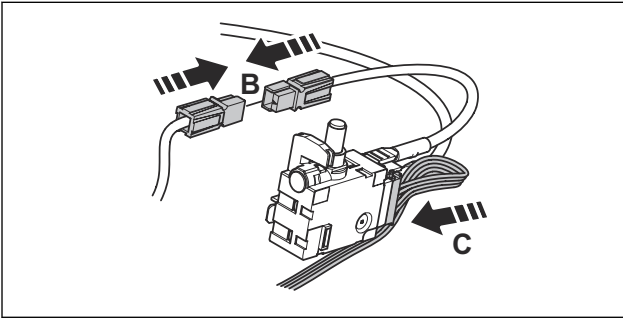

5. Put grease on the connector and the yellow wires.

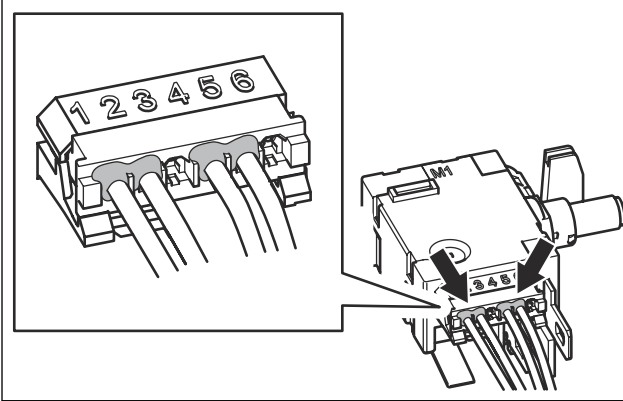

6. Put the cables and the main switch in the crankcase.

Note: Make sure that you put the cables correctly to prevent damage to the cables when the product is assembled.

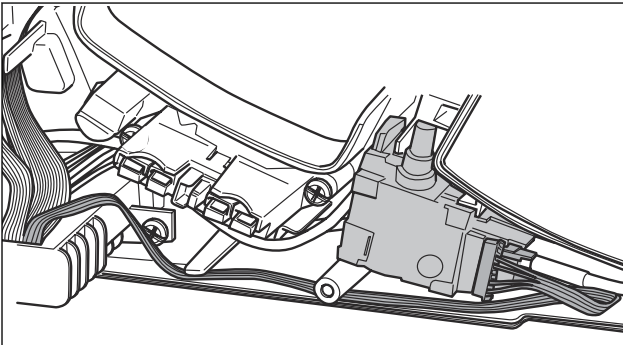

5.15 Main switch S/N 20180600001-

5.15.1 To disassemble the main switch



CAUTION: Do not pull the cables.

1. Remove the drive wheel cover, the saw chain and the guide bar. See #
2. Disassemble the crankcase. See #

3. Remove the main switch from the crankcase.

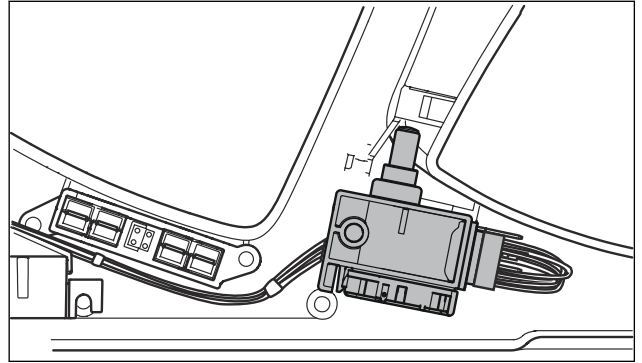

4. Carefully free the catches (D) on each end of the connector with a small screwdriver.

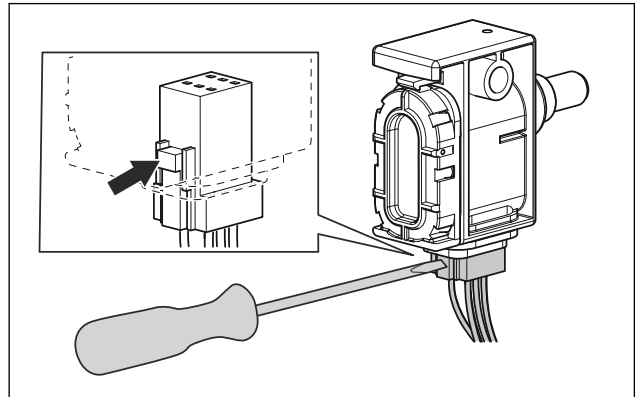

5. Disconnect the connector (C).

5.15.2 To assemble the main switch

1. Connect the cable to the main switch.

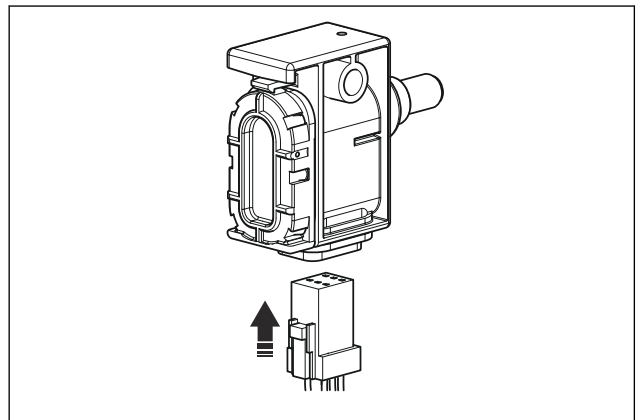

2. Put the cables as shown in figure.

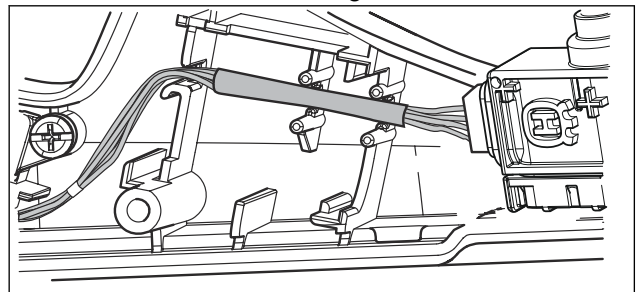

- Put the main switch as shown in figure.

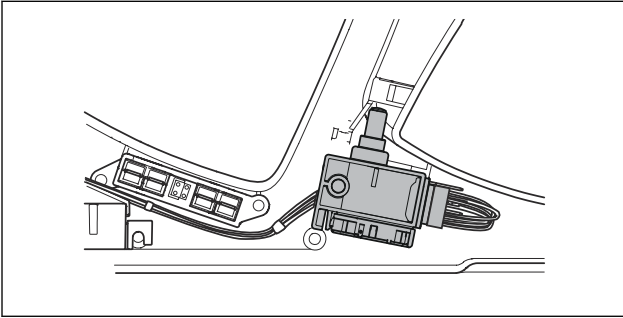

- Assemble the product.

5.16 Control unit S/N -20151600245

5.16.1 To disassemble the control unit

Note: Look at how cables and other components are assembled before you disassemble. Be careful when you assemble and make sure that the cables do not get caught between other parts.

- Disassemble the drive wheel cover, saw chain and guide bar. See *To remove the drive wheel cover and guide bar on page 9*.
- Disassemble the crankcase. See *To disassemble the crankcase on page 9*.
- Disassemble the motor. See *To disassemble the motor on page 11*.
- Remove and disconnect the connector from the keypad. See *To disassemble the keypad on page 18*.
- Remove the main switch and disconnect the connectors. See *To remove the main switch on page 13*.
- Disconnect the connector from the chain brake sensor.

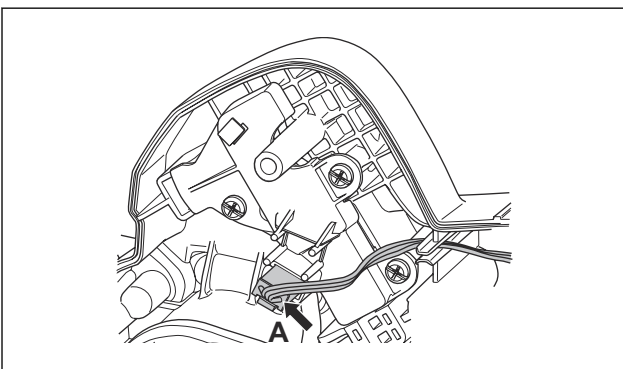

- Remove the screw to the cable holder.

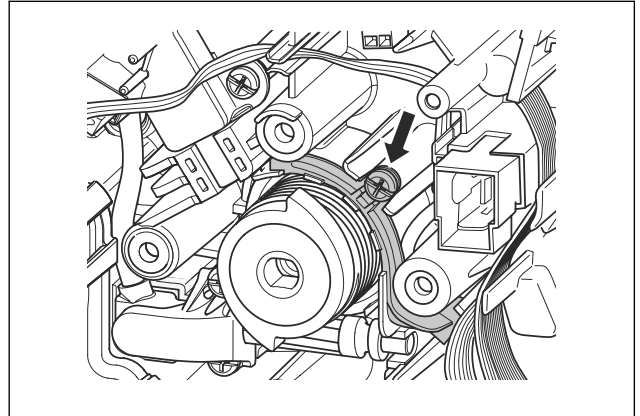

- Remove the screws to the control unit and the battery connector. Remove all control unit components.

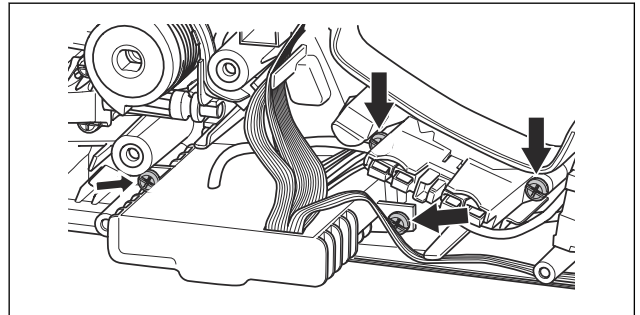

5.16.2 To assemble the control unit

- Assemble the control unit and battery connection in the crankcase.
- Assemble the cables in their correct positions. Make sure that no cables get caught between the crankcase halves.
- Attach the screws to the control unit (D) and the battery connection (E).

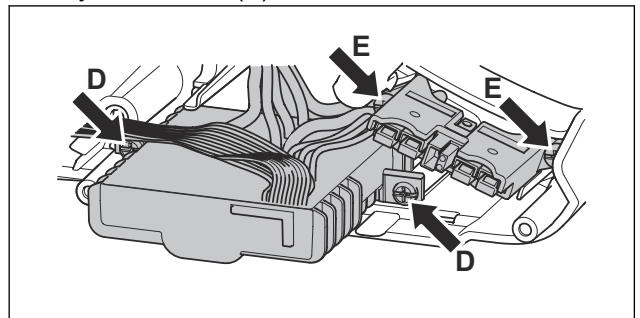

- Connect the connector to the keypad and put the connector together with the cables in the crankcase.

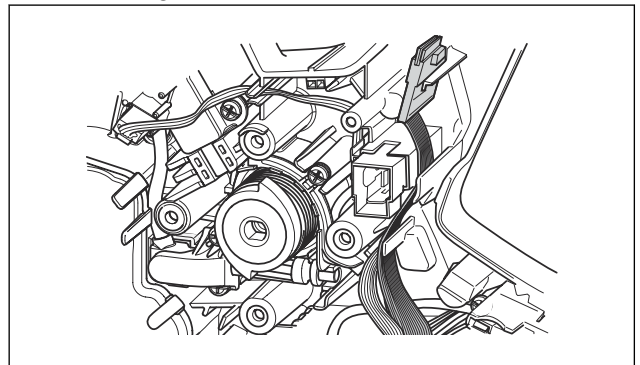

- Put the motor connection with cable and the chain brake sensor cables in the crankcase and assemble the cable holder.

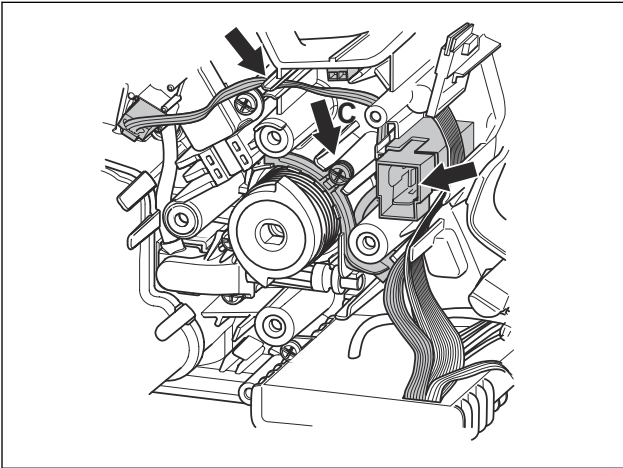

- Connect the connector to the chain brake sensor and attach it in its bracket.
- Connect in the connectors to the main switch and put the main switch into the crankcase.
- Attach the connectors to the motor.
- Make sure that the gray area in the illustration (A) is free from cables. This is the battery ejector (B).

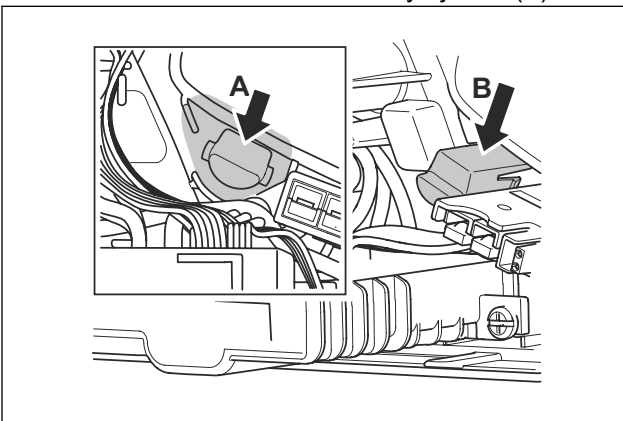

CAUTION: There is a risk that cables around the battery ejector get caught between other parts when the battery is attached.

- Assemble the product. See *To assemble the drive wheel cover and guide bar on page 9* and *To assemble the crankcase on page 9*.

5.17 Control unit S/N 20151600245-

5.17.1 To disassemble the control unit

Note: Look at how cables and other components are assembled before you disassemble. Be careful when

you assemble and make sure that the cables do not get caught between other parts.

- Disassemble the drive wheel cover, saw chain and guide bar. See *To assemble the drive wheel cover and guide bar on page 9*.
- Disassemble the crankcase. See *To assemble the crankcase on page 9*.
- Disassemble the motor. See *To assemble the motor on page 12*.
- Remove the screws to the main switch and battery terminal.

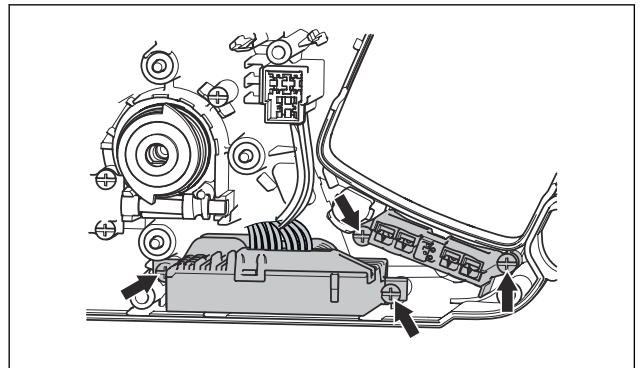

- Disconnect the wire bracket from the control unit. First holder (A) and then holder (B).

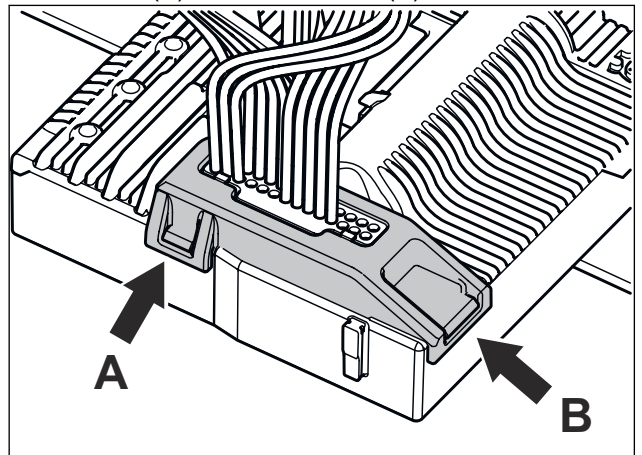

- Remove the motor connector from the holder. Remove the control unit and battery terminal.

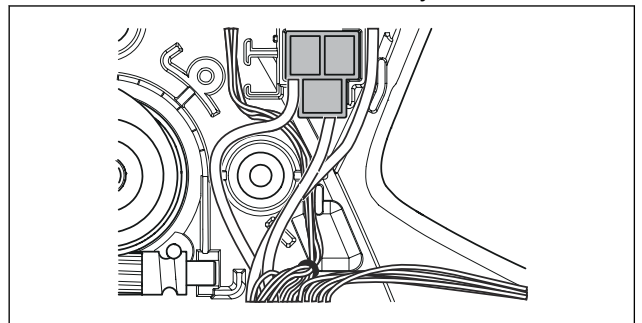

5.17.2 To assemble the control unit

1. Attach the wires to the control unit. Make sure that the sealing and bracket is correctly attached. First attach (A) and then (B).

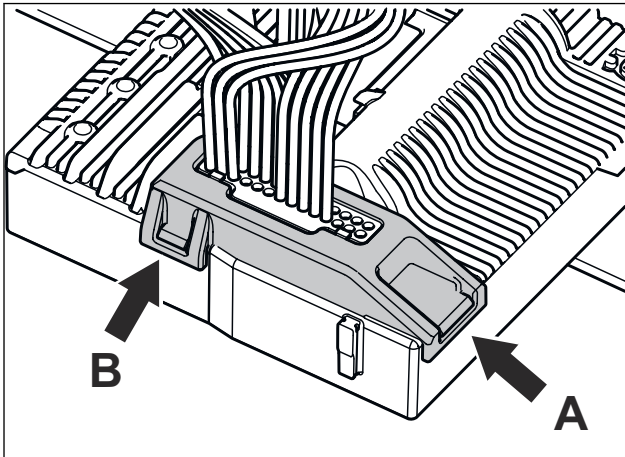

2. Attach the control unit and the battery terminal to the crankcase.

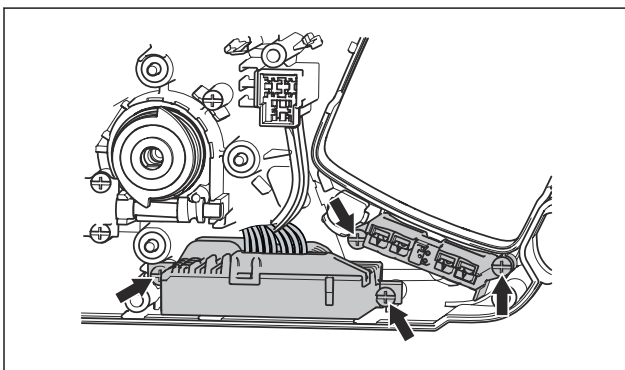

3. Put the motor connector in the holder. Assemble the cables as shown in the illustration.

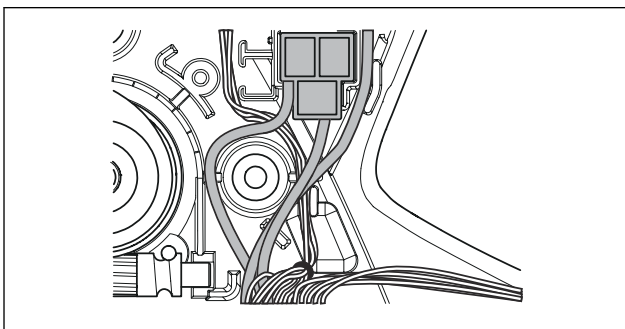

4. Make sure that the gray area in the illustration (A) is free from cables. This is the battery ejector (B).

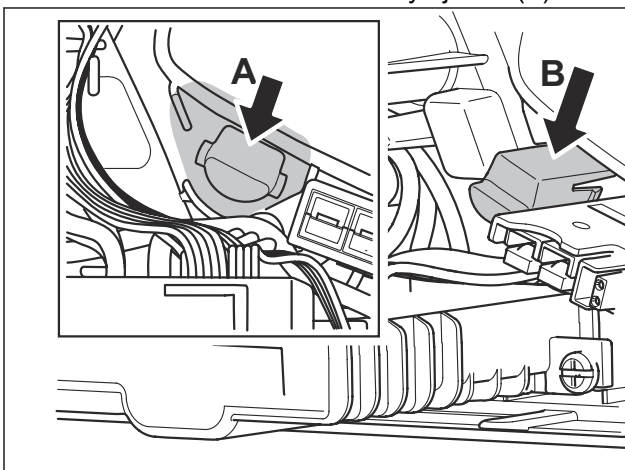

Note: There is a risk that cables around the battery ejector get caught between other parts when the battery is attached.

5. Assemble the product. See *To assemble the drive wheel cover and guide bar on page 9*, *To assemble the crankcase on page 9* and *To assemble the front hand guard on page 11*.

5.18 Replacing the keypad S/N -20151600245

5.18.1 To replace the keypad



CAUTION: Do not bend the keypad when you assemble.

1. Remove the drive wheel cover, saw chain and guide bar. See *To remove the drive wheel cover and guide bar on page 9*.
2. Disassemble the crankcase. See *To disassemble the crankcase on page 9*.
3. Carefully remove the keypad.
4. Disconnect the connection from the keypad.

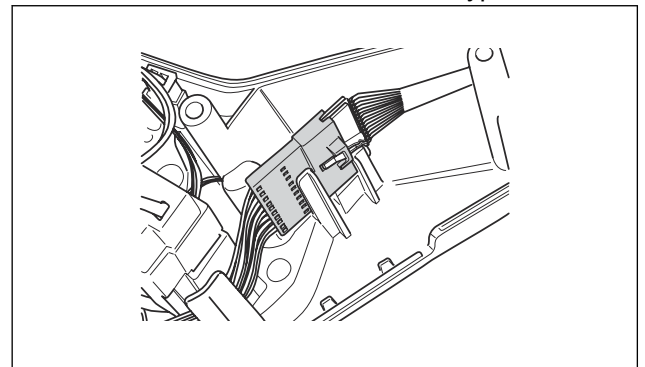

5. Clean the surface where the keypad is attached.
6. Make sure the temperature is not lower than 15°C or 59°F. The surface where you attach the keypad must not be more than $\pm 3^{\circ}\text{C}$ or 5°F from the air temperature. The temperature differs.
7. Remove the protective tape from the new keypad and press the keypad onto the surface. Press the keypad with 10 N/cm² for no less than 10 seconds.

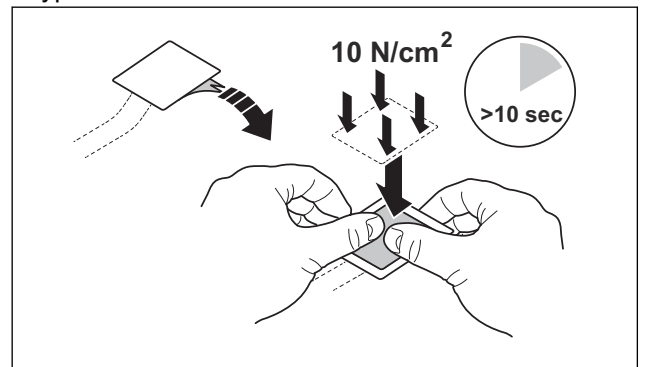

- Apply grease in the connector (A). Connect the connector and apply grease on all sides (B).

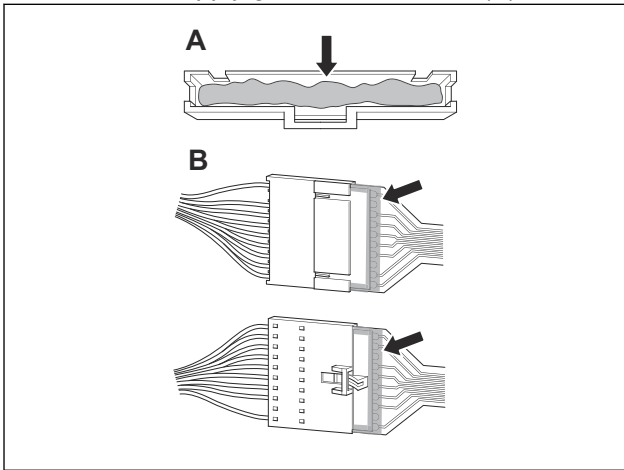

- Put the flat cable correctly in the crankcase.

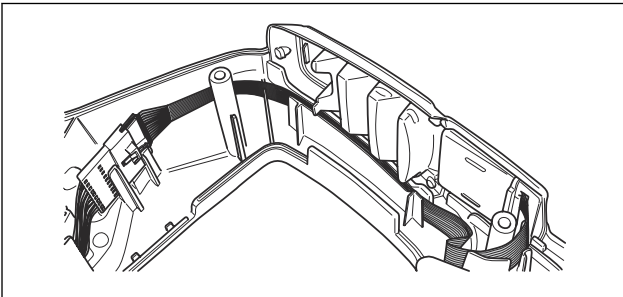

5.18.2 To disassemble the keypad

- Remove the drive wheel cover, saw chain and guide bar. See *To remove the drive wheel cover and guide bar on page 9*.
- Disassemble the crankcase. See *To disassemble the crankcase on page 9*.
- Disassemble the motor. See *To disassemble the motor on page 11*.
- Disconnect the wire bracket from the control unit. First disconnect (A) and then (B).

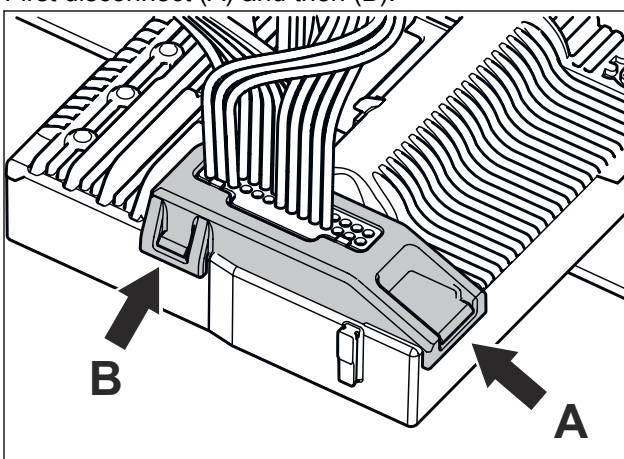

- Disconnect the hand guard connector (B).

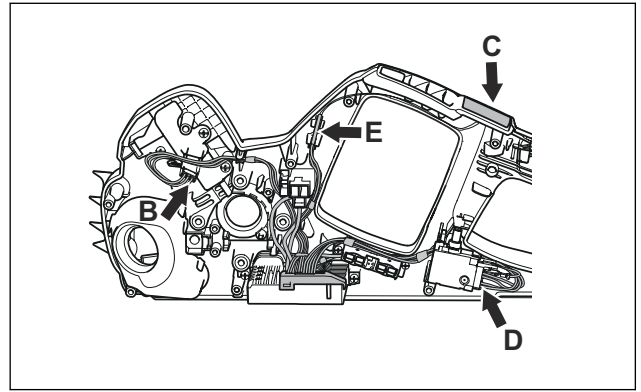

- Remove the keypad (C).
- Disconnect the main switch connection (D). See *Main switch S/N -20180600001 on page 13*.

5.19 Chain brake

5.19.1 To disassemble the chain brake



WARNING: Use protective goggles. The inner spring can eject out and cause injury.

- Remove the drive wheel cover, saw chain and guide bar. See *To remove the drive wheel cover and guide bar on page 9*.
- Disassemble the crankcase. See *To disassemble the crankcase on page 9*.
- Disassemble the motor. See *To disassemble the motor on page 11*.
- Disconnect the chain brake connector and put the cable to the side.
- Remove the screws and the chain brake cover.

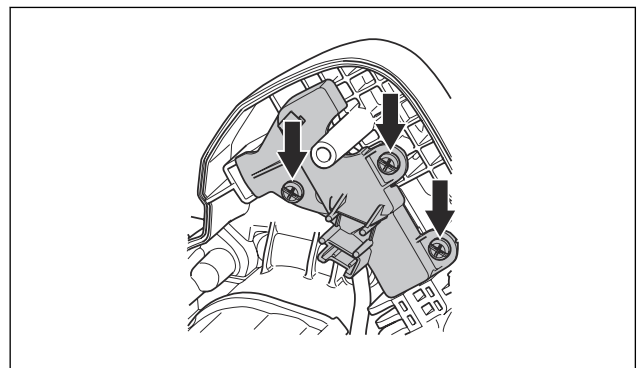

- Steer the large spring onto a screwdriver and remove the spring.

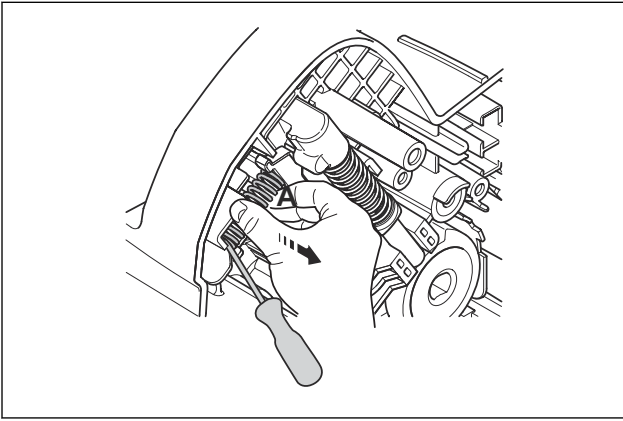

- Remove the spring and the shaft (B), and then the clamp (C).

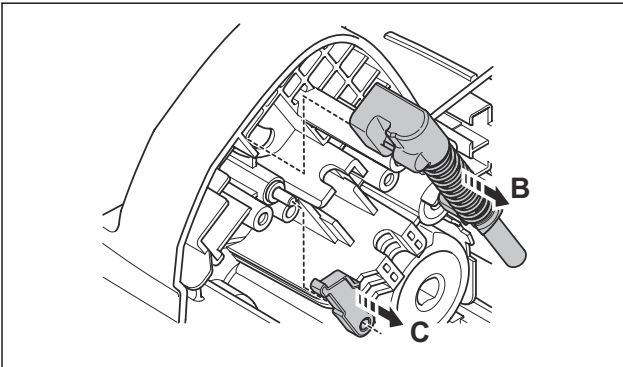

5.19.2 To assemble the chain brake



WARNING: Use protective goggles. Springs can eject and cause injury.

- Lubricate the parts.
- Put the spring and shaft (B) in the crankcase with the heel in its groove.

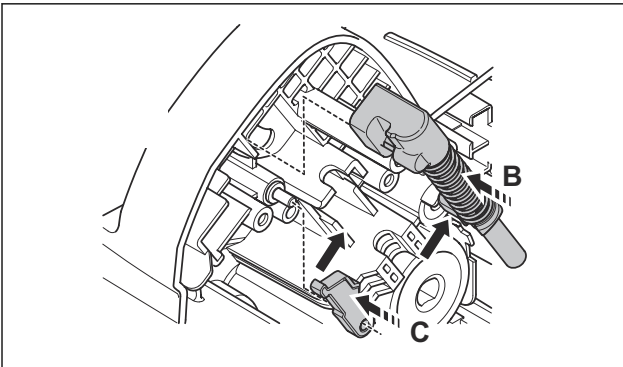

- Put the clamp (C) in the crankcase.

- Compress the large spring (A) and put it in its groove.

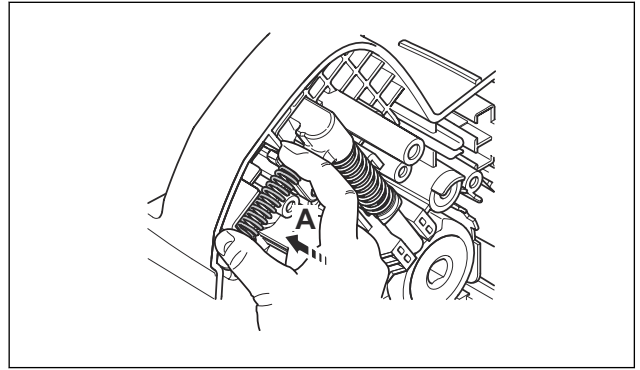

- Attach the chain brake cover.

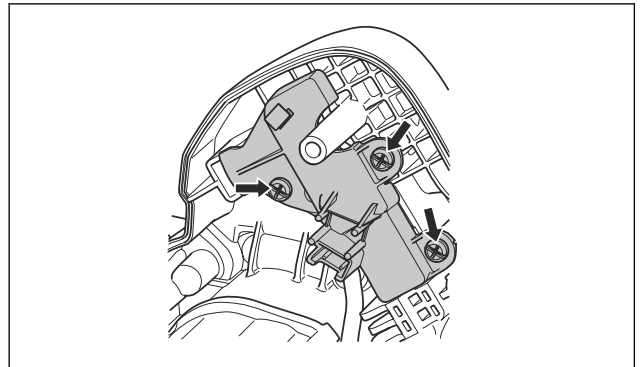

- Connect the sensor plug for the hand guard and put the cable in its holder.

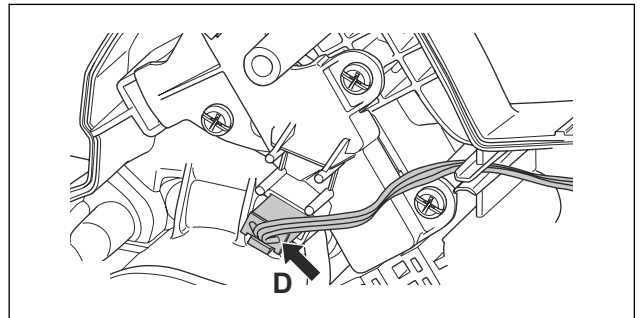

5.20 Chain brake sensor

5.20.1 To disassemble the chain brake sensor



WARNING: Use protective goggles. Springs can eject and cause injury.

- Remove the drive wheel cover, saw chain and guide bar. See *To remove the drive wheel cover and guide bar on page 9*.
- Disassemble the crankcase. See *To disassemble the crankcase on page 9*.

3. Disconnect the sensor plug on the chain brake.

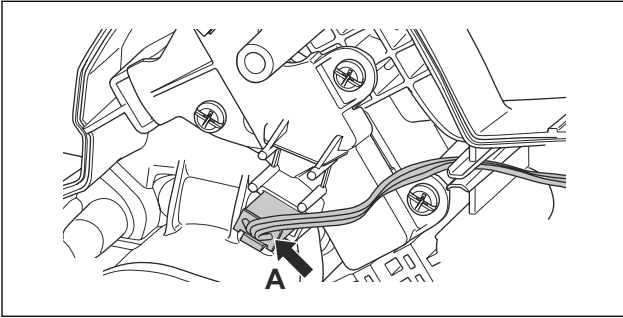

4. Disassemble the chain brake. See *To disassemble the chain brake on page 18*.
5. Remove the chain brake sensor.

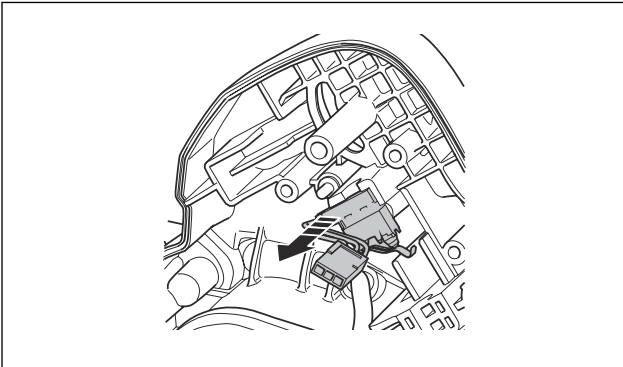

5.20.2 To assemble the chain brake sensor



WARNING: Use protective goggles. Springs can eject and cause injury.

1. Attach the sensor in the crankcase.

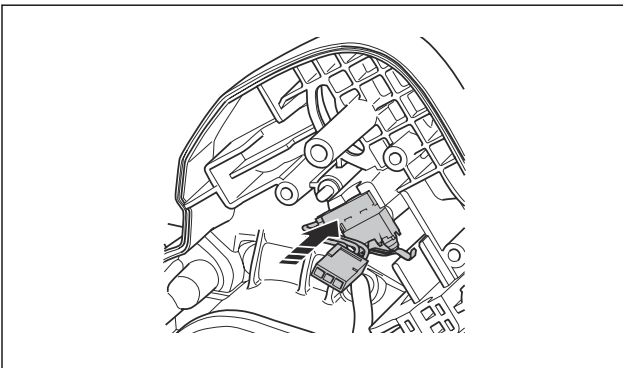

2. Assemble the chain brake. See *To assemble the chain brake on page 19*.
3. Connect the sensor plug on chain brake.

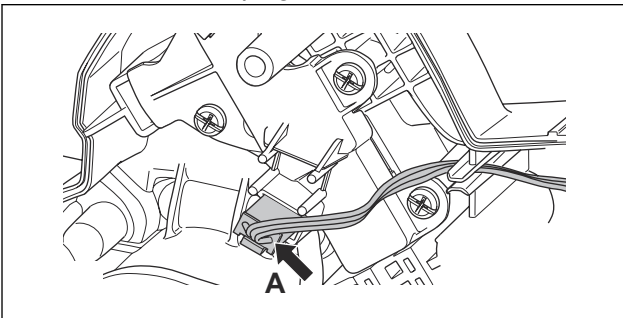

5.21 Oil pump

5.21.1 To disassemble the oil pump

1. Empty the chain oil tank.
2. Remove the drive wheel cover, saw chain and guide bar. See *To remove the drive wheel cover and guide bar on page 9*.
3. Disassemble the crankcase. See *To disassemble the crankcase on page 9*.
4. Remove the chain guide plate.
5. Disassemble the motor. See *To disassemble the motor on page 11*.
6. Remove the screws and the cover.

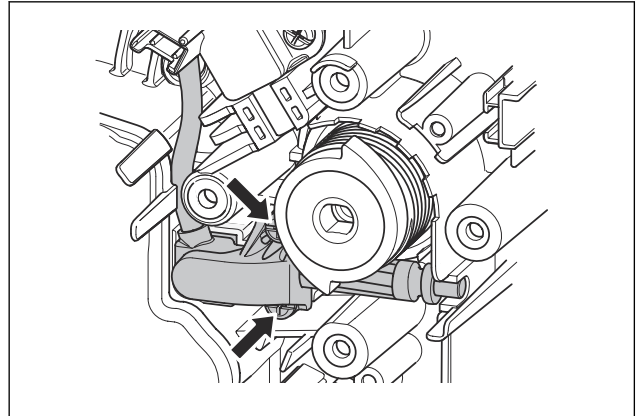

7. Remove the lubrication shaft and cylinder. Remove them from the rubber hose.

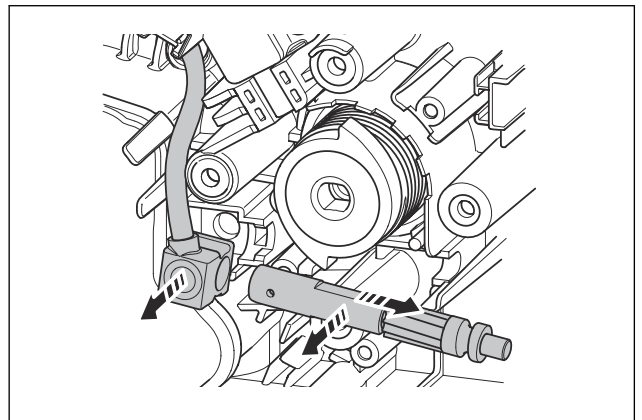

8. Remove the hose from the external side of the crankcase. Steer it through the hole and remove it at the same time.

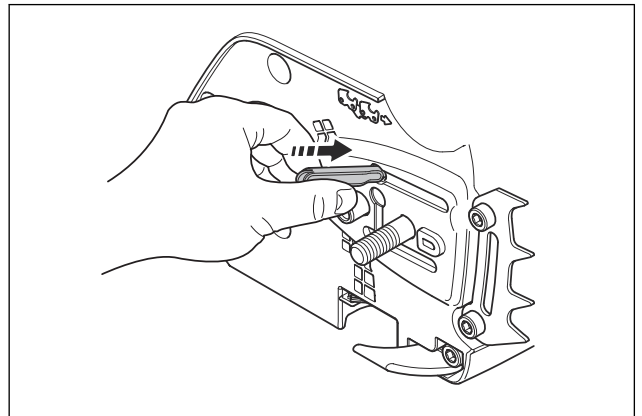

5.21.2 To assemble the oil pump

1. Lubricate the parts.
2. Steer the hose through the hole in the crankcase. Pull it out with your fingers or round nose pliers.

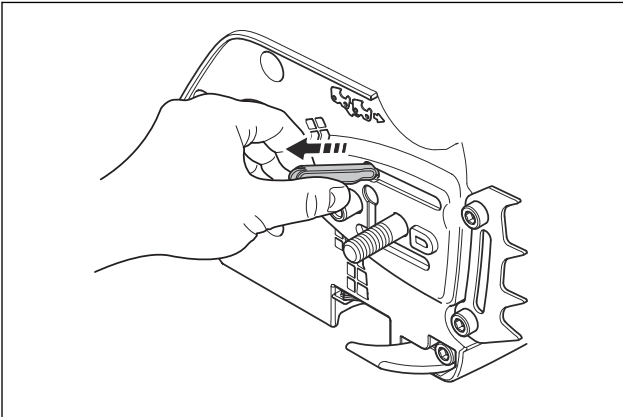

3. Put the hose in the groove on the external side of the crankcase.
4. Assemble the chain guide plate.
5. Put the cylinder and the lubrication shaft in the hole in the hose. Put the components in the crankcase.

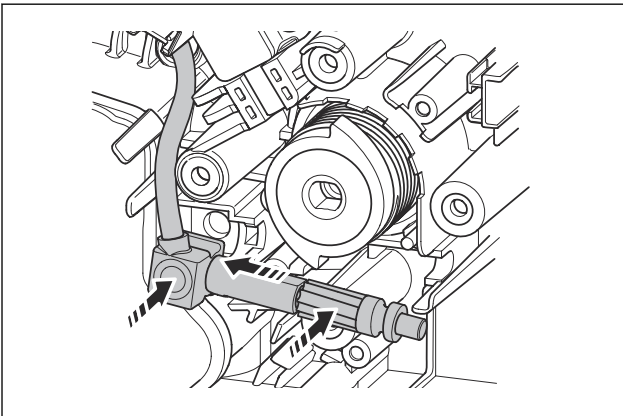

6. Assemble the oil pump cover.

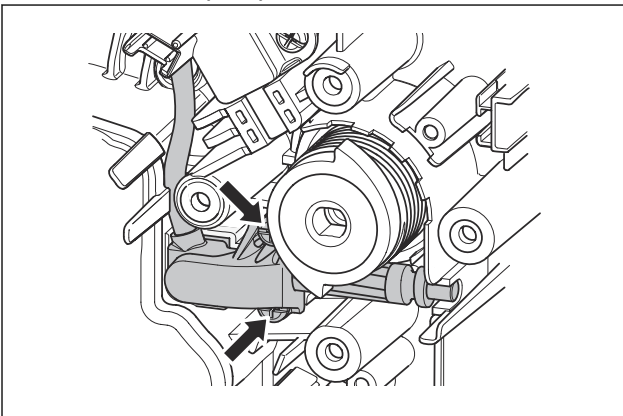

7. Assemble the motor. See *To assemble the motor on page 12*.
8. Assemble the crankcase. See *To assemble the crankcase on page 9*.
9. Fill with chain oil.

5.22 Chain tensioner 536Li XP/535i XP

5.22.1 To disassemble components of the chain tensioner 536Li XP/535i XP

1. Disassemble the drive wheel cover, saw chain and guide bar. *To remove the drive wheel cover and guide bar on page 9*
2. Remove the screws and remove the cover.

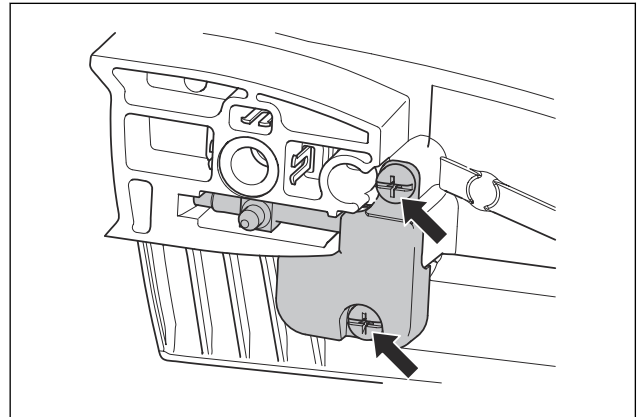

3. Remove the the chain tensioner and adjustment screw from the drive wheel cover.

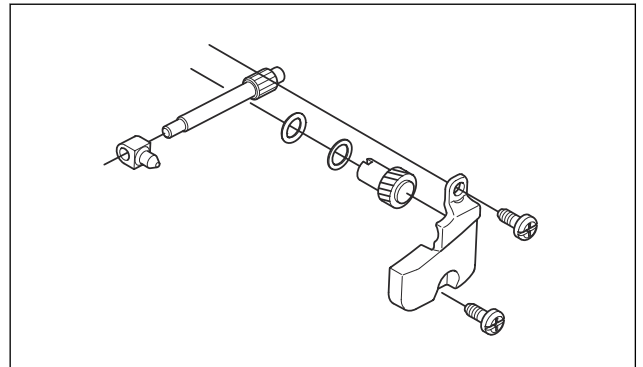

5.22.2 To assemble components of the chain tensioner 536Li XP/535i XP

1. Put the chain tensioner components in the drive wheel cover.

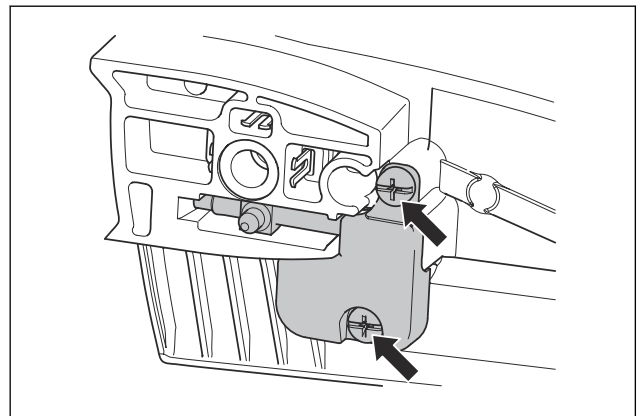

2. Attach the cover.
3. Assemble the drive wheel cover, saw chain and guide bar. See *To assemble the drive wheel cover and guide bar on page 9*

5.23 Chain tensioner 436Li/330i

5.23.1 To remove components of the chain tensioner 436Li/330i

1. Disassemble the drive wheel cover, saw chain and guide bar. *To remove the drive wheel cover and guide bar on page 9*
2. Remove the screws and remove the wear guard, cap and the chain tensioner components.

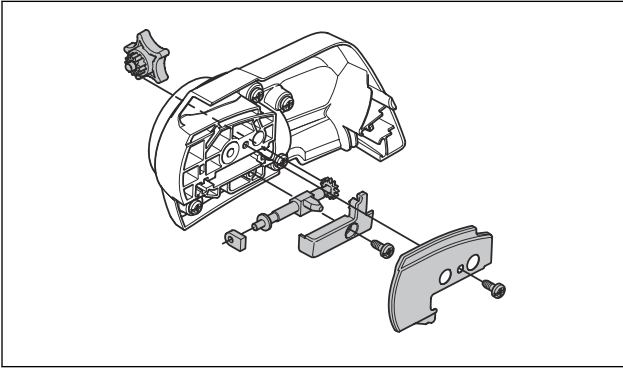

5.23.2 To attach components the chain tensioner 436Li/330i

1. Put the chain tensioner components in the drive wheel cover.

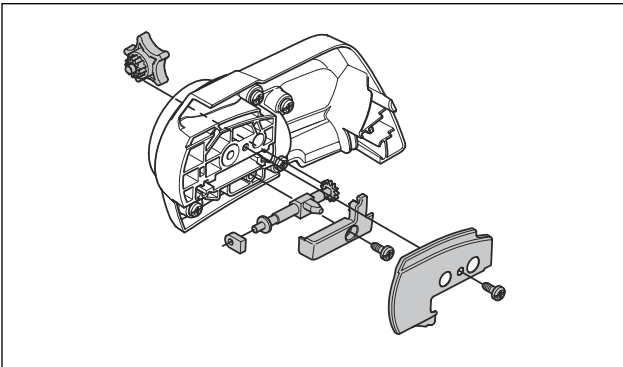

2. Attach the wear guard and cap.
3. Assemble the drive wheel cover, saw chain and guide bar. See *To assemble the drive wheel cover and guide bar on page 9*

6 Troubleshooting

6.1 To connect the common service tool

1. Connect the adapter cable for the common service tool to the battery and the battery connector on the product. Connect cable (A) to the common service tool to do troubleshooting of the product. Connect cable (B) to the common service tool to do troubleshooting of the battery.

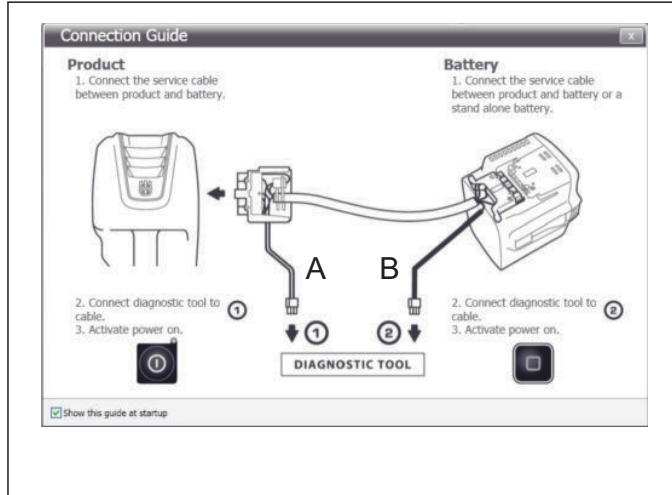

Note: Refer to the manual for the common service tool for instructions and obey the instructions.

2. Do troubleshooting as given in the common service tool instructions.

6.2 To do troubleshooting of the common service tool

If there is no signal to the common service tool when it is connected to the product, do the procedure that follows.

1. Make sure that the connectors on the battery and on the product are clean and not damaged. Replace the battery or control unit on the product if there is damage.
2. Make sure that the cable to the common service tool is clean and not damaged. Replace the cable if there is damage.
3. Restart the computer.
4. Install the software again.

6.3 Troubleshooting of the product

Symptom	Possible causes	Recommended step
The product does not start. No LEDs come on when you press the on/off button.	Defective battery.	Press the on/off button to do a check of the battery. A minimum of 1 green LED must come on.
	Defective plug between battery and product.	Make sure that the power connectors between the battery and the product are not dirty or damaged.
	Defective connection in keypad connector.	Make sure that the keypad connector is correctly assembled, dry, not damaged and that there is no corrosion.
	Broken keypad.	Replace keypad.
	Cables between control unit and keypad/main switch are damaged.	Repair/replace the cables if you can see damages.
	Short circuit in control unit.	Replace control unit.
Electrical motor makes sudden movement when you push the power trigger, then stops.	Short circuit in control unit.	Replace the control unit.
Product stops when you apply work load.	Defective connection in keypad connector.	Make sure that the power connectors between battery and product are clean and not damaged.
Keypad lights flash.	Defective connection in keypad connector.	Make sure that the keypad connector is correctly assembled, dry, not damaged and that there is no corrosion.
	Short circuit in keypad.	Replace keypad.
Changing motor speed.	Defective connection in main switch signal connector.	Make sure that the keypad connector is correctly assembled, dry, not damaged and that there is no corrosion.
	Damaged or worn main switch.	Replace keypad.

Symptom	Possible causes	Recommended step
A warning sign on keypad flashes continuously.	Temperature too high.	Wait for the product to become cool (max. 5 min.).
	Temperature of control unit or battery too low.	Make sure that the product and the battery is not colder than -10° C.
	Front handle safety switch is caught in engaged position.	Disassemble front handle and remove dirt.
A warning sign on the keypad flashes after start. The product then stops.	Power trigger is pushed during start.	Do not push the power trigger when you start the product.
	Water in main switch signal connector.	Disassemble and dry the stop signal connector and then assemble it.
	Short circuit in keypad.	Replace the keypad.
	Short circuit in main switch.	Replace the main switch.
A warning sign on the keypad flashes after start. The product hangs up with the green led on.	The signal between battery and product is defective.	Make sure that the power connectors between the battery and the product are not dirty or damaged.
		Make sure that the small cables between connector and the control unit are not loose or damaged.
Product works but there is no indication light on the keypad.	Defective connection in keypad connector.	Do a check of the keypad function in battery diagnostic tool. Make sure that the keypad connector is correctly assembled, dry, not damaged and that there is no corrosion.
	Broken keypad.	Replace the keypad.
Product starts immediately when battery is added, without pressing the keypad.	Short circuit in keypad.	Replace the keypad.
A warning sign on keypad shows a red light.	Permanent error codes prevent the product from running.	Erase error codes in diagnostic tool.
	Broken control unit.	Replace control unit.
Product shows red light after installing a new control unit.	Spare part comes without software.	Use diagnostic tool to install software.

6.4 Troubleshooting of the battery and battery charger

Symptom	Possible causes	Recommended step
No LEDs flash on the battery when you press the start button.	Defective battery.	Replace the battery.
A warning sign shows a constant red light on the battery when the start button is pressed.	Defective battery.	Replace the battery.
A warning sign flashes red on the battery when the start button is pressed.	Temperature is too high.	Wait until the battery has become cool (or insert in charger to let it become cool faster).
	Low voltage.	Charge the battery.
	Temperature too low.	Make sure that the battery temperature is higher than -10° C.
	Defective battery.	Replace the battery.
The battery shows less than 100% after a full charge. (Usually 96-97%).	Some ratio of the charge may be used up by the electronics.	None. The charger restarts when the charge level is less than 95%.
Charger does not start and no LEDs come on when the battery is attached.	Defective connection between charger and battery.	Make sure that the power plugs between the charger and the battery are clean and not damaged.
	Defective battery.	Check battery start.
	Defective charger.	Disconnect charger from the mains outlet for a minimum of 1 minute and then connect to the mains outlet again. Make sure that the fan starts and that the green LED comes on for approximately 3 seconds. If not, replace the charger.
A red warning sign flashes on the charger when the battery is attached.	Defective connection between charger and battery.	Make sure the power plugs between the charger and battery are not dirty or damaged.
	Battery temperature too high.	Let the battery become cool in the charger (1-5 min).
	Ambient temperature too low.	Make sure that the ambient temperature is above 5°C.
	Battery temperature too low.	Make sure that the battery temperature is higher than 5°C.
	Defective battery.	Make sure that the battery is in order by pressing the battery start button. A minimum of 1 green LED must come on. If not, replace the battery.
	Defective charger.	Disconnect charger from the mains outlet for a minimum of 1 minute and then connect to the mains outlet again. Make sure that the fan starts and that the green LED comes on for approximately 3 seconds. If not, replace the charger.
Solid red warning sign on charger when put into mains outlet.	Defective charger.	Replace the charger.
Solid red warning sign on charger during charging.	Defective charger.	Replace the charger.

Symptom	Possible causes	Recommended step
A green lamp on the charger comes on for approximately 5-10 seconds when the battery is attached. After that a red warning sign flashes on the charger. This sequence then occurs again.	Defective Battery.	Put the battery in a QC330 charger. If the same problem occurs, replace the battery.
	Defective charger.	Put a battery in the charger. If the same problem occurs, replace the charger.

6.5 Troubleshooting appendix

6.5.1 Power connectors

Make sure connectors are clean and that metal surfaces are not damaged.

Note: The connection tabs on the power connectors have the same construction on product, battery and charger. The colors can be different.

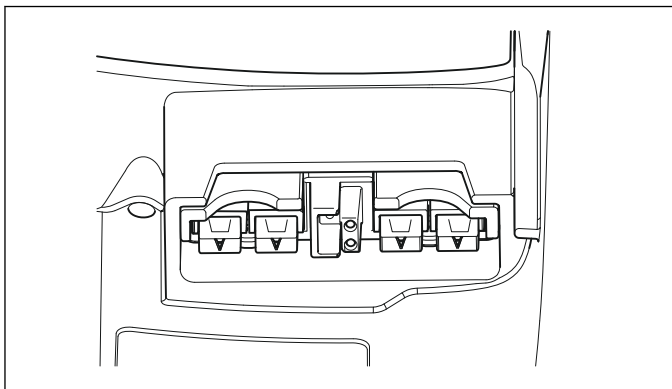

6.5.2 Keypad connector

Make sure that the 2 connector parts are fully attached. Look for damaged or loose cables.

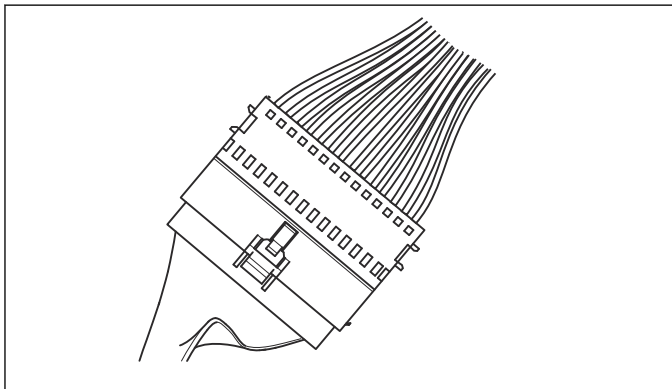

6.5.3 Signal connector for the main switch

For products with: S/N -2018060001

Make sure the white female connector is fully attached to the main switch. Look for damaged or loose cables.

Also look for signs of water, corrosion or short circuit on the connector and pins when disassembled.

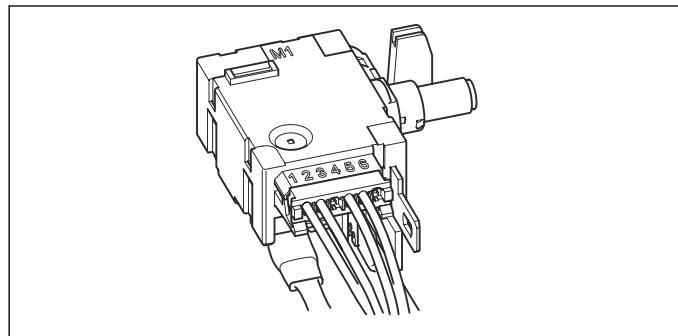

6.5.4 Signal connector for the main switch

For products with: S/N -2018060001

Apply grease between the pins 1 and 2 and between the pins 3 and 4, inside as well as outside.

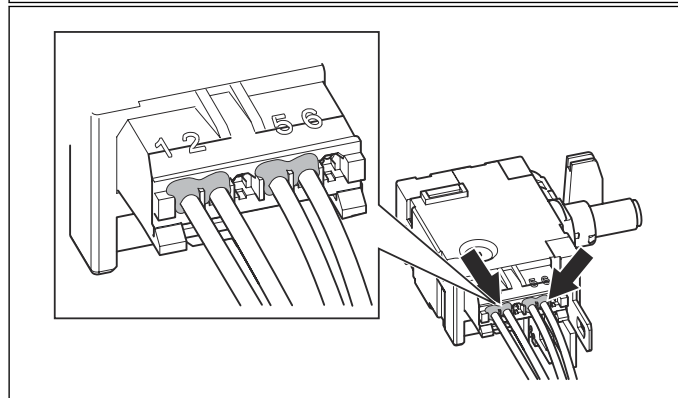
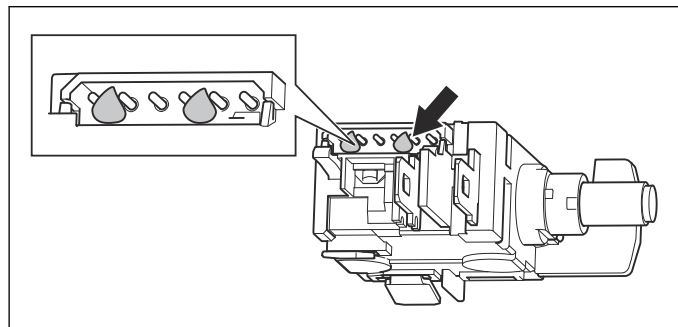

6.5.5 Motor connector

Make sure the motor connector is assembled with a tight fit on the control unit.

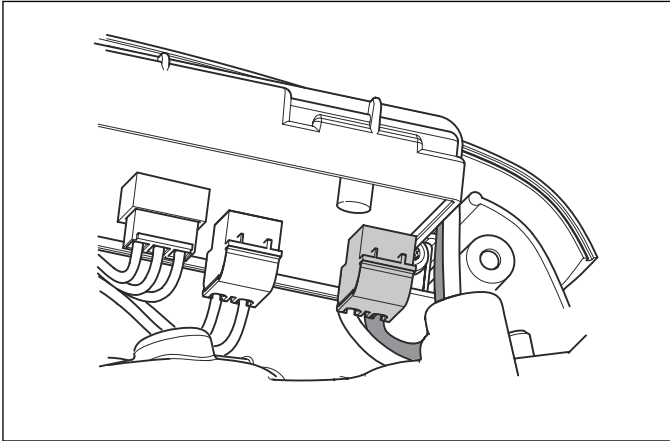

6.5.6 Motor connector

Make sure that the motor connector is attached tightly to the control unit.

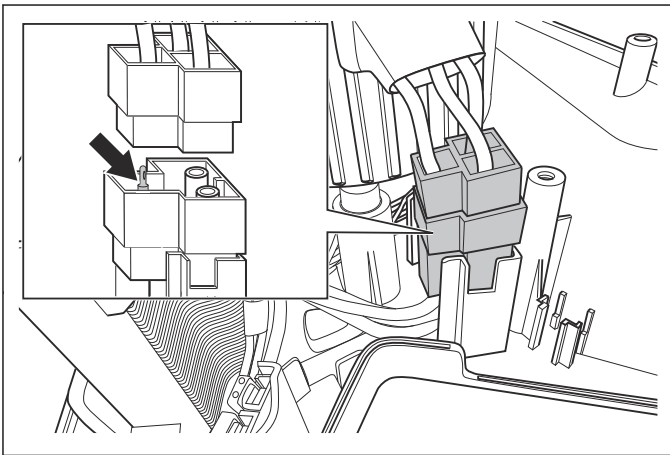

6.5.7 Communication cables

Make sure the 3 small communication cables are not loose or damaged.

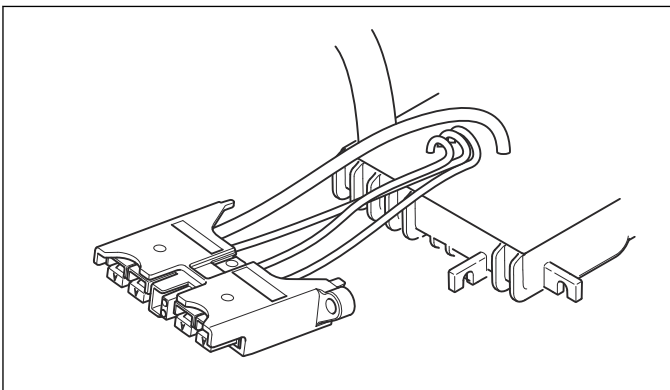

6.5.8 Communication cables

Make sure the three small communication cables are not loose or damaged.

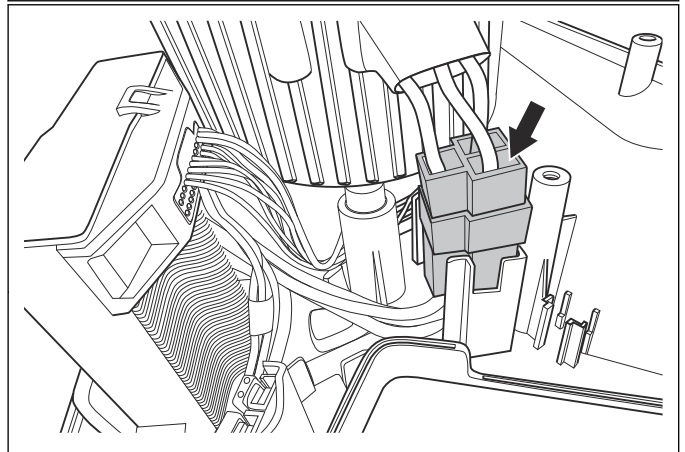
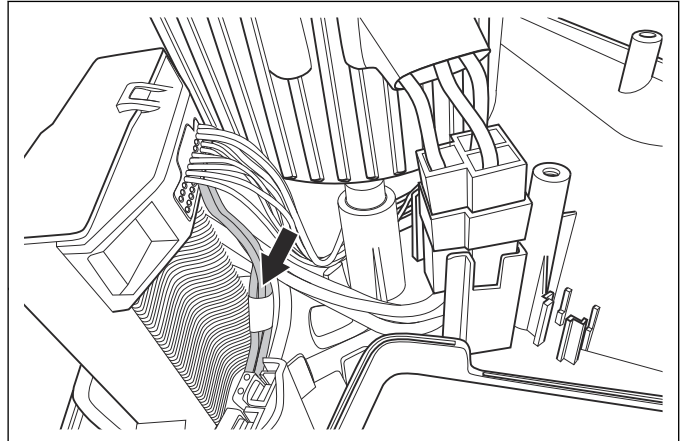

6.5.9 The wiring cable

Make sure the 26-pin wiring cable is properly assembled, dry and not damaged.

6.5.10 To disassemble the battery connector



CAUTION: The pin in the connector of the communication cable is loose and can fall out.

1. Remove the battery connector.
2. Push out the pins with a screwdriver.

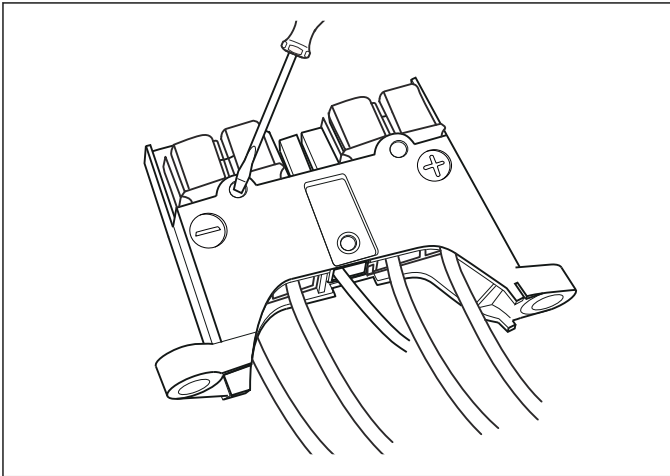
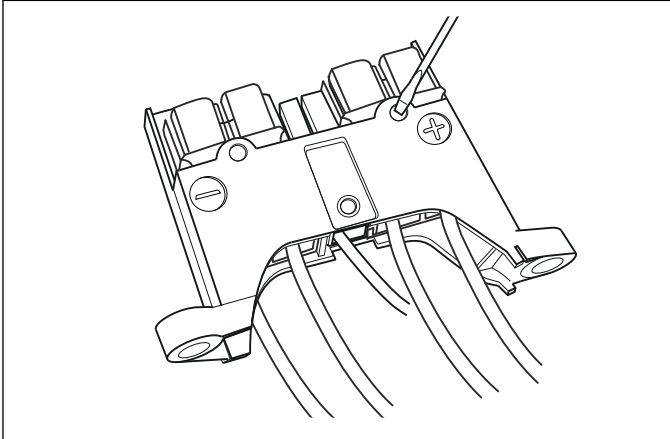

3. Pull out the wires and connectors to the positive and negative terminals.

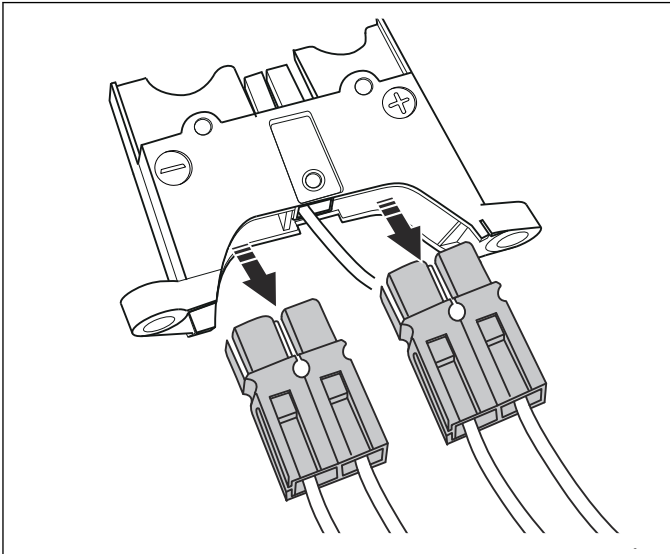

4. Lift the plastic fastener and pull out the communication cable, if installed.

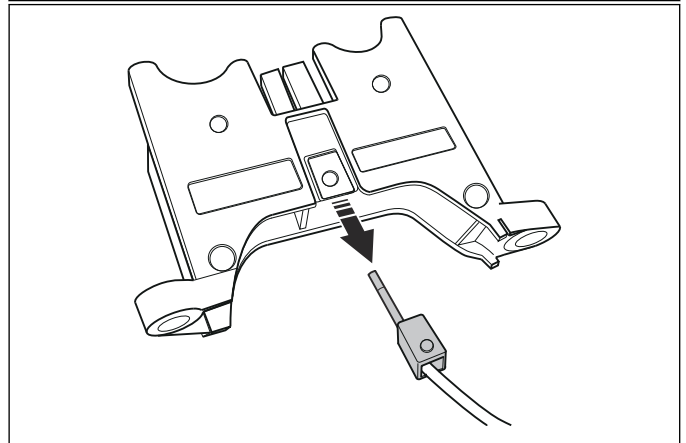
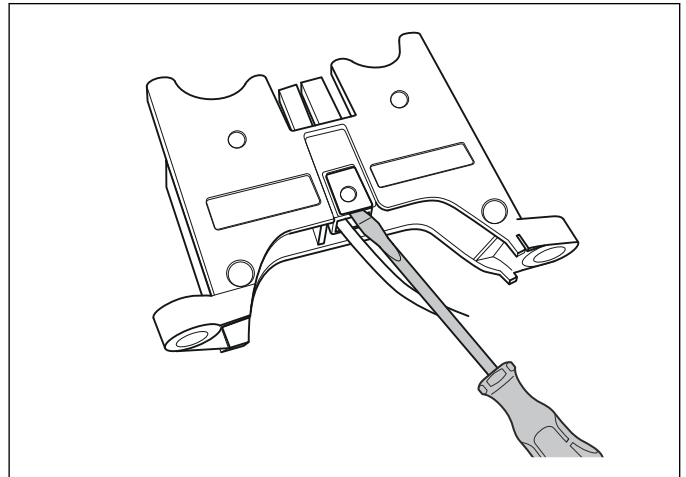

6.5.11 To assemble the battery connector



CAUTION: The pin in the connector of the wire is loose and can fall out.

1. Push the communication cable connector into the plastic housing, if the battery connector has a communication cable.

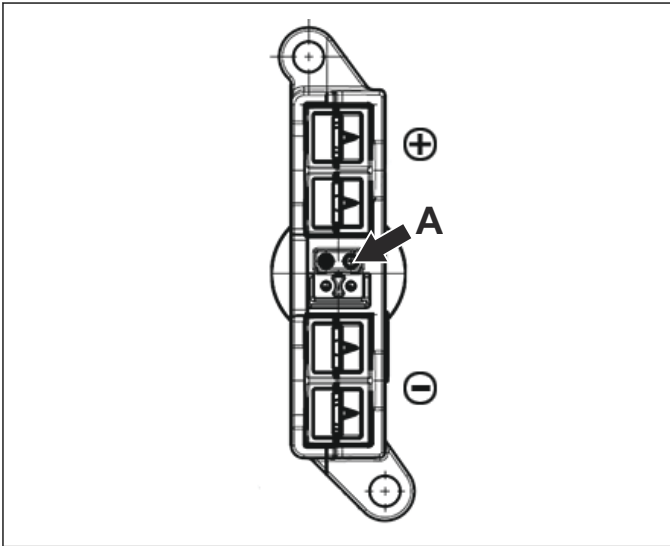
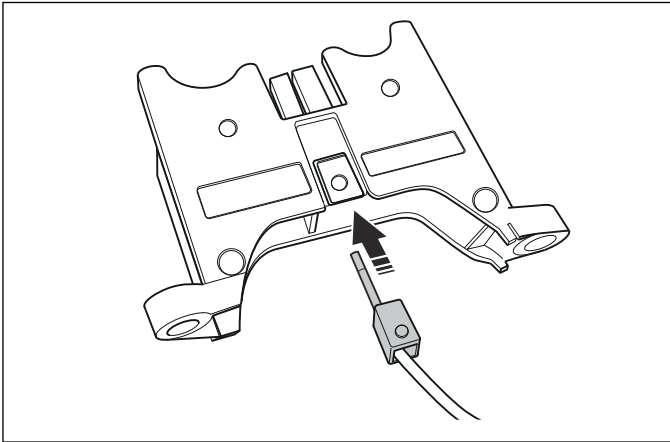

CAUTION: Make sure the pin in the communication cable connector is in the correct position (A). The product cannot send information to the common service tool, if the pin is missing or in the incorrect position.

2. Put the battery connector with the red wire into the positive side of the plastic housing. Align the holes for the pins.

3. Put the battery connector with the black wire into the negative side of the plastic housing. Align the holes for the pins.

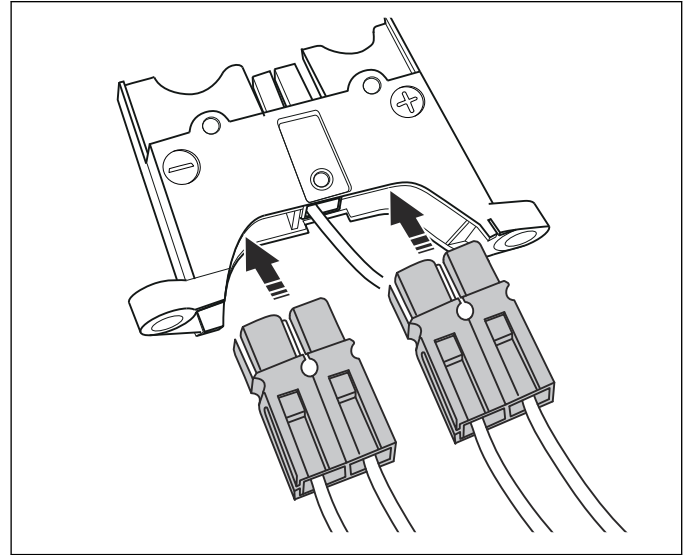

4. Push the pins into the holes through the housing and the connectors.

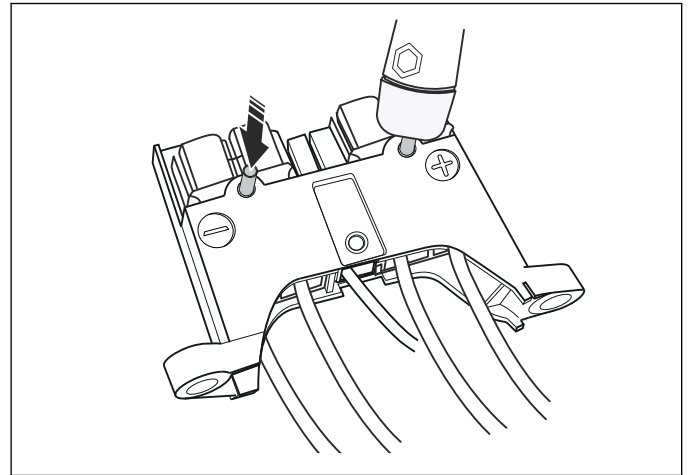

CAUTION: Make sure that the holes in the connections align with the holes in the housing before you push in the pins.



www.husqvarna.com

1155399-26

2018-12-07